

HOW TO REMOVE WW2 JEEP SWAGED BRAKE DRUM STUDS

by: John GIBBINS [artificer on G503] Updated 17th March 2015
email contact: artificer[at]engineer.com

This subject always comes up as an ongoing issue, so valid instructions are in order/needed.

Although the TM says otherwise [especially for later model Jeeps that have drums mounted externally] in my experience JEEP brake drums that are directly attached to the 'hub' internally via swaged wheel studs do not come out easily by hammering or pressing out the wheels studs.

Trying to use this TM method generally ruins the hub by removing securing material from same. Then the new drum & new studs can't be properly secured to the hub without having to do what is done in Fig. 2. & that is an unacceptable repair.

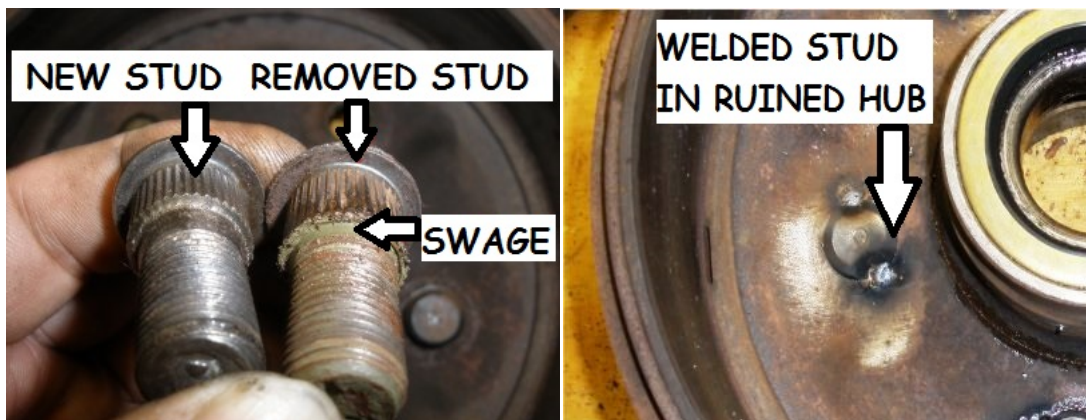

Figure 1 & Figure 2

Figure 3 indicates how one should do things properly & do them once.

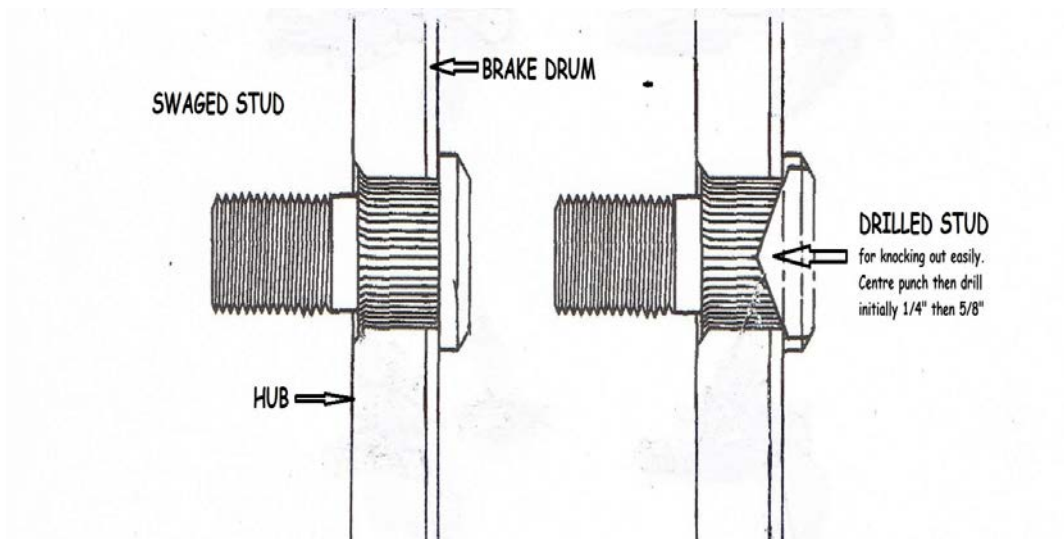

Figure 3