

Notice to Students

Use the Ordnance Training Division website,
<http://www.cascom.army.mil/ordnance/>,
to submit your questions, comments, and suggestions
regarding Ordnance and Missile & Munitions
subcourse content.

If you have access to a computer with Internet capability and can receive e-mail, we recommend that you use this means to communicate with our subject matter experts. Even if you're not able to receive e-mail, we encourage you to submit content inquiries electronically. Simply include a commercial or DSN phone number and/or address on the form provided. Also, be sure to check the Frequently Asked Questions file at the site before posting your inquiry.

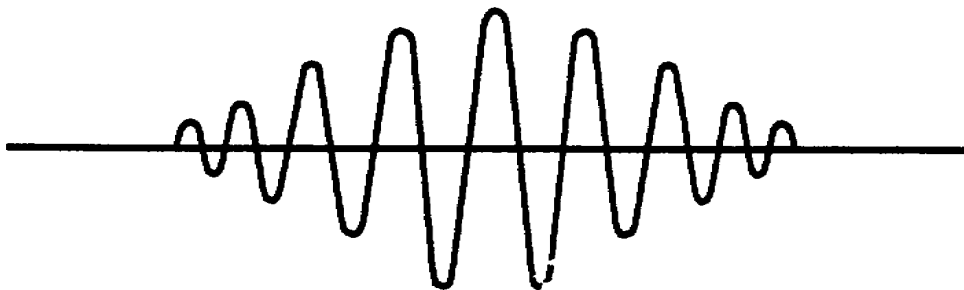

US ARMY LIGHT WHEEL VEHICLE MECHANIC
MOS 63B SKILL LEVEL 3 COURSE

WHEELED VEHICLE BRAKING SYSTEMS

SUBCOURSE NO. OD1008

US Army Ordnance Center and School

Five Credit Hours

GENERAL

The Wheeled Vehicle Braking Systems subcourse, part of the Light Wheel Vehicle Mechanic MOS 63B Skill Level 3 course, is designed to teach the knowledge necessary to develop the skills for servicing and maintaining braking systems. Information is provided on the principles and operation of mechanical, hydraulic, air-hydraulic, air, and electric brake systems. Information is also provided on the inspection of these systems. This subcourse is presented in three lessons, each lesson corresponding to a terminal objective as indicated below.

Lesson 1: FUNDAMENTALS OF WHEELED VEHICLE BRAKING SYSTEMS

TASK: Describe the principles of automotive brake systems and the construction and operation of mechanical and hydraulic brake systems.

CONDITIONS: Given information on the principles of braking, and the construction and operation of internal and external drum brakes, disk brakes, mechanical and hydraulic brake systems, and parking brakes.

STANDARDS: Answer 70 percent of the multiple-choice test items covering fundamentals of wheeled vehicle braking systems.

Lesson 2: AIR-HYDRAULIC BRAKE SYSTEMS

TASK: Describe the principles, construction, and operation of air-hydraulic brake systems.

CONDITIONS: Given information on the purpose, components, operation, and inspection of air-hydraulic brake systems.

STANDARDS: Answer 70 percent of the multiple-choice test items covering fundamentals of air-hydraulic brake systems.

Lesson 3: AIR-BRAKE SYSTEMS

TASK: Describe the principles, construction, and operation of straight air-brake systems.

CONDITIONS: Given information on the components and operation of straight air-brake systems.

STANDARDS: Answer 70 percent of the multiple-choice test items covering fundamentals of air-brake systems.

TABLE OF CONTENTS

Section	Page
TITLE PAGE.....	i
TABLE OF CONTENTS.....	iii
INTRODUCTION TO WHEELED VEHICLE BRAKING SYSTEMS.....	vi
Lesson 1: FUNDAMENTALS OF WHEELED VEHICLE BRAKING SYSTEMS	
Learning Event 1: Describe the Principles of Braking and Braking Systems.....	1
Learning Event 2: Describe the Construction and Operation of Hydraulic Brake Systems.....	24
Learning Event 3: Describe Inspection Procedures for Hydraulic Brake Systems.....	30
Practice Exercise.....	35
Answers to Practice Exercise.....	36
Lesson 2: AIR-HYDRAULIC BRAKE SYSTEMS	
Learning Event 1: Describe the Components of the Air-Hydraulic Brake System.....	37
Learning Event 2: Describe the Operation of the Air-Hydraulic Brake System.....	48
Learning Event 3: Describe Inspection Procedures for the Air-Hydraulic Brake System.....	56
Practice Exercise.....	63
Answers to Practice Exercise.....	64

Section	Page
Lesson 3: AIR-BRAKE SYSTEMS	
Learning Event 1: Describe the Components of the Straight Air-Brake System.....	65
Learning Event 2: Describe the Operation of the Straight Air-Brake System.....	73
Learning Event 3: Describe Inspection Procedures for the Straight Air-Brake System.....	80
Practice Exercise.....	87
Answers to Practice Exercise.....	88

***** IMPORTANT NOTICE *****

THE PASSING SCORE FOR ALL ACCP MATERIAL IS NOW 70%.

PLEASE DISREGARD ALL REFERENCES TO THE 75% REQUIREMENT.

THIS PAGE INTENTIONALLY LEFT BLANK

INTRODUCTION TO WHEELED VEHICLE BRAKING SYSTEMS

Up to this point, each one of our subcourses has covered all the things that were needed to make a vehicle go forward and backward. We now know that an operator has controls to make this equipment go fast or slow; to the right or left; through mud, snow, sand; and on level roads. But what does the operator do if a child runs out in front of this moving vehicle, or when traveling on a road a point is reached where a bridge is washed out? The answer is that the operator must have one or more controls that will bring the vehicle to a stop rapidly and with a small amount of effort. The braking system provides these controls.

Braking is the use of friction to slow a vehicle, bring it to a halt, or hold it in a standing position. A brake is a device that is secured to the vehicle axle housings, which do not rotate, and is used to slow down or hold the wheels, which do rotate. When the rotating parts are brought in contact with the nonrotating parts, the friction caused by the rubbing creates the braking action.

All vehicles must be built so they meet the minimum braking requirements. For many years it has been a set standard that a braking system must be able to stop a vehicle traveling 20 miles per hour (MPH) within 30 feet. You must remember, however, this does not mean the vehicle will always stop in 30 feet. It does mean that if the tires could get enough traction on the road, the brakes must hold well enough to stop it in that distance. To get an idea of how much power is involved in braking systems, imagine a 10,000-pound truck traveling 50 MPH being braked at the rate discussed above. The energy required to do the braking would be equivalent to 500 horsepower (HP). This is much more than the vehicle engine could ever produce. Most of the braking systems on modern passenger cars can handle about eight times the power developed by the engine.

This subcourse is designed to provide you with a knowledge of how braking system components operate.

LESSON 1
FUNDAMENTALS OF WHEELED VEHICLE BRAKING SYSTEMS

TASK

Describe the principles of automotive brake systems and the construction and operation of mechanical and hydraulic brake systems.

CONDITIONS

Given information on the principles of braking and the construction and operation of internal and external drum brakes, disk brakes, mechanical and hydraulic brake systems, and parking brakes.

STANDARDS

Answer 70 percent of the multiple-choice test items covering fundamentals of wheeled vehicle braking systems.

REFERENCES

TM 9-8000

Learning Event 1:

DESCRIBE THE PRINCIPLES OF BRAKING AND BRAKING SYSTEMS

INTRODUCTION

Braking action on wheeled vehicles is the use of a controlled force to hold, stop, or reduce the speed of a vehicle. Many factors must be considered when designing the braking system for an automotive item. The vehicle weight, size of tires, and type of suspension are but a few that influence the design of a system.

Lesson 1/Learning Event 1

The power needed to brake a vehicle is equal to that needed to make it go. However, for safety reasons, brakes must be able to stop the car in a very short distance. As an example, a passenger car equipped with an 80-HP engine can normally accelerate from a standstill to 60 MPH in about 36 seconds. On the other hand, the brakes must be able to decelerate the vehicle from 60 MPH to a stop in 4 1/2 seconds. You can therefore see the braking force is about eight times greater than the power developed by the engine.

Each part in the braking system must operate with a very positive action to accomplish this tremendous braking effort. The job of a wheeled vehicle mechanic is to maintain the braking components in a state of repair that ensures serviceable brakes when needed. For you to keep brake system components in a working shape, you must understand how the system works. In this lesson, we will discuss the principles of operation for components contained in various types of braking systems.

Braking action is the use of a controlled force to slow the speed of or stop a moving object, in this case a vehicle. It is necessary to know what friction is to understand braking action.

Friction is the resistance to movement between two surfaces or objects that are touching each other. An example of friction is the force which tries to stop your hand as you apply pressure and slide it across a table or desk. This means that by forcing the surface of an object that is not moving (stationary) against a moving object's surface, the resistance to movement or the rubbing action between the two surfaces of the objects will slow down the moving surface. Automotive vehicles are braked in this manner.

PRINCIPLES OF BRAKING

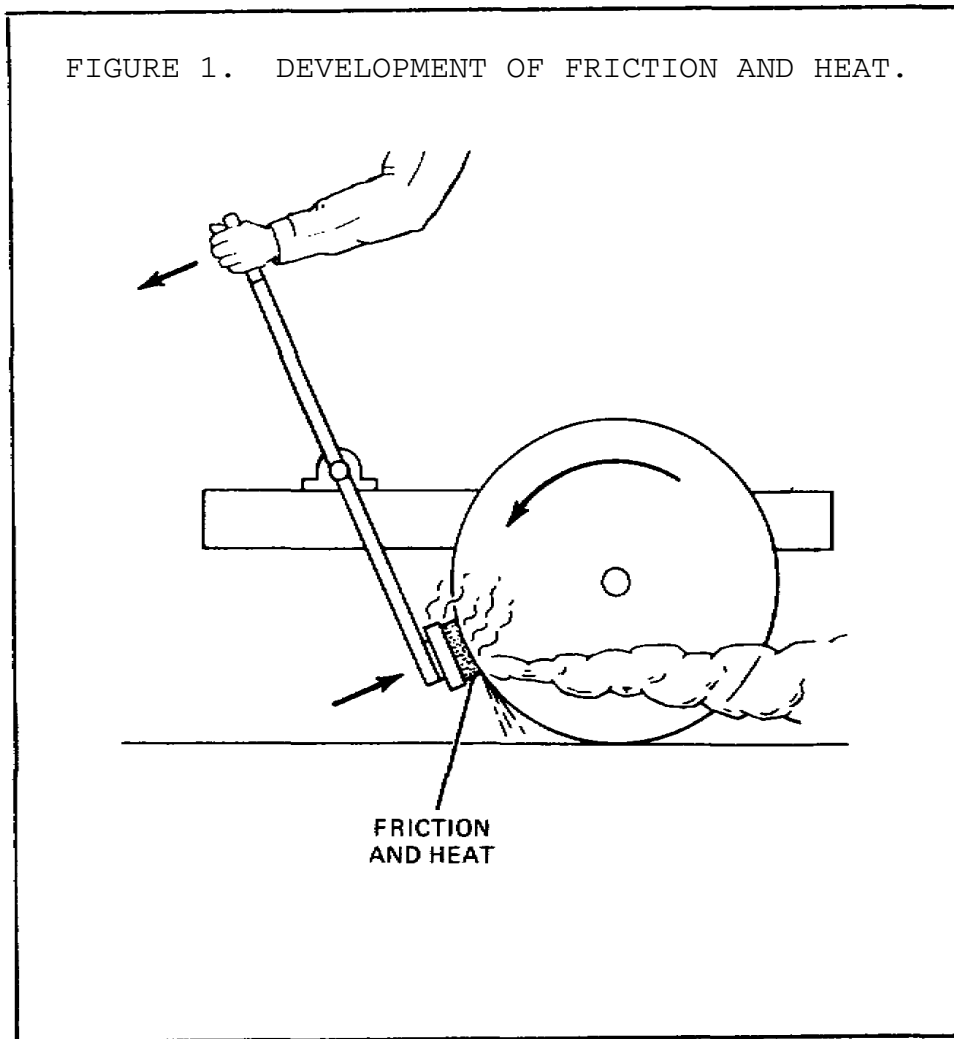

Brakes on early motor vehicles were nothing more than modified wagon brakes used on horse-drawn wagons. These were a hand-operated, mechanical, lever-type brakes that forced a piece of wood against one or more of the wheels. This caused friction or a drag on the wheel or wheels.

There is also friction between the wheel and ground that tries to prevent the wheel from sliding or skidding on the ground. When a vehicle is moving, there is a third force present. This force is known as kinetic energy. This is the name given the force that tries to keep any object in motion once it has started moving.

Lesson 1/Learning Event 1

When the brakes are applied, the wheel will either roll or skid, depending on which is greater, the friction between the braking surfaces or between the wheel and the road. Maximum retardation (slowing down) is reached when friction between the brake surfaces is just enough to almost lock the wheel. At this time, friction between the brake surfaces and wheel and road are almost the same. This is all the friction that can be used in retarding (slowing down) the motion of the vehicle. The amount of friction between the road and the wheel is what limits braking. Should friction between the braking surfaces go beyond this, the braking surfaces will lock and the wheels will skid.

When a wheel rolls along a road, there is no movement between (relative motion) the wheel and road at the point where the wheel touches the road. This is because the wheel rolls on the road surface; but, when a wheel skids, it slides over the surface of the road, and there is relative motion because the wheel is not turning while moving over the road. When a wheel skids, friction is reduced, which decreases the braking effect. However, brakes are made so that the vehicle operator is able to lock the wheels if enough force to the brake lever or pedal is applied.

BRAKING REQUIREMENTS

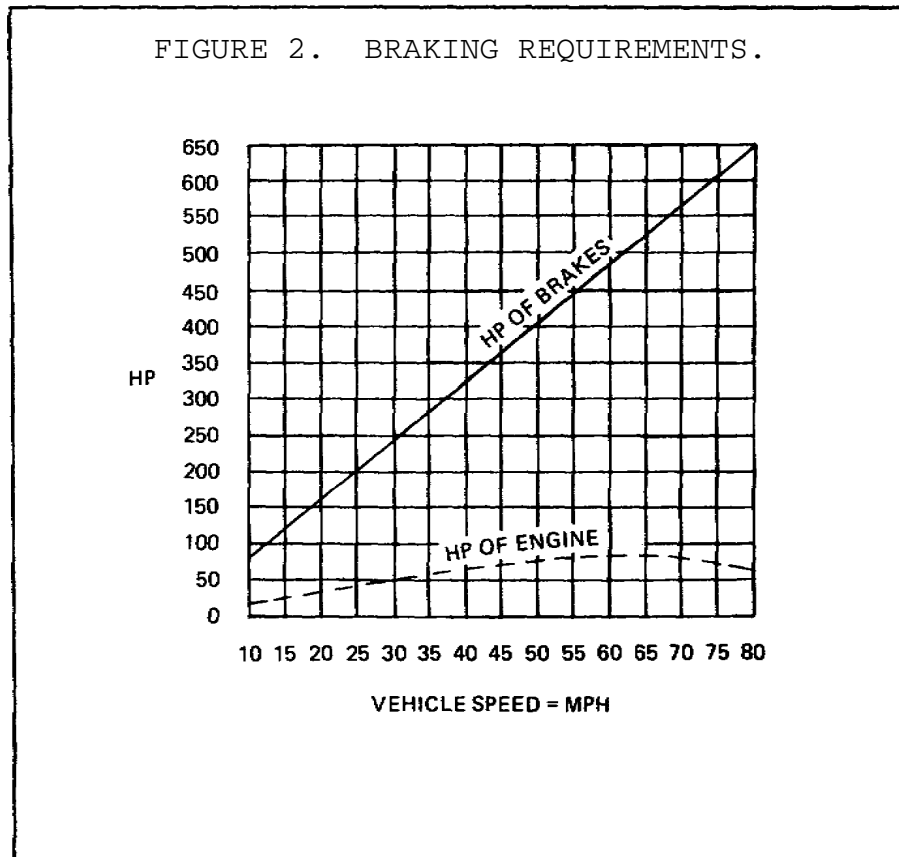

Most of us know that to increase a vehicle's speed requires an increase in the power output of the engine. It is just as true that an increase in speed requires an increase in the braking action necessary to bring a vehicle to a stop. Brakes must not only be able to stop a vehicle, but must stop it in as short a distance as possible. Because brakes are expected to decelerate (slow down) a vehicle at a faster rate than the engine can accelerate it, they must be able to control a greater power than that developed by the engine. This is the reason that well-designed, powerful brakes have to be used to control the modern high-speed motor vehicle. The time needed to stop is one-eighth the time needed to accelerate from a standing start. The brakes then can handle eight times the power developed by the engine.

FACTORS CONTROLLING RETARDATION

The amount of retardation (slowing down) obtained by the braking system of a vehicle is affected by several factors. For wheel brakes used on today's motor vehicles, these factors are the pressure exerted on the braking surfaces (lining and drum), the weight carried on the wheel, the overall radius of the wheel (the distance from the center of the wheel to the outer tread of the tire), the radius of the brake drum, the amount of friction between the braking surfaces, and the amount of friction between the tire and the road. The amount of friction between the tire and the road determines the amount of retardation that can be obtained by the application of the brakes. The things that affect the amount of friction between the tires and the road are the amount and type of tread in contact with the road surface and the type and condition of the road surface. There will be much less friction, and thus much less retardation, on wet or icy roads than on good dry roads.

DRIVER'S REACTION TIME

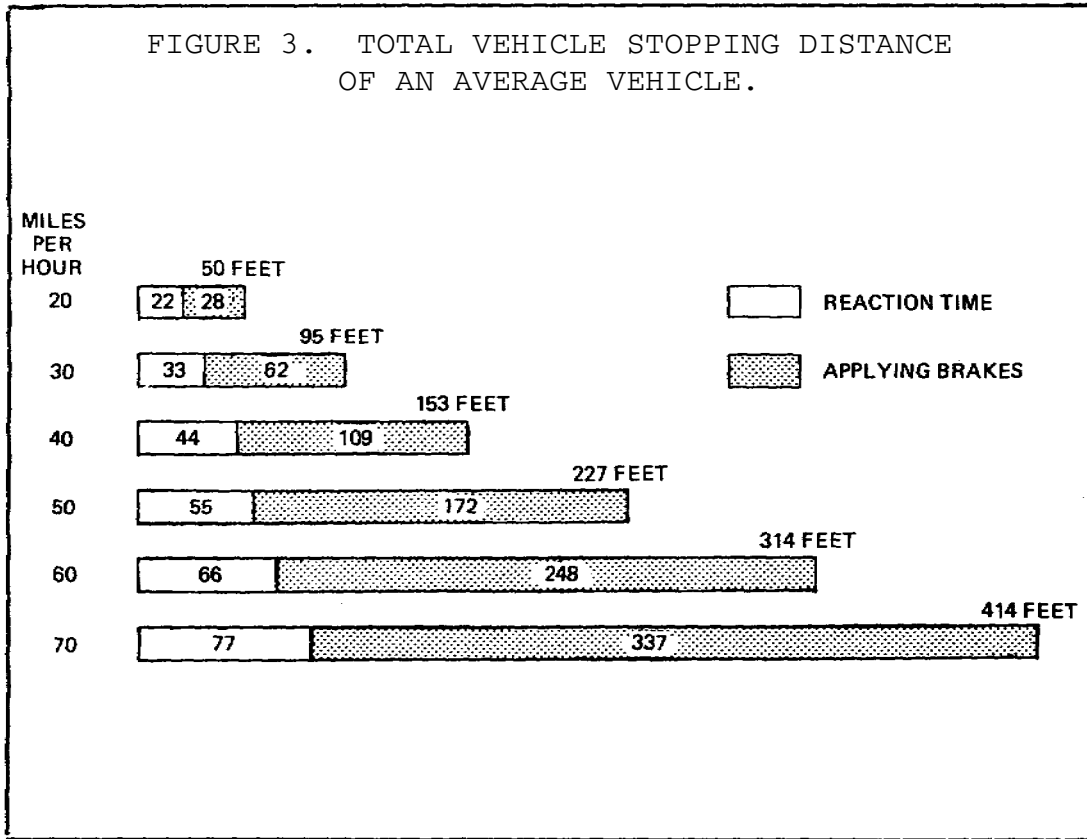

Another factor that affects the time and distance required to bring a vehicle to a stop is the driver's reaction time. Reaction time is the time required for the driver to move his/her foot from the accelerator pedal to the brake pedal and apply the brakes. While the driver is thinking of applying the brakes and reacting to do so, the vehicle will move a certain distance. How far it will move depends on its speed. After the brakes are applied, the vehicle will travel an additional distance before it is brought to a stop. The total stopping distance of a vehicle is the total of the distance covered during the driver's reaction time and the distance during which the brakes are applied before the vehicle stops. This illustration shows the total stopping distance required at various vehicle speeds. This is assuming an average reaction time of three-quarters of a second and that good brakes are applied under the most favorable road conditions.

EXTERNAL-CONTRACTING AND INTERNAL-EXPANDING BRAKES

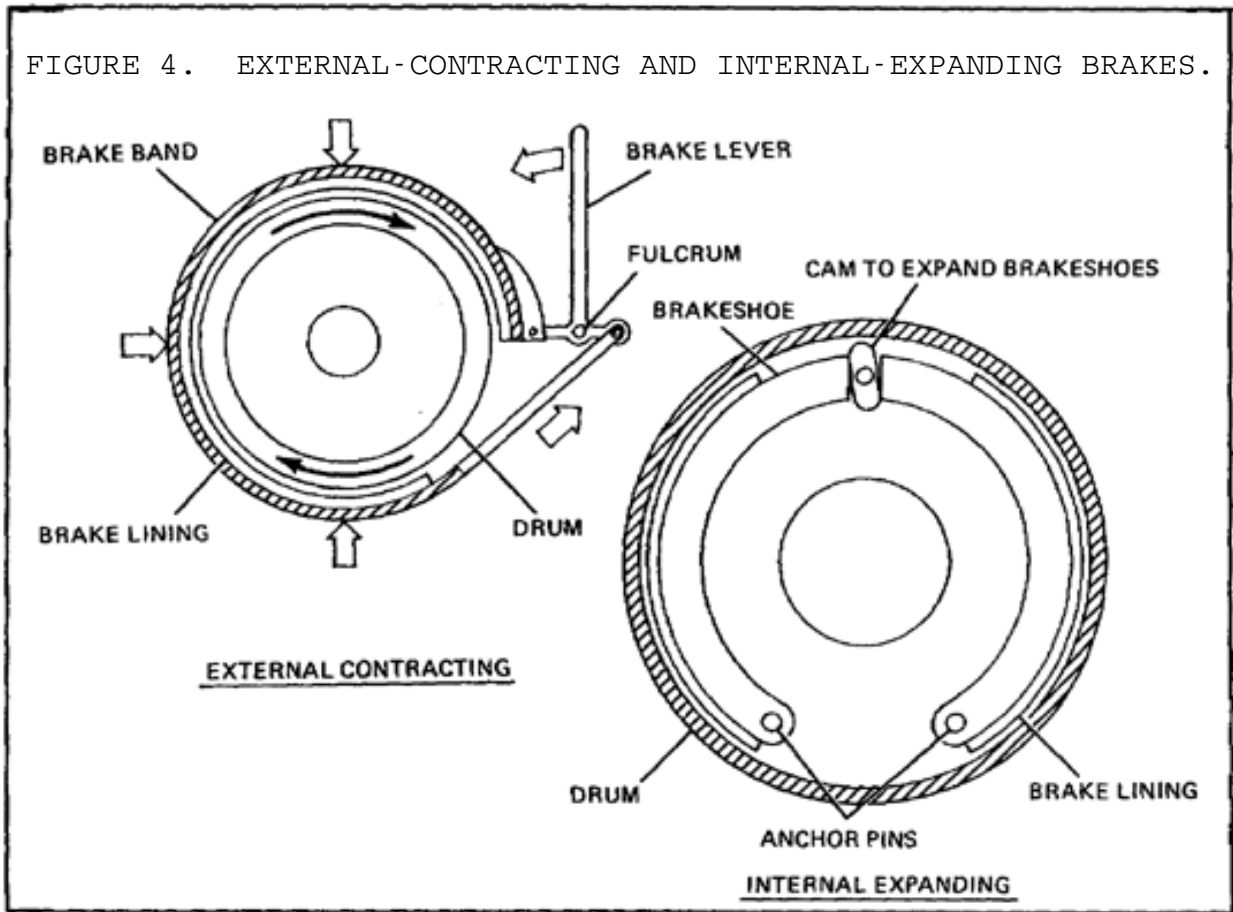

There are several types of braking systems. All systems require the use of a rotating (turning) unit and a nonrotating unit. Each of these units contains braking surfaces that, when rubbed together, give the braking action. The rotating unit on military wheeled vehicle brakes consists of a drum secured to the wheel. The nonrotating unit consists of brake shoes and the linkage needed to apply the shoes to the drum. Brakes are either the external-contracting or internal-expanding type, depending on how the nonrotating braking surface is forced against the rotating braking surface.

When a brake shoe or a brake band is applied against the outside of a rotating brake drum, the brake is known as an external-contracting brake. On this type of brake, the nonrotating braking surface must be forced inward against the drum to produce the friction necessary for braking. The brake band is tightened around the drum by moving the brake lever. Unless an elaborate cover is provided, the external-contracting brake is exposed to dirt, water, and other foreign matter which rapidly wears the lining and drum. This is particularly true with wheel brakes.

The nonrotating unit may be placed inside the rotating drum with the drum acting as a cover for the braking surfaces. This type of brake is known as an internal-expanding brake because the nonrotating braking surface is forced outward against the drum to produce braking action. This type of brake is used on the wheel brakes of cars and trucks because it permits a more compact and economical construction. The brake shoes and brake-operating mechanism may be mounted on a backing plate or brake shield made to fit against and close the open end of the brake drum. This protects the braking surfaces from dust and other foreign matter.

Some vehicles are fitted with a third type of brake system known as disk brakes. The rotating member is known as the rotor. A brake pad is positioned on each side of the rotor. The brakes operate by squeezing together and grasping the rotor to slow or stop the disk.

BRAKE DRUMS

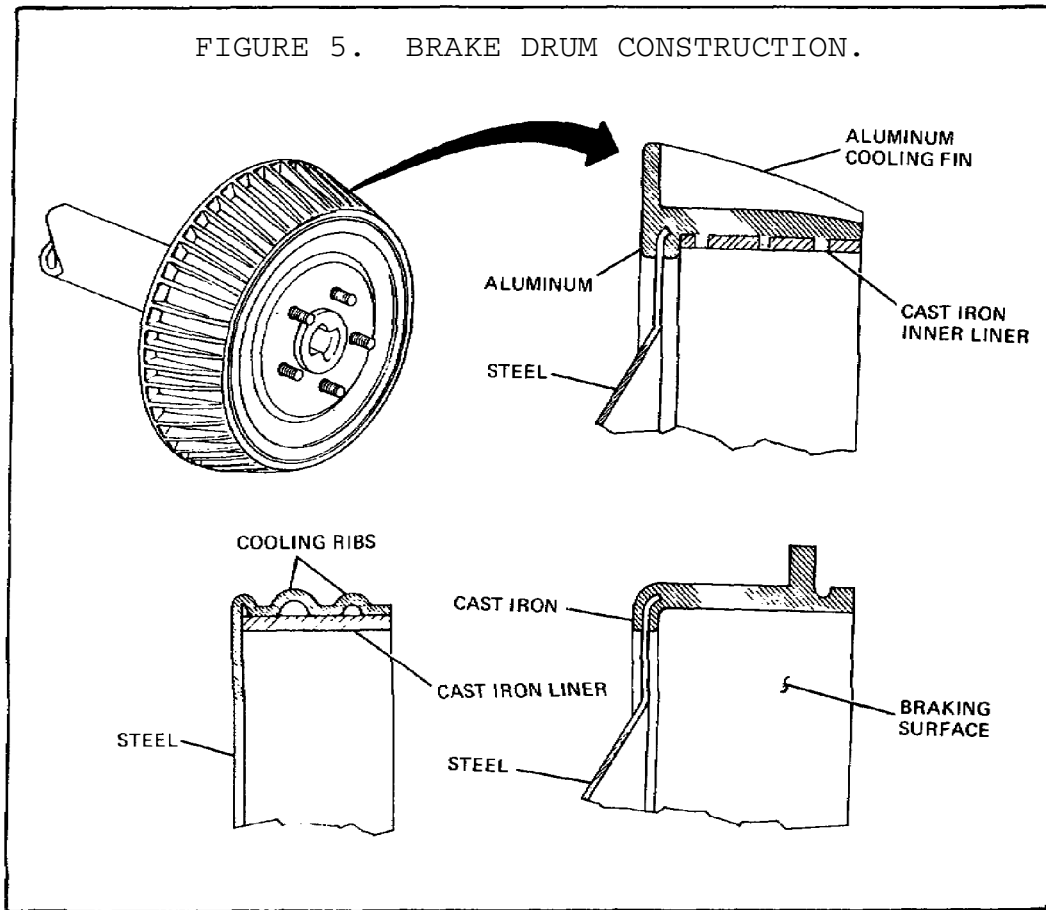

The brake drums are usually made of pressed steel, cast iron, or a combination of the two metals. Cast-iron drums dissipate the heat produced by friction more rapidly than steel drums and have better friction surfaces. However, if a cast-iron drum is made as strong as it should be, it will be much heavier than a steel drum.

To provide light weight and enough strength, some drums are made of steel with a cast-iron liner for the braking surface. This type is known as a centrifuse brake drum. Cooling ribs are sometimes added to the outside of the drum to give more strength and better heat dissipation. Braking surfaces of drums may be ground, or they may be machined to a smooth finish.

For good braking action, the drum should be perfectly round and have a uniform surface. Brake drums become "out of round" from pressure exerted by the brake shoes or bands and from the heat produced by the application of the brakes. The brake drum surface becomes scored when it is worn by the braking action. When the surface is badly scored or the drum is out of round, it is necessary to replace the drum or regrind it or turn it down in a lathe until the drum is again smooth and true.

BRAKE SHOES

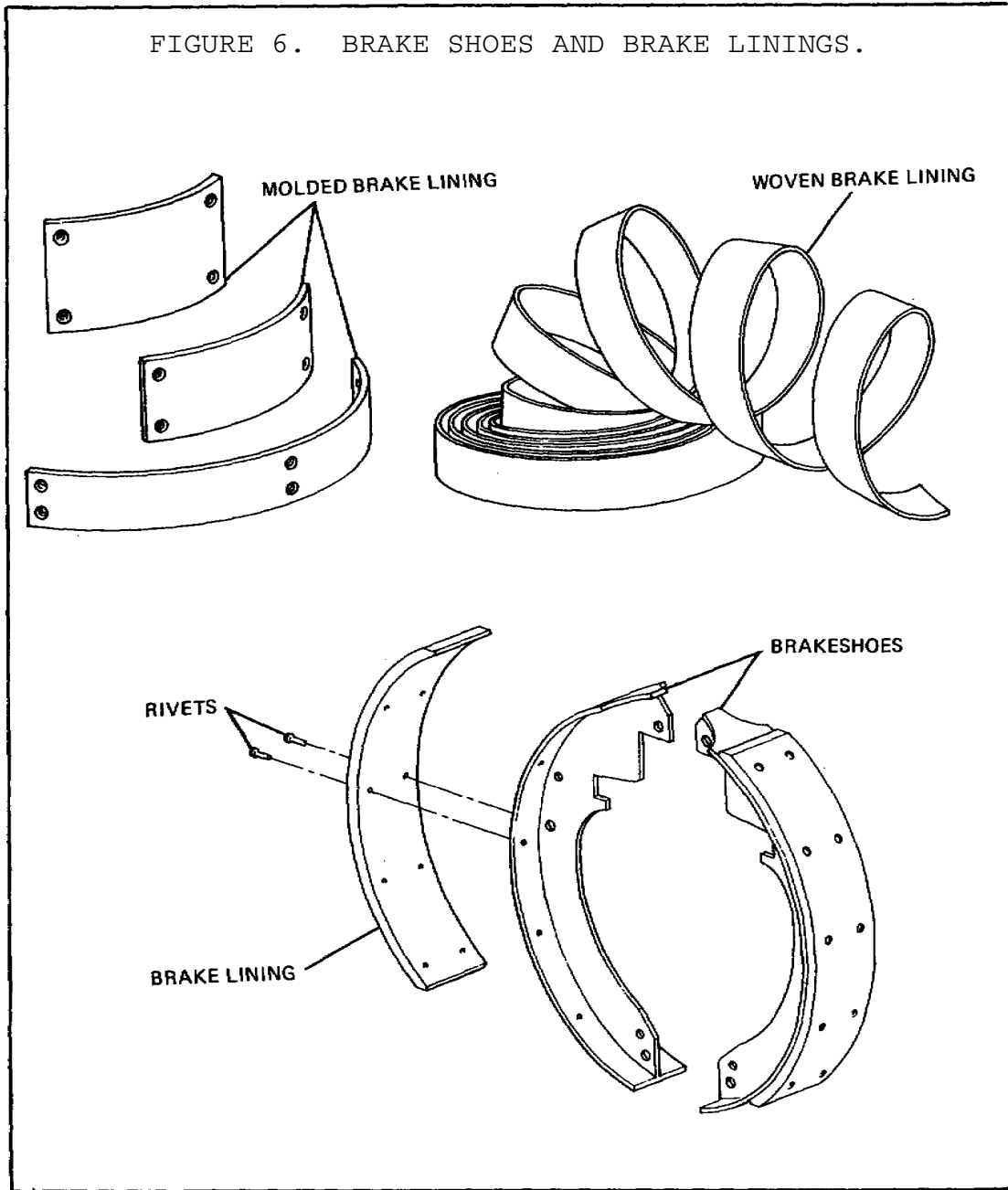

Brake shoes are made of malleable iron, cast steel, drop-forged steel, pressed steel, or cast aluminum. Pressed steel is usually used because it is cheaper to produce in large quantities. Steel shoes expand at approximately the same rate as the drum when heat is produced by brake application, thereby maintaining the clearance between the brake drum and the brake shoe under most conditions.

A friction lining riveted or bonded to the face of the shoe makes contact with the inner surface of the brake drum when the brake is applied. On the riveted-type lining, brass rivets are usually used because brass does not unduly score the drum when the lining is worn. Aluminum rivets are not very satisfactory because they are corroded very readily by salt water. The bonded lining is not riveted but is bonded directly to the shoe with a special cement.

Differences in brake design and conditions of operation make it necessary to have various types of brake linings.

- The molded brake lining is made of dense, hard, compact materials and is cut into blocks to fit different sizes of brake shoes. Its frictional qualities are low because it has a smooth surface, but it dissipates heat rapidly and wears longer than the woven type.
- The woven brake lining is made of asbestos fiber, cotton fiber, and copper or bronze wire. After being woven, the lining is treated with compounds intended to lessen the effects of oil and water if they should come in contact with the lining. However, oil, in particular, will reduce the frictional quality of the lining even after treatment. The lining is also compressed and heat treated before being installed. The main advantage of a woven lining is its frictional qualities. However, it does not dissipate heat as rapidly or wear as well as molded brake linings. This type of lining is generally not used in automotive vehicles.

ROTATING AND NONROTATING UNITS

The brake drum is mounted directly onto the wheel and provides the rotating braking surface. The brake shield, sometimes known as the backing plate or dust shield, is mounted on some fixed structure such as the axle housing. The brake shield forms a support for the nonrotating braking surface (brake shoes) and its operating mechanism.

The brake shoes may be anchored to the brake shield by separate pins or the same pin. Springs or clips are usually used to hold the shoes close to the brake shield and to prevent them from rattling. A fairly strong retracting spring is hooked between the shoes to pull them away from the drum when the brakes are released. With a mechanical hookup, pressure can be applied to the brake shoes by means of a cam, toggle, or double-lever arrangement. A cam turned by a small lever is the method most frequently used. Turning the cam by the lever tends to spread the brake shoes and push them outward against the drum. With the hydraulic system, pressure is applied to the brake shoes by means of a cylinder and pistons.

SELF-ENERGIZING ACTION

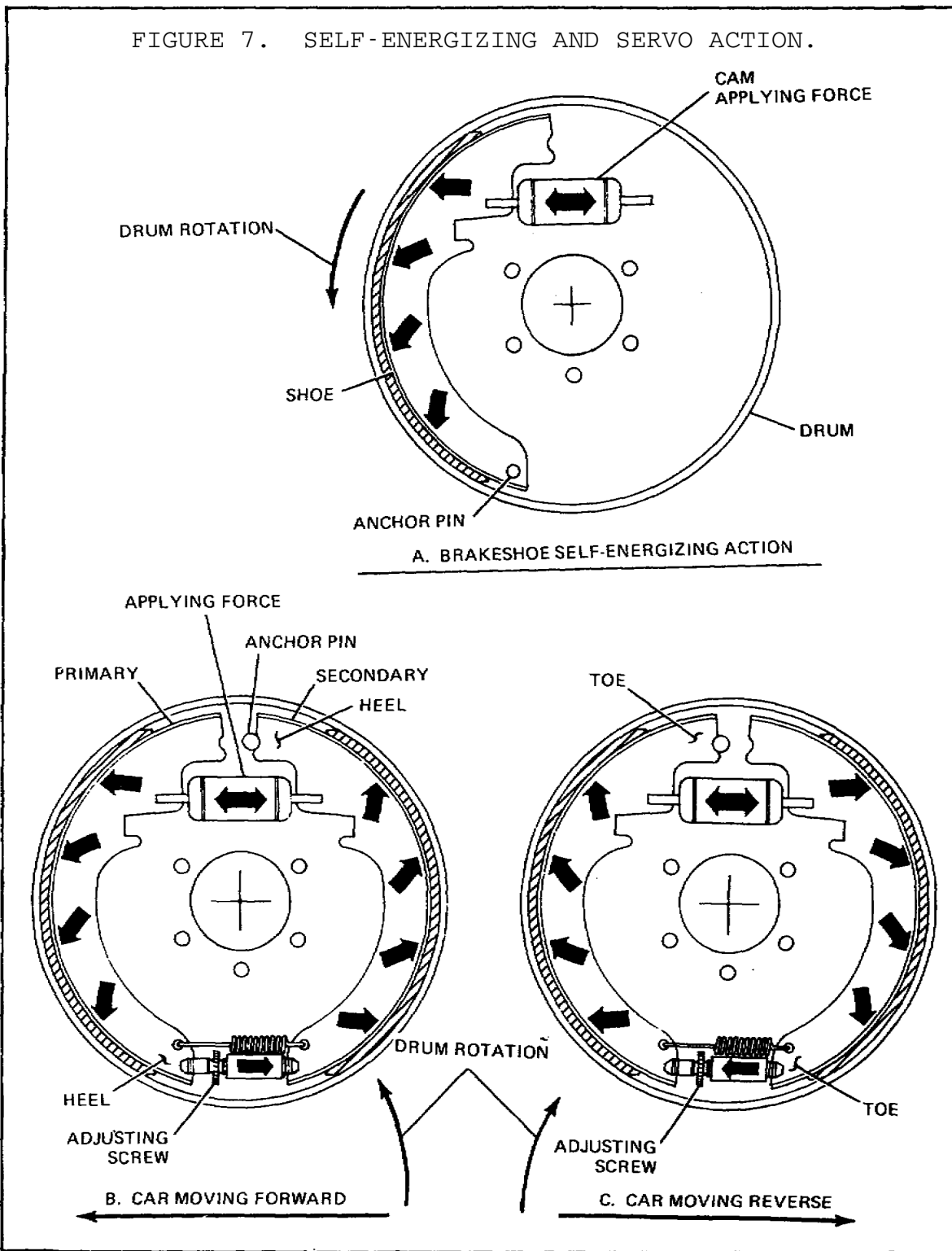

Lesson 1/Learning Event 1

The brake operating linkage alone does not provide enough mechanical advantage for good braking. Some way of increasing the pressure of the brake shoes is needed. A self-energizing action can be used to do this, once the setting of the shoes is started by the movement of the linkage. There are several variations of this self-energizing action, but it is always done by the shoes themselves as they tend to turn with the turning drum.

When the brake shoe is anchored and the drum turns in the direction shown, the shoe will tend to turn with the drum when it is forced against the drum. Friction is trying to cause the shoe to turn with the drum. When this happens, the shoe pushes against the anchor pin. Since the pin is fixed to the brake shield, this pressure tends to wedge the shoe between the pin and drum. As the cam increases the pressure on the shoes, the wedging action increases and the shoe is forced still more tightly against the drum to increase the friction. This self-energizing action results in more braking action than could be obtained by the pressure of the cam against the shoes alone. Brakes making use of this principle to increase pressure on the braking surfaces are known as self-energizing brakes.

It is very important that the operator control the total braking action at all times, which means the self-energizing action should increase only upon the application of more pressure on the brake pedal. The amount of self-energizing action available depends mainly on the location of the anchor pin. As the pin is moved toward the center of the drum, the wedging action increases until a point is reached where the shoe will automatically lock. The pin must be located outside this point so that the operator can control the braking.

When two shoes are anchored on the bottom of the brake shield, self-energizing action is effective on only one shoe. The other shoe tends to turn away from its pivot. This reduces its braking action. When the wheel is turning in the opposite direction, the self-energizing action is produced on the opposite shoe.

Two shoes can be mounted so that self-energizing action is effective on both. This is done by pivoting the shoes to each other and leaving the pivot free of the brake shield. The only physical effort required is for operating the first or primary shoe. Both shoes then apply more pressure to the braking surfaces without an increase in pressure on the brake pedal. The anchor pins are fitted into slots in the free ends of the brake shoes. This method of anchoring allows the shoes to move and expand against the drum when the brakes are applied. The self-energizing action of the primary shoe is transmitted through the pivot to the secondary shoe. Both shoes will tend to turn with the drum and will be wedged against the drum by one anchor pin. The other anchor pin will cause a similar action when the wheel is turning in the opposite direction.

Another type of brake shoe that has been used consists of two links anchored together on the brake shield with the end of each link pivoted to one of the brake shoes. This allows more even application of the braking surface because of the freedom of movement for the brake shoes. Each shoe is self-energizing in opposite directions.

DISK BRAKES

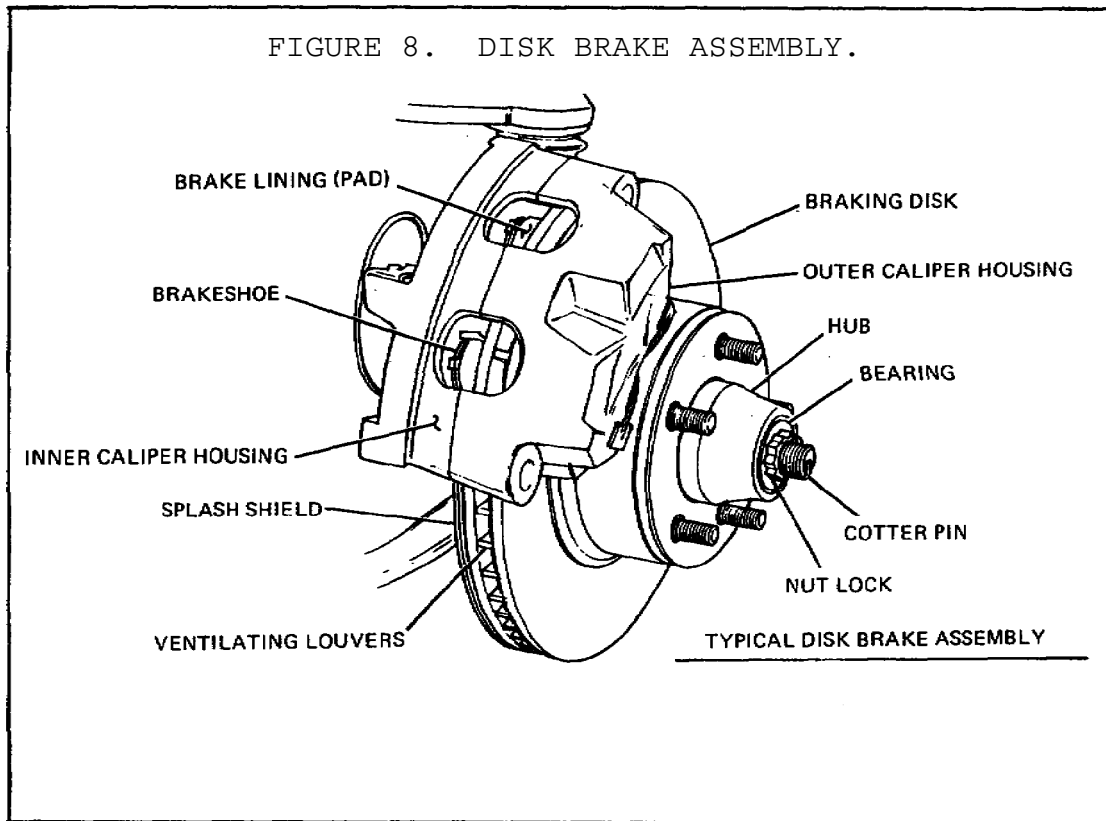

The disk brake, like the drum brake assembly, is operated by pressurized hydraulic fluid. The fluid, which is routed to the calipers through steel lines and flexible high-pressure hoses, develops its pressure in the master cylinder. Once the brake pedal is depressed, fluid enters the caliper and begins to force the piston (s) outward. This outward movement forces the brake pads against the moving rotor. Once this point is reached, the braking action begins. The greater the fluid pressure exerted on the piston(s) from the master cylinder, the tighter the brake pads will be forced against the rotor. This increase in pressure also will cause an increase in braking effect. As the pedal is released, pressure diminishes and the force on the brake pads is reduced. This allows the rotor to turn more easily. Some calipers allow the brake pads to rub lightly against the rotor at all times in the released position. Another design uses the rolling action of the piston seal to maintain a clearance of approximately 0.005 inches when the brakes are released.

Comparison to Drum Brakes

Both the disk and brake drum assemblies used on modern vehicles are well-designed systems. Each system exhibits certain inherent advantages and disadvantages. The most important points of interest are discussed below. One major factor that must be discussed in automotive brakes, as well as all other brake systems, is the system's ability to dissipate heat. As discussed previously, the byproduct of friction is heat. Because most brake systems use this concept to develop braking force, it is highly desirable for brake systems to dissipate heat as rapidly and efficiently as possible. The disk brake assembly, because of its open design, has the ability to dissipate heat faster than the brake drum. This feature makes the disk brake assembly less prone to brake fade due to a buildup of excess heat. The disk assembly also may have additional heat transfer qualities due to the use of a ventilated rotor. This type of rotor has built-in air passages between friction surfaces to aid in cooling.

While the brake drum assembly requires an initial shoe-to-drum clearance adjustment and periodic checks, the disk brake assembly is self-adjusting and maintains proper adjustment at all times. The disk assembly automatically compensates for lining wear by allowing the piston in the caliper to move outward, thereby taking up excess clearance between pads and rotor.

The disk system is fairly simplistic in comparison to the drum system. Due to this design and its lack of moving parts and springs, the disk assembly is less likely to malfunction. Over-hauling the disk brake assembly is faster because of its simplistic design. It also is safer due to the fact that the disk brake assembly is open and asbestos dust from linings is less apt to be caught in the brake assembly. Like brake drums, rotors may be machined if excessive scoring is present. Rotors also are stamped with a minimum thickness dimension which should not be exceeded. The drum brake assembly requires that the drum be removed for lining inspection, while some disk pads have a built-in lining wear indicator that produces an audible high-pitch squeal when linings are worn excessively. This harsh squeal is a result of the linings wearing to a point, allowing a metal indicator to rub against the rotor as the wheel turns. Because of its small frictional area and lack of self-energizing and servo effect, the disk brake assembly requires the use of an auxiliary power booster to develop enough hydraulic pressure for satisfactory braking.

Floating Caliper

The floating caliper is designed to move laterally on its mount. This movement allows the caliper to maintain a centered position with respect to the rotor. This design also permits the braking force to be applied equally to both sides of the rotor. The floating caliper usually is a one-piece solid construction and uses a single piston to develop the braking force. This type of caliper operates by pressurized hydraulic fluid like all other hydraulic calipers. The fluid under pressure first enters the piston cavity and begins to force the piston outward. As this happens, the brake pad meets the rotor. Additional pressure then forces the caliper assembly to move in the opposite direction of the piston, thereby forcing the brake pad on the opposite side of the piston to engage the rotor. As pressure is built up behind the piston, it then forces the brake pads tighter against the rotor to develop additional braking force.

Fixed Caliper

The fixed caliper is mounted rigidly to the spindle or splash shield. In this design, the caliper usually is made in two pieces and has either two, three, or four pistons in use. The pistons, which may be made of cast iron, aluminum, or plastic, are provided with seals and dust boots and fit snugly in bores machined in the caliper. The centering action of the fixed caliper is accomplished by the pistons as they move in their bores. If the lining should wear unevenly on one side of the caliper, the excess clearance would be taken up by the piston simply by moving further out in its bore. As the brakes are applied, the fluid pressure enters the caliper on one side and is routed to the other through an internal passageway or an external tube connected to the opposite half of the caliper. As pressure is increased, the pistons force the brake pads against the rotors evenly and therefore maintain an equal amount of pressure on both sides of the rotor.

As discussed above, the fixed calipers use a multi-piston design to provide the braking force. The fixed calipers may be designed to use two, three, or four pistons. The dual-piston design provides a slight margin of safety over a single-piston floating caliper. In the event of a piston seizing in the caliper, the single-piston caliper would be rendered useless, while the dual-piston design would still have one working piston to restore some braking ability. The three- and four-piston design provides for the use of a large brake lining. The brake force developed may now be spread over a larger area of the brake pad.

MECHANICAL BRAKE SYSTEMS

On wheeled vehicles, the energy supplied by the operator's foot pushing down on the brake pedal is transferred to the brake mechanism on the wheels by various means. A mechanical hookup was used on the first motor vehicles. Now, mechanically-operated braking systems are practically obsolete. However, mechanical hookups are still used for a part of the braking systems in many vehicles.

PARKING BRAKE

The parking brake (auxiliary brake) is generally used to lock the rear wheels or propeller shafts of a vehicle to prevent the vehicle from rolling when it is parked. It can also be used to stop the vehicle in an emergency if the service brakes fail. For this reason, the parking brake is sometimes referred to as the emergency brake.

CONSTRUCTION

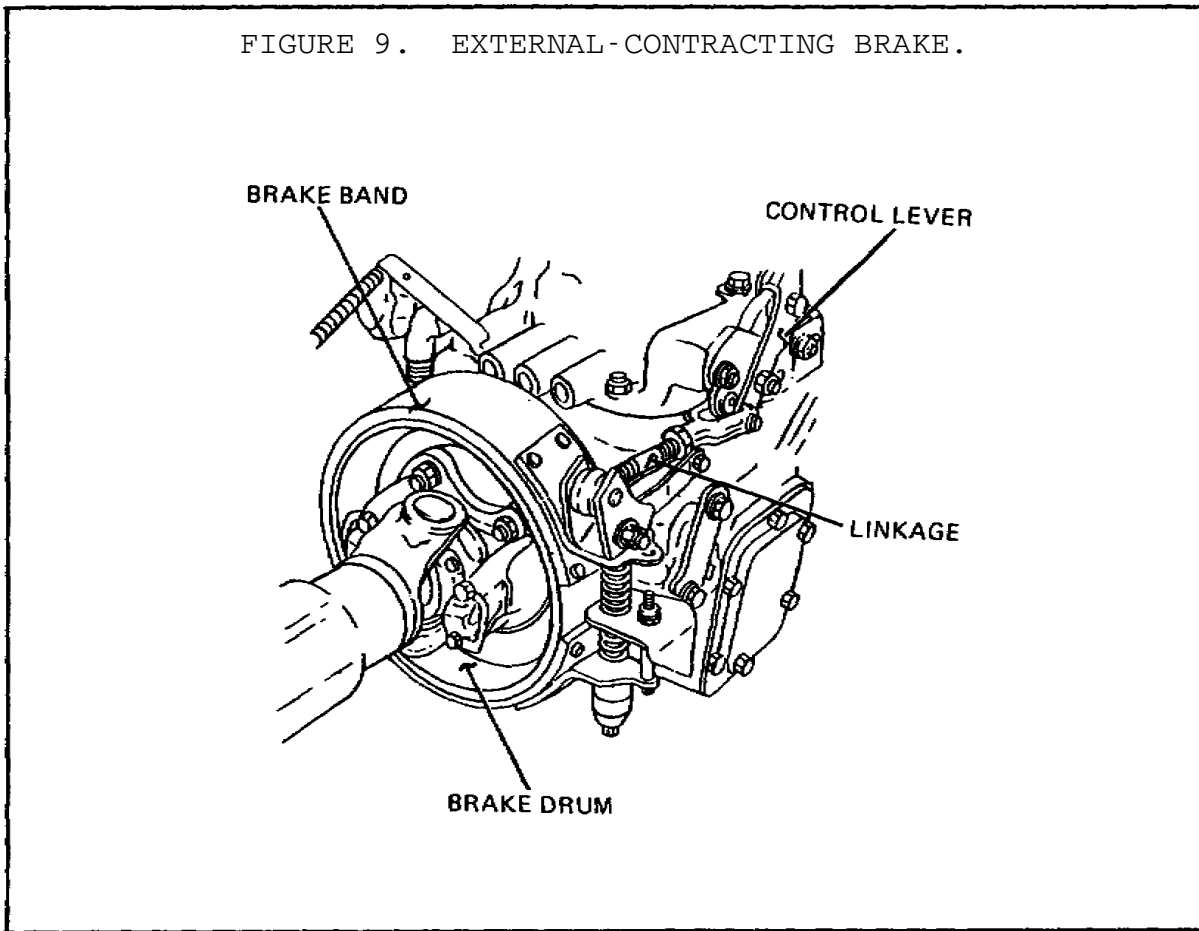

The M151-series trucks use an external-contracting-type brake that is mounted on the transmission or transfer. It has a brake drum that is splined and bolted to a transfer output shaft. A flexible brake band with internal lining is located around the outer circle of the drum. The brake is made to be self-energizing by either forward or backward movement of the vehicle. For this reason, the brake band is anchored at a point just opposite from the point where the operating force is applied. One-half of the band will then wrap tighter (self-energize) on the drum in one direction and the other half in the opposite direction. The mechanism for operating the brake is usually a simple bell crank arrangement controlled by a hand lever. Applying the brake locks the transmission or transfer output shaft, which, in turn, locks the propeller shaft holding the wheels through the axle assembly. When the hand lever is in the released position, the brake band is released by spring pressure.

The parking brake system of the M880- and M1008-series vehicles uses the rear wheel drum brakes to hold the vehicle motionless. When the operator of the vehicle applies the parking brake, the effort with which the brake lever is moved is transmitted to the rear shoes by cables. Levers in the system multiply the physical effort of the operator enough to force the rear brake shoes into tight contact with the drums.

The parking brake system of the M998-series vehicles use a disk mounted on the rear differential propeller shaft to hold the vehicle motionless. When the operator of the vehicle applies the parking brake, a mechanical linkage multiplies the force of the operator, and transmits this increased pressure to the brake unit. The brake unit uses the force to push the brake pads against the drum.

Some large trucks use a parking brake that has a drum with internal-expanding brake shoes similar to the service brakes. Braking action is obtained by clamping the rotating drum between two brake shoes. The lining on the brake shoes contacts the friction surfaces of the drum.

The 2 1/2- and 5-ton military trucks have a parking brake that operates by clamping the flange of a drum between brake shoes. Although it is constructed somewhat different, it uses the same operating principles as the disk brake. The brake is mounted on the rear of the transfer and locks the wheels through the axle assemblies and propeller shafts. The drum has a flange with both inner and outer braking surfaces. Brake shoes with linings are located on the inside as well as the outside of the drum. The outer brake shoe is supported by the pivots on an anchor at its lower end. The inner brake shoe is supported by the brake shoe lever, which is pinned to the center of both the outer and inner brake shoes. Pulling the brake shoe lever moves the brake shoes together clamping the drum flange between them.

Learning Event 2:

DESCRIBE THE CONSTRUCTION AND OPERATION OF HYDRAULIC BRAKE SYSTEMS

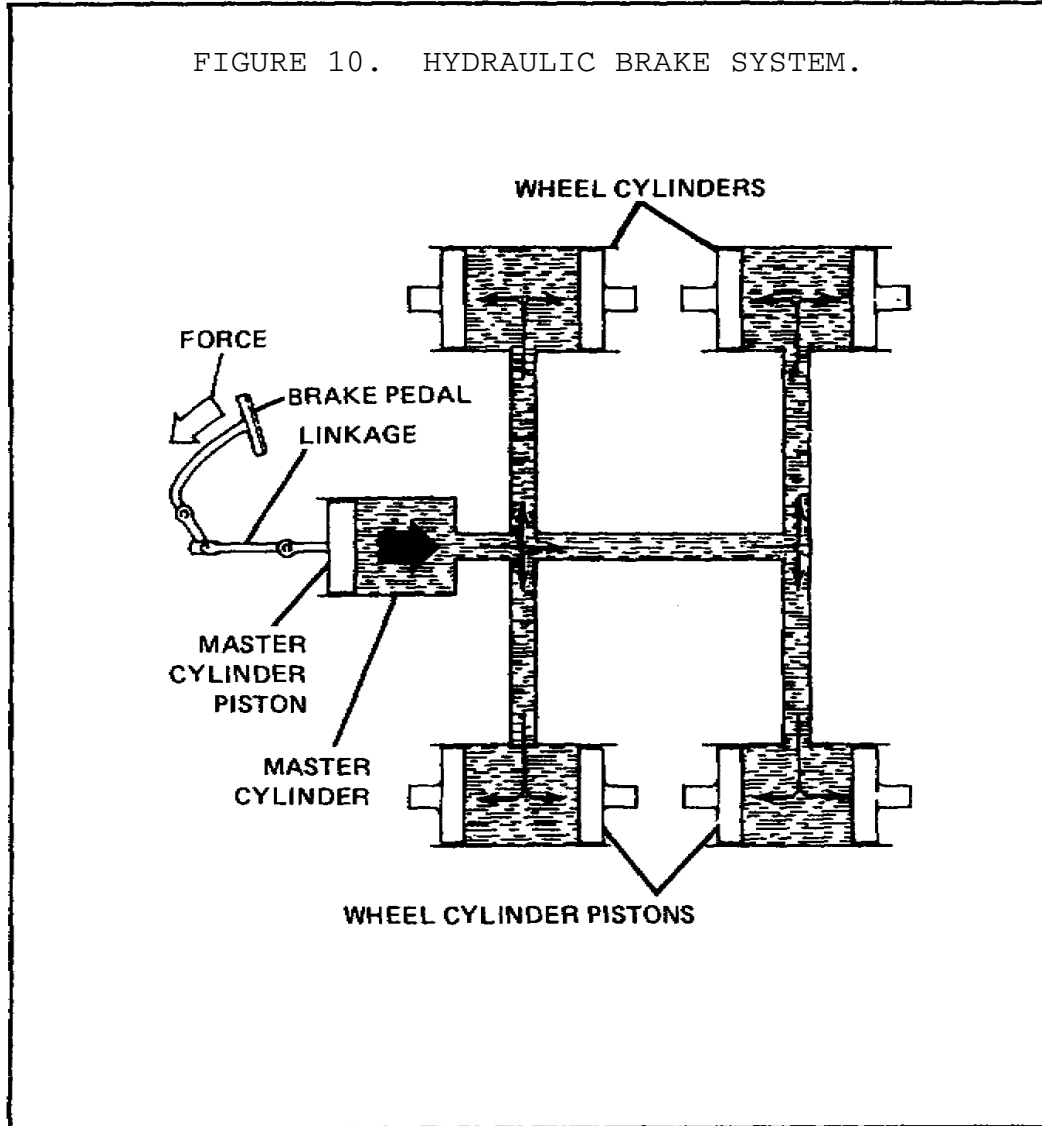

In hydraulic braking systems, the pressure applied at the brake pedal is transmitted to the brake mechanism by a liquid. Since a liquid cannot be compressed under ordinary pressures, force is transmitted solidly just as if rods were used. Force exerted at any point upon a confined liquid is distributed equally through the liquid in all directions so that all brakes are applied equally.

In a hydraulic brake system, the force is applied to a piston in a master cylinder. The brake pedal operates the piston by linkage. Each wheel brake is provided with a cylinder. Inside the cylinder are opposed pistons which are connected to the brake shoes. When the brake pedal is pushed down, linkage moves the piston within the master cylinder, forcing the brake liquid or fluid from the cylinder. From the master cylinder, the fluid travels through tubing and flexible hose into the four wheel cylinders.

The brake fluid enters the wheel cylinders between the opposed pistons. The pressure of the brake fluid on the pistons causes them to move out. This forces the brake shoes outward against the brake drum. As pressure on the pedal is increased, more hydraulic pressure is built up in the wheel cylinders and more force is exerted against the ends of the brake shoes.

When the pressure on the pedal is released, retracting (return) springs on the brake shoes pull the shoes away from the drum. This forces the wheel cylinder pistons to their release positions and also forces the brake fluid back through the flexible hose and tubing to the master cylinder.

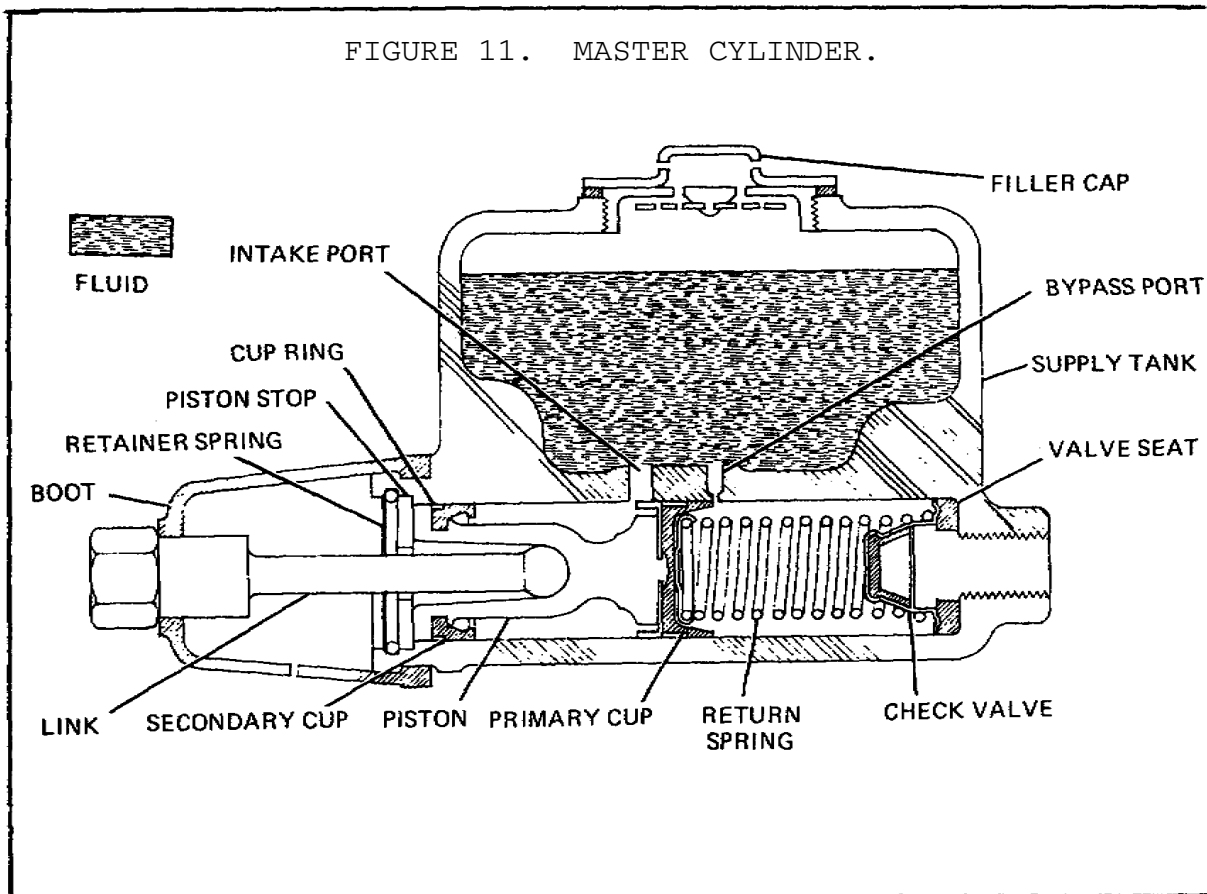

The master cylinder housing is an iron casting which contains the cylinder and a large reservoir for the brake fluid. The reservoir carries enough reserve fluid to ensure proper operation of the braking system. It is filled through a hole at the top which is sealed by a removable filler cap containing a vent. The cylinder is connected to the reservoir by two drilled holes or ports, a large intake port, and a small bypass port.

The master cylinder piston is a long, spool-like member with a rubber secondary cup seal at the outer end and a rubber primary cup which acts against the brake liquid just ahead of the inner end. The primary cup is kept against the end of the piston by a return spring. The inner piston head has several small bleeder ports that pass through the head to the base of the rubber primary cup. A steel stop disk, held in the outer end of the cylinder by a retaining spring (snap ring), acts as a piston stop. A rubber boot covers the piston end of the master cylinder to prevent dust and other foreign matter from entering the cylinder. This boot is vented to prevent air from being compressed within it.

In the outlet end of the cylinder is a combination inlet and outlet valve which is held in place by the piston return spring. This check valve is a little different from most check valves that will let fluid pass through them in one direction only. If enough pressure is applied to this valve, fluid can go either through or around it in either direction. This means it will keep some pressure in the brake lines. The check valve consists of a rubber valve cup inside a steel valve case which seats on a rubber valve seat that fits in the end of the cylinder. In some designs, the check valve consists of a spring-operated outlet valve seated on a valve cage rather than a rubber cup outlet valve. The principle of operation is the same. The piston return spring normally holds the valve cage against the rubber valve seat to seal the brake fluid in the brake line.

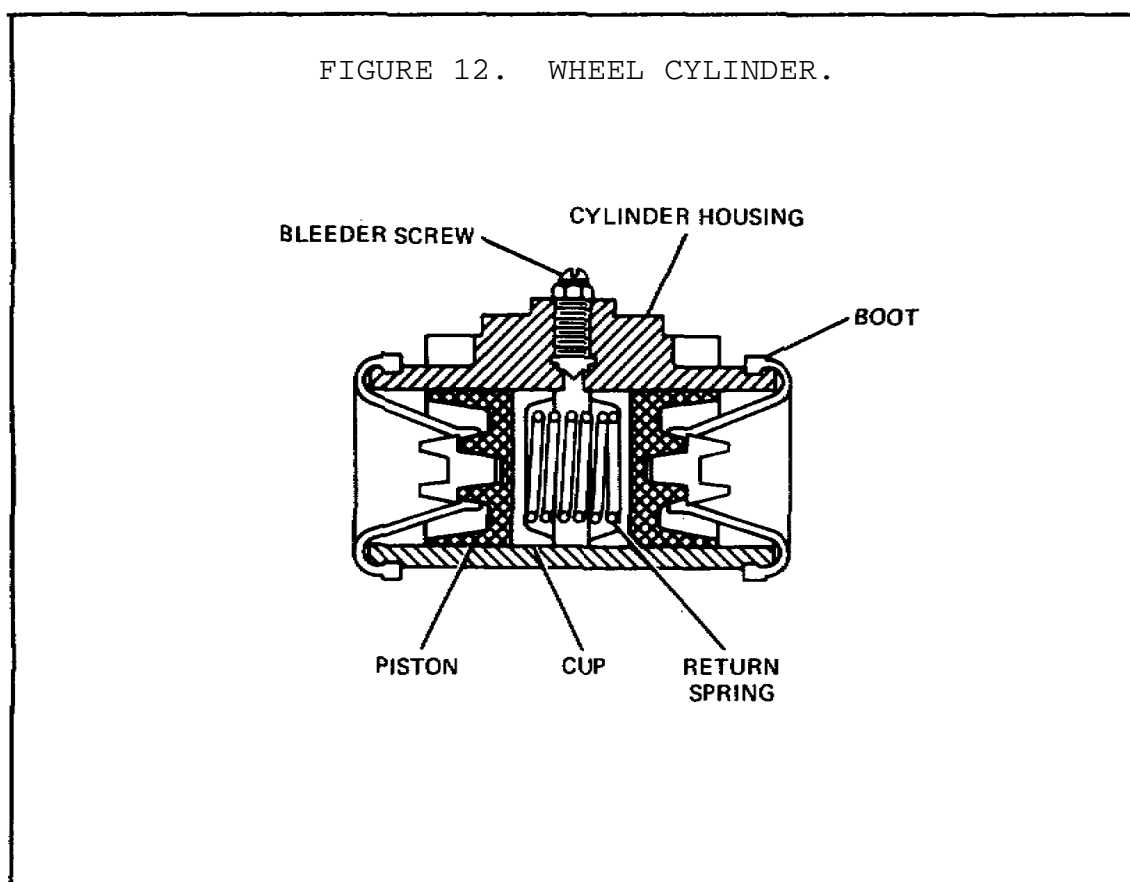

The wheel cylinder changes hydraulic pressure into mechanical force that pushes the brake shoes against the drum. The wheel cylinder housing is mounted on the brake backing plate. Inside the cylinder are two pistons which are moved in opposite directions by hydraulic pressure and which, at the same time, push the shoes against the drum. The piston or piston stems are connected directly to the shoes. Rubber piston cups fit in the

Lesson 1/Learning Event 2

cylinder bore against each piston to prevent the escape of brake liquid. There is a light spring between the cups to keep them in position against the pistons. The open ends of the cylinder are fitted with rubber boots to keep out foreign matter. Brake fluid enters the cylinder from the brake line connection between the pistons. At the top of the cylinder, between the pistons, is a bleeder hole and screw through which air is released when the system is being filled with brake fluid.

On some vehicles, a stepped wheel cylinder is used to compensate for the faster rate of wear on the front shoe than on the rear shoe. This happens because of the self-energizing action. By using a larger piston for the rear shoe, the shoe receives more pressure to offset the self-energizing action of the front shoe.

If it is desired that both shoes be independently self-energizing, it is necessary to have two wheel cylinders, one for each shoe. Each cylinder has a single piston and is mounted on the opposite side of the brake backing plate from the other cylinder.

So far, we have discussed the parts needed to make up a hydraulic brake system. Now let's see what happens to these parts when the brakes are applied and released. Let's assume the master cylinder is installed on a vehicle and the hydraulic system is filled with fluid. As the driver pushes down on the brake pedal, linkage moves the piston in the master cylinder. As the piston moves inward, the primary cup seals off the bypass port (sometimes known as the compensating port).

With the bypass port closed, the piston traps the fluid ahead of it and creates pressure in the cylinder. This pressure forces the check valve to open and fluid passes into the brake line. As the piston continues to move, it forces fluid through the lines into the wheel cylinders. The hydraulic pressure causes the wheel cylinder pistons to move outward and force the brake shoes against the brake drum. As long as pressure is kept on the brake pedal, the shoes will remain pressed against the drum.

When the brake pedal is released, the pressure of the link or pushrod is removed from the master cylinder piston. The return spring pushes the piston back to the released position, reducing the pressure in front of the piston. The check valve slows down the sudden return of fluid from the wheel cylinders. As the piston moves toward the released position in the cylinder, fluid from the master cylinder supply tank flows through the intake port and then through the bleeder holes in the head of the piston. This fluid will bend the lips of the primary cup away from the cylinder wall, and the fluid will flow into the cylinder ahead of the piston.

When the pressure drops in the master cylinder, the brake shoe return springs pull the shoes away from the drum. As the shoes are pulled away from the drum, they squeeze the wheel cylinder pistons together. This forces the brake fluid to flow back into the master cylinder.

The returning fluid forces the check valve to close. The entire check valve is then forced off its seat, and fluid flows into the master cylinder around the outer edges of the valve. When the piston in the master cylinder has returned to its released position against the stop plate, the primary cup uncovers the bypass port and any excess fluid will flow through the bypass port to the reservoir. This prevents the brakes from "locking up" when the heat of the brakes causes the brake fluid to expand.

When the piston return spring pressure is again more than the pressure of the returning fluid, the check valve seats. The valve will keep a slight pressure in the brake lines and wheel cylinders. The brake system is now in position for the next brake application.

Lesson 1/Learning Event 3

Learning Event 3:

DESCRIBE INSPECTION PROCEDURES FOR HYDRAULIC BRAKE SYSTEMS

INTRODUCTION

The hydraulic braking system of the modern high-speed automobile must be kept in a high state of repair. Not too many years ago, a small defect in the braking system did not bother too much; in fact, it might not even have been noticed. Today, however, improved road conditions and higher vehicle speeds, plus more sensitive steering and suspension systems, cause a poor braking action to be noticed immediately. The brake system parts must be able to stand up under high pressures and temperatures and still be able to work properly if the vehicle is to be operated safely. To properly repair a brake system so it is always in top condition, the mechanic must be well trained and have a desire to do the best job possible.

BEFORE ROAD-TEST INSPECTION

The condition of the hydraulic service brakes of a vehicle can be determined by inspecting the following items: fluid level in the master cylinder, brake pedal free travel, total brake pedal travel, feel of brake pedal (hard or spongy), leaks in the hydraulic system, noise during operations, performance, and the amount of wear of brake parts. Wear can normally be determined by checking one wheel of each axle.

To inspect the fluid level in the master cylinder, first clean away all dirt that may fall into the master cylinder reservoir. Remove the filler cap and ensure the fluid level is at the level recommended in the maintenance manual pertaining to the vehicle being serviced. The level of fluid is determined by measuring the distance from the top of the filler hole to the level of fluid in the reservoir.

If the fluid level is low, refer to the vehicle's lubrication order for the recommended type of brake fluid and add fluid as needed. Since the end of 1982, all military vehicles use silicone brake fluid. Silicone fluid does not absorb water, provides good corrosion protection, and has good lubrication qualities. The fluid is also compatible with the rubber components of the brake system.

Check the master cylinder supply tank reservoir vent to make sure that it is not plugged. On some vehicles, a small hole drilled in the filler cap vents the supply tank. On other vehicles, the supply tank is vented through a line and fitting connected to the top of the master cylinder supply tank. A plugged vent can be easily cleared with compressed air.

Measure the brake pedal free travel and compare the measurement with the specifications given in the vehicle's maintenance manual. Brake pedal free travel is the amount that the brake pedal can be moved without moving the master cylinder piston. If the pedal has too much free travel, it will have to be pushed farther before the brakes apply. If there is not enough free travel, it may prevent the brakes from releasing.

To check the total travel of the brake pedal, push the brake pedal down as far as you can. You should not be able to push the brake pedal on most trucks any closer to the floorboard than 2 inches.

- If there is too much pedal travel, but the pedal feels firm, the problem is probably caused by normal wear of the brake lining. When the lining is not worn too badly, an adjustment of the brake shoes will correct excessive pedal travel. Unfortunately, the only way to determine the exact amount of the brake lining wear on most vehicles is to remove the wheels and brake drums.
- If the pedal travel is too great and the pedal feels spongy, there is probably some air in the hydraulic system. Air trapped in the hydraulic system can be compressed and does not permit pressure applied to the pedal to be applied solidly to the brakes. Methods of correcting these problems are covered later in this lesson.

Inspect the hydraulic system for leaks. Large leaks can be detected while checking the pedal travel. This is done by holding a steady pressure on the brake pedal for a few moments. If the pedal continues to move down, there is a large leak. Small leaks cannot be detected this way as they cause the pedal to fall away too slowly to be noticed.

Look the entire hydraulic system over for any visible indications of leakage. Inspect the master cylinder, especially around the rubber boot, for external fluid leaks. Inspect all steel lines (tubes) for leakage, loose fittings, wear, dents, corrosion, and missing retaining clips. Inspect the flexible hoses for leakage, cuts, cracks, twists, and evidence of rubbing against other parts. Inspect the area at the lower edge of the backing plate for the presence of any brake fluid or grease. Leakage of either brake fluid or grease at the wheels is an indication of brake problems.

ROAD-TEST INSPECTION

Road-test the vehicle and check the operation of the brakes by stopping several times while traveling on a smooth road. Check for squeaking or grinding sounds when the brakes are applied, an excessive amount of pressure required on the brake pedal to stop the vehicle, and the vehicle pulling to one side when the brakes are applied (uneven braking).

If the brakes make a squeaking or grinding sound, some of the more common causes are:

- Glazed or worn lining.
- Lining loose on the brake shoes.
- Dirt embedded in the lining.
- Improper adjustment.
- Brake fluid or grease on the lining.
- Scored brake drums or rotors.

NOTE

The wheel and brake drum will have to be removed from the noisy brake and the brake parts inspected to determine the exact cause of the noise.

When excessive pressure must be applied to the brake pedal to stop the vehicle, any one or more of the following items may be the cause:

- Glazed or worn brake lining.
- Improperly adjusted brake shoes.
- Dirt in the brake drums.
- Grease or brake fluid on the lining.
- Faulty master cylinder.
- Binding pedal linkage.
- Restricted brake line.

AFTER ROAD-TEST INSPECTION

If such things as pulling to one side or poor braking action are noted during a road test, an after road-test inspection is done.

Many faults occur in the brake system that can cause the vehicle to pull to one side. However, all these faults have one thing in common: they affect the brake in one wheel causing that wheel to hold either more or less than the other wheels. If the affected wheel holds more, the vehicle will pull toward the affected wheel; if it holds less, the vehicle pulls away from the affected wheel. The most common faults that cause the brakes to hold unevenly are unequal brake adjustment, grease or brake fluid on the lining, dirt in the brake drum, brake drum or rotor scored or rough, different kinds of brake linings on opposite wheels, primary and secondary brake shoes reversed in one wheel (on some vehicles), glazed or worn lining, restricted brake line, weak brake shoe return springs, or sticking pistons in a wheel or caliper cylinder.

If the inspection indicates that the wheel brakes are at fault, you must determine the condition of the brake parts in the wheel brakes. Do this by removing one wheel and brake drum from each axle assembly and inspecting the brake parts in these wheels. It is reasonable to assume that the condition of both brake assemblies on one axle will be about the same. Inspect the condition of the brake drum, brake lining, brake shoe anchor, hold-down springs, retracting (return) springs, brake shoe adjusting mechanism, and wheel cylinder.

This page intentionally left blank.

PRACTICE EXERCISE

1. What is used to slow or stop a vehicle?
 - a. Friction
 - b. Momentum
 - c. Inertia

2. At what point is maximum retardation (slowing down) of a vehicle reached?
 - a. When brakes are first applied
 - b. Just before the brakes lock
 - c. When the brakes lock

3. What is the advantage of self-energizing brakes?
 - a. Smoother brake action
 - b. Increased pressure on the braking surfaces
 - c. Decreases tendency to skid on sudden stops

4. What is the purpose of the light spring between the cups of a wheel cylinder?
 - a. Return the piston to the released position
 - b. Slow down the application of the brakes
 - c. Keep the cups in position against the pistons

5. Which of the following is an advantage of disk brakes over drum brakes?
 - a. Disk brakes fade less
 - b. Disk brakes are self-energizing
 - c. Disk brakes are less expensive

Lesson 1

ANSWERS TO PRACTICE EXERCISE

1. a (page 2)
2. b (page 4)
3. b (page 16)
4. c (page 28)
5. a (page 19)

LESSON 2
AIR-HYDRAULIC BRAKE SYSTEMS

TASK

Describe the principles, construction, and operation of air-hydraulic brake systems.

CONDITIONS

Given information on the purpose, components, operation, and inspection of air-hydraulic brake systems.

STANDARDS

Answer 70 percent of the multiple-choice test items covering fundamentals of air-hydraulic brake systems.

REFERENCES

TM 9-8000

Learning Event 1:

DESCRIBE THE COMPONENTS OF THE AIR-HYDRAULIC BRAKE SYSTEM

INTRODUCTION

Most passenger cars and light-duty trucks have the straight hydraulic brake system which uses only the energy that is applied to the brake foot pedal. This type brake does a good job on light-duty vehicles, but medium- and heavy-duty vehicles require a better braking system. The Army's 2 1/2-ton and some 5-ton tactical design trucks have air-hydraulic brakes. Air-hydraulic brakes have hydraulic and compressed air systems. The hydraulic systems of straight hydraulic brakes and air-hydraulic brakes are about the same. The compressed air system supplies air pressure to boost the hydraulic pressure to the wheel cylinders above the amount supplied from the master cylinder.

TYPICAL BRAKE SYSTEM

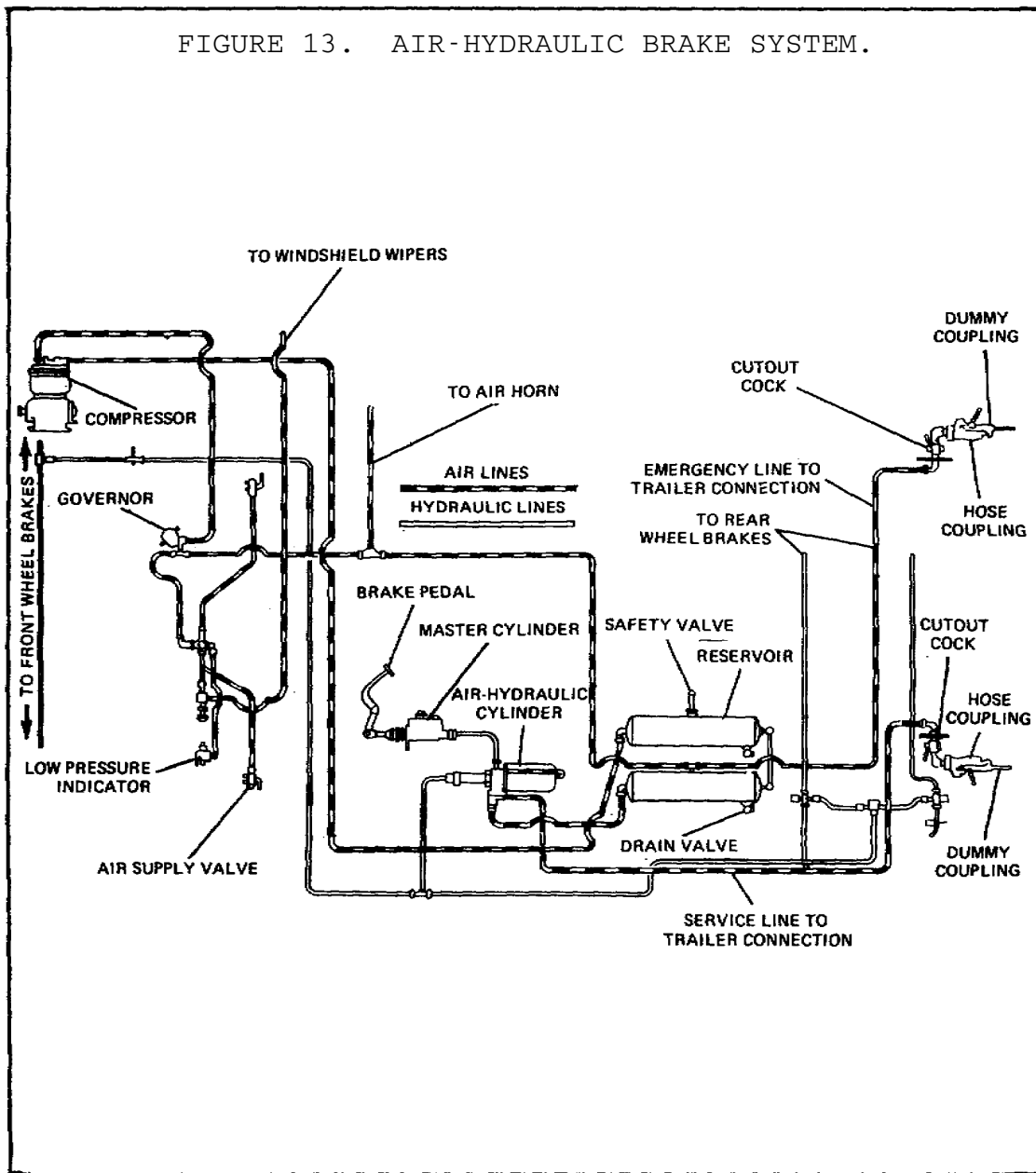

An air-hydraulic brake system has all the components of a straight hydraulic system plus those of the compressed air system. Besides boosting the hydraulic pressure of the brakes on the truck, the compressed air system can also be used to apply the brakes of a trailer and operate accessories such as the wiper motor and horn.

MASTER CYLINDER

The master cylinder used with air-hydraulic brakes is like the one described in the lesson on hydraulic brakes. In straight hydraulic brake systems, the master cylinder receives the initial mechanical force from the pedal linkage, changes it to hydraulic pressure, and sends the brake fluid under pressure directly to the wheel cylinders. In air-hydraulic brakes, the master cylinder sends brake fluid under pressure to an air-hydraulic cylinder before it goes to the wheel cylinders. On all military designed vehicles, the master cylinder has a vent fitting at the top of the reservoir for connecting a vent line to the vent system of the vehicle. This prevents water from entering the master cylinder through the vent during fording operations. The special drilled bolt and fitting installed in the filler cap of the master cylinder serves this purpose.

AIR-HYDRAULIC CYLINDER

The air-hydraulic cylinder is put into operation by the hydraulic pressure from the master cylinder. It uses compressed air to boost the hydraulic pressure from the master cylinder. The Army uses more than one model of air-hydraulic cylinders; all models contain the same major units and operate on the same principles. They are made up of three major units in one assembly. The units are the control unit, power cylinder, and slave cylinder. The units of the M809-series vehicles consist of an air valve, air cylinder, hydraulic cylinder, and piston.

The control unit contains a control valve (relay) piston, which is hydraulically operated by brake fluid from the master cylinder, and a diaphragm or compensator assembly, which is operated by pressure differences between brake fluid and air and spring pressure. A return spring holds the hydraulic relay piston and diaphragm assembly in the released position when there is no hydraulic pressure. Two air poppet valves, assembled on one stem, control the air pressure flowing into and out of the power cylinder. The poppet valves are normally held in the released position by the poppet return spring.

Lesson 2/Learning Event 1

The power cylinder consists of a cylinder, piston, piston rod, and piston return spring. Air pressure admitted at the head end of the cylinder compresses the piston return spring extending the piston rod. When the air pressure is released, the spring retracts the rod. Air in the rod end of the cylinder can pass freely in and out of the cylinder through a breather air line that is attached to the air intake system of the vehicle. A lip-type piston seal prevents air pressure from leaking between the piston and cylinder wall.

The slave cylinder is a hydraulic cylinder containing a piston and piston cup. Some cylinders contain a check valve assembly, at the hydraulic outlet, for maintaining a slight amount of pressure (residual) in the hydraulic lines and wheel cylinders. The piston and piston cup are hollow and contain a check valve that allows brake fluid to pass through freely when the power cylinder is retracted. When the power cylinder extends, the check valve blocks the opening through the center of the slave cylinder piston.

AIR COMPRESSOR

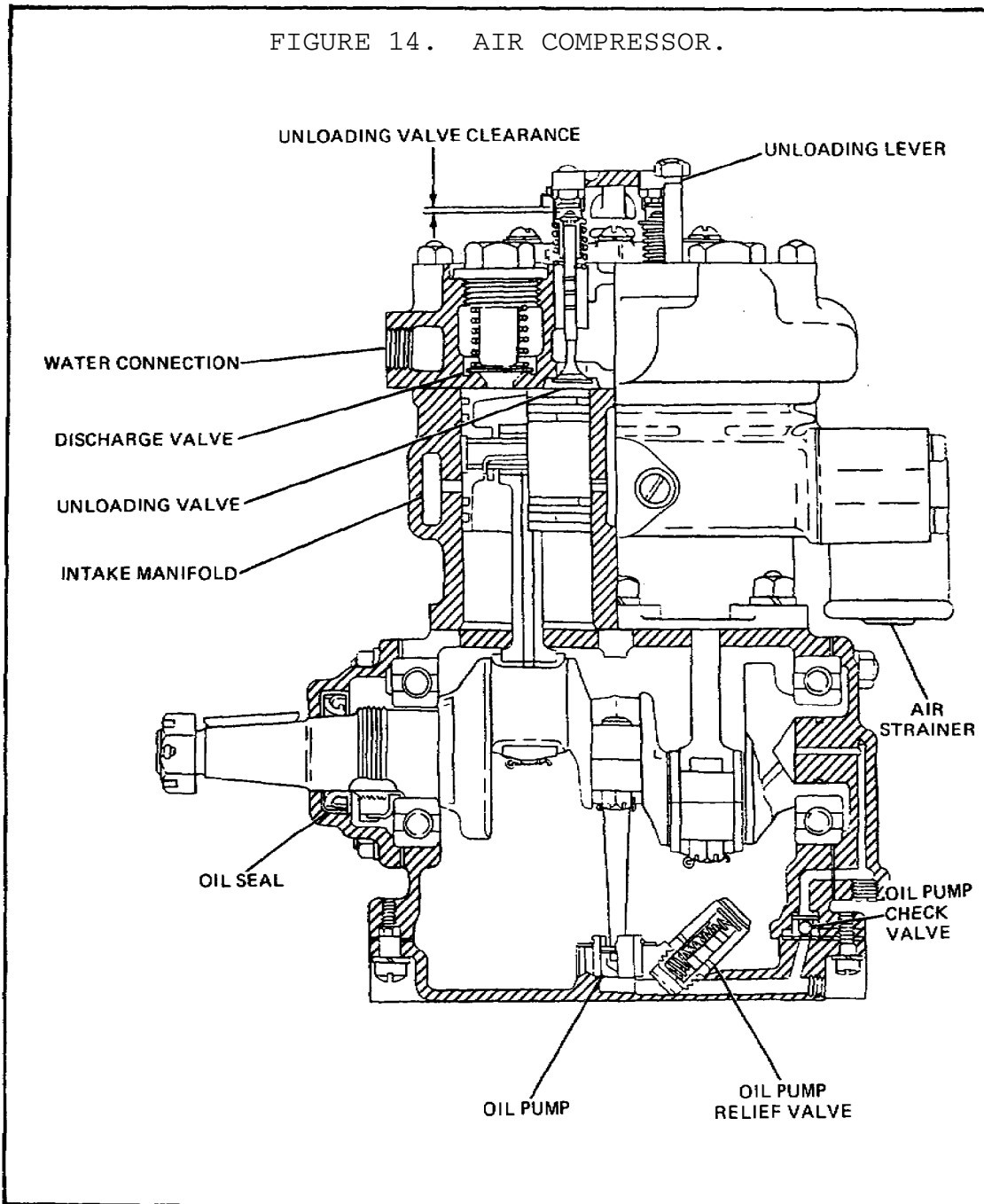

The air compressor pumps up the air pressure needed to operate the air-hydraulic cylinder. The compressor is driven by the vehicle's engine and turns all the time the engine is running.

Lesson 2/Learning Event 1

It is generally belt driven, but on some 5-ton trucks it is gear driven.

The air compressor used on the M809-series vehicle is of the single-action, piston-type, and cooling and lubricating are accomplished by the engine's respective cooling and lubricating systems. The compressor is mounted to the left side of the engine. An unloader valve in the cylinder head vents compressed air when pressure exceeds the predetermined level.

On some compressor models, the lubricating oil is carried from the engine main oil gallery to the compressor by a flexible line. Oil leaking past the compressor bearings drains into the compressor mounting base. A return line connected to the mounting base returns the oil to the engine crankcase.

On other compressor models, lubricating oil is carried to and from the air compressor through passages in the compressor mounting base. The compressor mounting base oil passages align with oil passages in the engine crankcase and the compressor.

The compression of air in the compressor creates so much heat that the compressor must be cooled. Some compressors are air cooled while others are water cooled from the engine's cooling system. Air-cooled compressors have cooling fins around the cylinders and the cylinder head. Water-cooled compressors have water jackets either in the cylinder head or around the cylinders. A water inlet line and a water outlet line connect the compressor water jacket to the engine cooling system.

The compressor has air-check valves, one intake and one exhaust valve for each cylinder. The valves are held closed by light spring tension. In each cylinder the intake valve is opened by the suction created by the cylinder piston on its downward (intake) stroke. The exhaust valve is opened by air, compressed in the cylinder on the piston's upward (exhaust) stroke. An air strainer is mounted over the air compressor air intake port. The air strainer inlet is connected to the engine air intake system.

During the intake stroke of either compressor cylinder, air is drawn through the air strainer and intake valve and into the cylinder. On the exhaust stroke, the air compressed in the cylinder holds the intake valve tightly closed and opens the exhaust valve. The compressed air then flows through the exhaust valve into the compressed air system through an air discharge line connected to the compressor.

An unloading mechanism on the cylinder head unloads compressor compression whenever the air pressure reaches a predetermined maximum. The unloader mechanism generally has a diaphragm connected to linkage, so that when air pressure is applied at one side of the diaphragm, the diaphragm is moved to hold either the unloader valves or the intake valves open. At this time, the compressor will continue to run with the engine but will not compress air. When the air pressure drops to a certain predetermined amount, the pressure is released from the diaphragm, permitting the intake or unloader valves to close and the compressor pumps up the pressure again.

AIR GOVERNOR

The operation of the unloader mechanism is controlled by the air governor. Many different designs of governors are used, but they all serve the same purpose and operate on the same basic principles. Primarily, any air governor is a valve held closed by spring tension. Air pressure from the compressor and air reservoir is applied to a diaphragm, piston, or a similar device that opposes the spring tension in an attempt to open the valve. When the air pressure reaches a desired maximum of about 110 to 120 PSI, air pressure overcomes the spring tension and the governor valve opens. Air pressure flows through the open valve to the unloader mechanism opening the unloader valves. When the air pressure drops to a desired minimum, spring tension on the governor valve overcomes the air pressure closing the valve. This releases the air pressure to the unloader allowing the unloader valves to close.

The air governor is mounted on the engine side of the cowl (firewall). At least two air lines must be connected to a governor: one pressure line from the air supply and one line to the unloader on the compressor. A third line, for the pressure exhaust may be connected between the governor and the vehicle vent system. The governor contains a filter to strain the air that passes through it. Most governors have an external adjustment that allows the mechanic to change the tension on the spring holding the air valve closed, which will in turn change the amount of air pressure required to open the governor.

AIR RESERVOIR

Two round steel tanks are used on each truck to hold a supply of compressed air. The tanks are large enough to provide enough air under pressure for several brake applications after the engine has stopped running. The reservoirs also provide a place to trap condensed oil and water vapors. The air, which is heated during compression, is cooled in the tanks causing any vapors in the air to condense. A drain cock is provided in the bottom of each reservoir to drain trapped condensation.

SAFETY VALVE

A relief valve, known as the safety valve, is installed on one of the reservoirs. It is used to prevent air pressure in the system from building up above a safe operating pressure if the governor or unloader mechanism should fail. The valve is held closed by spring pressure and opened by air pressure. When the air pressure in the reservoir exceeds 150 PSI, the valve opens exhausting the excess pressure.

WARNING SIGNAL BUZZER

An electrically operated buzzer is located under the dash panel to warn the vehicle operator if the air pressure falls below a safe operating level. The buzzer sounds when an air-operated switch closes to connect an electrical circuit between the buzzer and the vehicle batteries. The switch is generally mounted under the dash panel near the buzzer and is connected to an air line from the air reservoir. Air pressure on a piston in the switch tends to open the switch contacts, while spring pressure tends to close the switch contacts. When the air pressure falls below 60 PSI, spring pressure closes the switch and the buzzer sounds.

PRESSURE GAGE

An air pressure gage is located on the dash panel to show the amount of pressure in the air system. The gage is made to read pressures from 0 to 120 PSI.

HAND CONTROL VALVE

Some trucks have a hand control valve mounted on the steering column for individual control of the brakes on towed vehicles. Two air lines are connected to the valve: One is a supply line from the truck's air reservoir, and the other is a control line that is attached to the brakes of the trailer. A third threaded air opening in the valve is an air exhaust outlet which is left open.

The hand control valve assembly has an inlet and an exhaust valve mounted on one stem. The valve is normally held in the exhaust position by the intake and exhaust valve spring. One type of hand control valve has a movable exhaust tube that is pushed upward by an exhaust tube spring and downward by a cam plate spring. A hand lever on the control valve is used to rotate a cam changing the tension on the cam plate spring.

With the hand lever in the released position, the exhaust tube spring holds the exhaust tube up. Any air pressure in the trailer brake control line is exhausted through the exhaust tube and outlet on the control valve. Pulling the hand lever to the applied position increases the cam plate spring tension on top of the exhaust tube. This moves the exhaust tube down, first contacting the exhaust valve and blocking the air exhaust passage through the tube. Then it moves the air exhaust and inlet valve assembly down, pushing the air inlet valve off its seat. Air supply pressure flows past the open inlet valve into the control line to apply the trailer brakes. The control air pressure also pushes upward on the exhaust tube tending to lift it and close the inlet valve. When the pressures above and below the tube are equal, the inlet valve closes. By changing the position of the hand lever, the amount of spring tension pushing the exhaust tube down will change, and the driver can regulate the amount of control line pressure.

TRAILER COUPLING HOSES AND CONNECTORS

Two air outlets are provided at the rear of the truck for connecting its brake system to the trailer brakes. One outlet contains a tag with the word "EMERGENCY" printed on it; the second outlet has a tag with the label "SERVICE." Two air line connections on the trailer also have emergency and service tags. When connecting the two brake systems together, the emergency line on the truck must be connected to the emergency line on the trailer. Likewise, the service lines must be connected together. The service line connects the air control line of the truck to the control line of the trailer to control the normal application of the brakes. The emergency line connects the air supply of the truck to the emergency relay valve of the trailer. If the emergency line should break or be disconnected, the trailer brakes automatically apply.

An air shutoff cock is located at each trailer connection outlet on the truck. The cocks must be turned off to prevent the loss of air when the truck brake system is not connected to a trailer brake system.

Lesson 2/Learning Event 1

A quick disconnect air hose coupling assembly is installed on the air line connections of both the trailer and the truck. The coupling assembly contains a lockpin and a replaceable body washer. When the trailer connections are not being used, a dummy coupling is installed on the air hose coupling assemblies to keep dirt and water out of the coupling.

Flexible high-pressure hoses are used to connect the air coupling assemblies on the truck and trailer together. Hose coupling assemblies that interlock with the couplings on the vehicles are installed on the ends of the hoses.

EMERGENCY RELAY VALVE

Trailers that are equipped with their own air reservoir have an emergency relay valve. This valve is mounted near the trailer's air reservoir and air-over-hydraulic cylinder. It consists of a relay section and an emergency section which work together to control the action of the air-over-hydraulic cylinder and wheel brakes.

In normal operation, the emergency relay valve serves as a relay station. It receives air pressure control signals from the truck brake system and relays them to the trailer brakes. Instead of using air pressure directly from the truck to apply the trailer brakes, the valve uses air from the trailer air reservoir. When the brakes are released, the applied pressure is released through an exhaust port on the emergency relay valve. The relaying action of the valve speeds up the action of the brakes.

In addition to the above, the emergency relay valve controls the flow of air from the truck reservoir into the trailer reservoir. Since the trailer does not have an air compressor, it must depend on the truck's compressed air system to keep its air reservoir pumped up.

The emergency relay valve also directs air pressure to the air-over-hydraulic cylinder to automatically apply the trailer brakes if the trailer breaks away from the truck or if there is a serious leak in the emergency line.

The emergency relay valve has two main body sections separated by a relay valve diaphragm. It contains three internal valves and a number of air passages. Threaded openings are provided for connections to the emergency air line, service air line, air reservoir, and air-over-hydraulic cylinder. The exhaust opening is also threaded. A drain plug is usually provided in the bottom of the assembly for draining condensation.

AIR-OVER-HYDRAULIC CYLINDER

The air-over-hydraulic cylinder assembly of a trailer consists of a brake air chamber and hydraulic master cylinder. The master cylinder is like any typical hydraulic brake master cylinder and is used to force fluid under pressure to the wheel cylinders in the wheel brakes. The brake air chamber changes air pressure into mechanical motion to operate the master cylinder. On tandem-axle trailers an air-over-hydraulic cylinder may be used on each axle.

The brake air chamber contains a diaphragm secured between the outer edges of the body and cover. The diaphragm is airtight and divides the chamber into pressure and non-pressure sides. The pressure side of the chamber has a threaded opening for connecting the brake apply air line. The nonpressure side is vented to the outside air. A compression spring in the nonpressure side holds a pushrod against the diaphragm, and returns both the diaphragm and pushrod to the pressure side of the chamber. One end of the pushrod extends from the nonpressure side of the chamber.

The master cylinder is mounted on the brake air chamber so that the pushrod aligns with the master cylinder piston. When compressed air enters the pressure side of the brake chamber, the diaphragm moves toward the nonpressure side. This extends the pushrod, moving the master cylinder piston, and forcing brake fluid to the wheel cylinders to apply the brakes. When the compressed air in the chamber is released, the compression spring returns the pushrod and diaphragm to the pressure side of the chamber allowing the brakes to release.

Learning Event 2:

DESCRIBE THE OPERATION OF THE AIR-HYDRAULIC BRAKE SYSTEM

5-TON, 6X6 TRUCKS

Now that you are familiar with the components that make up air-hydraulic brake systems, let's see how they work together to stop a vehicle. First, let's consider a truck that is not connected to a trailer. We will use the brake system of the 5-ton, 6x6 truck for our discussion.

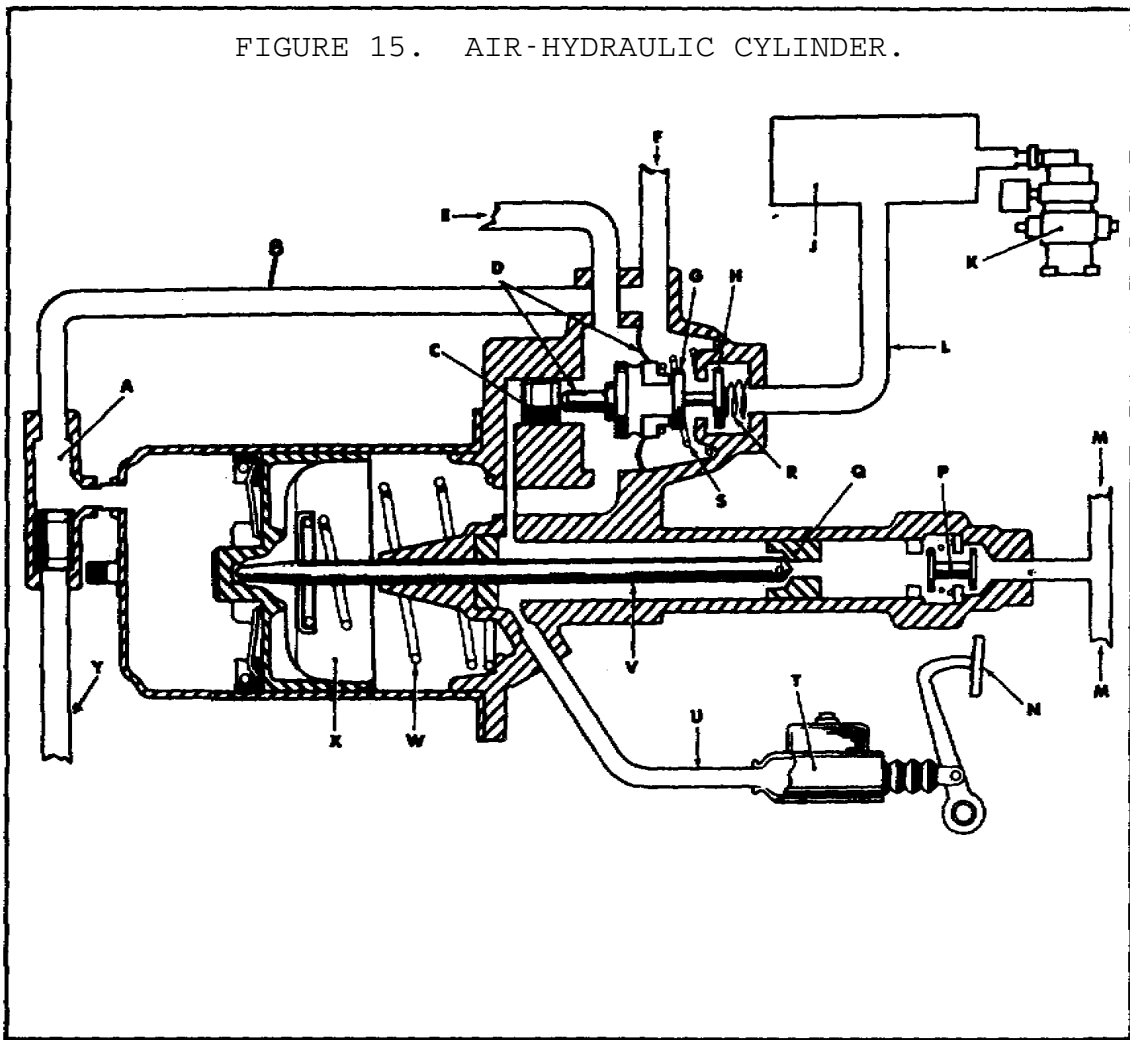

A	Double-check valve assembly	N	Brake pedal
B	Air control line	P	Residual line check valve assembly
C	Relay piston	Q	Hydraulic piston
D	Diaphragm assembly	R	Poppet return spring
E	Exhaust port	S	Diaphragm return spring
F	Trailer connection	T	Master cylinder
G	Atmospheric poppet closed	U	Hydraulic inlet line
H	Air pressure poppet open	V	Pushrod
J	Compressed air reservoir	W	Piston return spring
K	Air compressor	X	Power piston
L	Compressed air inlet line	Y	Trailer connection
M	Hydraulic outlet port		

When the brake pedal is pushed down, brake fluid is pushed through the hydraulic system. The fluid pressure is transmitted from the slave cylinder to the relay piston in the control unit. The relay piston changes the hydraulic pressure to mechanical motion, which pushes the diaphragm assembly against the atmospheric poppet to close the air exhaust passage and to open the air pressure poppet.

Compressed air can now flow from the reservoir, through the compressed air line, and past the open air pressure poppet in the control unit. The air-flow is directed into two control lines leaving the control unit. One line is to the service outlet to control the trailer brakes. The other control line carries the air pressure to the power cylinder of the air-hydraulic cylinder. The air pressure forces the power piston and the attached pushrod toward the slave cylinder.

The extending pushrod contacts the slave cylinder hydraulic piston and pushes it forward. This closes the check valve in the hydraulic piston and brake fluid under pressure is forced through the outlet to the wheel cylinder to apply the brakes. The fluid pressure to the wheel brakes is now being produced from two sources. The air pressure that is pushing the power piston ahead is one source. The second source is from the pressure applied on the brake pedal. Hydraulic pressure from the master cylinder pushes on the slave cylinder piston, along with the pushrod, so the two forces add together.

The amount of air pressure permitted to enter the power cylinder is regulated by the pressure applied to the brake pedal. To see how this is possible, assume that the driver applies enough pressure on the brake pedal to slow the truck down but not enough to lock the wheels.

Lesson 2/Learning Event 2

The air pressure that is permitted to enter the control unit pushes on the diaphragm assembly in an attempt to close the air inlet poppet valve. Recall that hydraulic pressure from the master cylinder on the relay piston opened the air inlet poppet. Therefore, the air pressure against the diaphragm assembly is opposing the hydraulic pressure on the relay piston. When the air pressure reaches a point where it overcomes the hydraulic pressure, the diaphragm assembly and relay valve move slightly allowing the air inlet poppet to close shutting off incoming air. But the atmospheric poppet remains closed so the controlled air pressure is trapped in the power cylinder. This is known as the "holding" or "lap" position.

The air-hydraulic cylinder will remain in the holding position maintaining an unchanging amount of controlled air pressure as long as the same amount of foot pressure is applied to the brake pedal. The amount of brake application is determined by the amount of controlled air pressure trapped in the power cylinder. If more foot pressure is applied on the brake pedal, more hydraulic pressure is applied on the relay piston. This opens the air inlet poppet and the controlled air pressure increases until it is great enough to overcome the increased hydraulic pressure and move the relay piston back allowing the air inlet poppet to close.

When the brake pedal is released, hydraulic pressure on the relay piston is removed. This allows the diaphragm return spring to return the diaphragm assembly to the released position opening the atmospheric poppet. The control pressure is released to the outside air by passing through the drilled center of the diaphragm assembly and the exhaust port. The piston return spring returns the power piston, pushrod, and hydraulic piston to the released position. As the hydraulic piston nears the released position, the check valve in the center of the piston opens.

The residual check valve assembly in the outlet of the slave cylinder maintains a slight pressure in the lines and wheel cylinders, just as the master cylinder check valve does in straight hydraulic brakes.

To operate properly, the air-hydraulic cylinder must have a supply of compressed air. But if the air supply should fail, the vehicle brakes will still be applied when the brake pedal is pressed. Brake fluid from the master cylinder will flow through the check valve in the center of the slave cylinder hydraulic piston to the wheel brakes. There will be no boost from the air-power cylinder, but the vehicle could be operated under emergency conditions.

Lesson 2/Learning Event 2

Now let's discuss the complete compressed air system of the 5-ton, 6x6 truck. The truck has service and emergency trailer couplings at the front as well as at the rear. If a truck must be towed, the trailer couplings at the front can be connected to the rear trailer couplings of the towing truck. With the two brake systems connected in this manner, the brakes of both trucks can be controlled from the towing truck. Three double-check valves direct the flow of controlled air pressure.

One double-check valve is located at the control line connection of the air-hydraulic cylinder. The center connection of the valve is connected to the power cylinder. The control line from the air-hydraulic cylinder control valve is connected to an end connection of the double-check valve. The control or service line from the front of the truck is attached to the remaining end connection of the double-check valve.

When the control unit of the air-hydraulic cylinder sends air pressure to the double-check valve, the air pressure moves a sliding piston in the valve closing the service line passage to the front of the truck. The air can move freely from the control unit, through the double-check valve, into the power cylinder to apply the brakes.

When the truck is being towed and the brakes are applied, the double-check valve prevents the escape of controlled air from the towing truck. Brake air controlled pressure from the tow truck flows through the service line to the double-check valve. The controlled air moves the sliding piston closing the passage to the air-hydraulic control unit. Controlled air pressure now flows freely from the tow truck, through the double-check valve, and into the power cylinder.

The two remaining double-check valves direct the controlled air flowing to the trailer service coupling at the rear of the truck. They are connected so that controlled pressure furnished from one control unit cannot flow to another control unit. This must be done to prevent the escape of controlled pressure. For instance, if controlled pressure from the air-hydraulic cylinder is allowed to flow through the control lines to the hand control valve, the pressure will be released through the open-hand control exhaust valve.

The double-check valves used on the 5-ton truck make it possible for the brakes of a towed vehicle to be applied by using either the brake pedal or the hand control of the towing truck. When the brake pedal is pushed down, the brakes of both the towing and the towed vehicle are applied. When the hand control valve is applied, the double-check valves direct the controlled air so only the brakes of the towed vehicle are applied.

2 1/2-TON-SERIES TRUCKS

The principles of operation of the air-hydraulic brakes of the 5-ton, 6x6 trucks can be applied to the air-hydraulic brakes of the 2 1/2-ton-series trucks. However, there is enough difference in the design of the two brake systems so that a short discussion on the 2 1/2-ton truck brakes is needed.

The air-hydraulic cylinder of a 2 1/2-ton truck looks different from that of a 5-ton truck, but the operation is about the same. Brake fluid applied pressure from the master cylinder is transmitted to the slave cylinder and the fluid passage at one end of the hydraulic control valve piston. The control valve piston then pushes on the slave cylinder compensator piston moving it to close the air exhaust valve and open the air inlet valve. Air pressure from the reservoir flows through the air inlet opening and out one control line to the power cylinder and a second control line to the trailer service coupling.

Air pressure on the compensator piston and hydraulic pressure on the control valve piston oppose each other to regulate the controlled air pressure. When the brake pedal is released, hydraulic pressure is removed from the control valve piston and the compensator piston spring returns the compensator piston and control valve to the released position. This allows the air inlet valve to close and opens the air exhaust valve. Controlled pressure is exhausted through the hollow compensator piston and out the air breather port.

The power cylinder and hydraulic slave cylinder work just like the power and slave cylinders on the 5-ton truck with two exceptions. The hydraulic piston is returned by inner and outer slave cylinder piston springs. There is no residual line pressure check valve in the outlet of the 2 1/2-ton truck's slave cylinder like on the 5-ton truck. The 2 1/2-ton M35-series truck has the residual line pressure check valve in the outlet of the master cylinder.

The M35-series cargo trucks do not have a hand control valve or trailer couplings at the front of the truck as the 5-ton truck does. However, they do have service and emergency trailer couplings at the rear of the truck. The 2 1/2-ton tractor trucks have a hand control valve so the trailer brakes can be operated separately.

TRAILERS

Several different applications of air-over-hydraulic brake systems are used on trailers, but they can be broken down into two general types--brake systems with automatic breakaway protection, and brake systems that do not have breakaway protection.

Trailer air-over-hydraulic brake systems that do not have breakaway protection have only one air hose coupling which must be connected to the service trailer coupling on the truck. When either the brake foot pedal or the hand control valve on the truck is applied, brake controlled air pressure flows through the service air line to the trailer.

On the trailer, the air line carries the controlled air to an air filter and then to the brake air chamber. The brake air chamber changes the air pressure to the mechanical motion needed to work the hydraulic master cylinder. As the air chamber pushrod moves the master cylinder piston, brake fluid is forced into the wheel cylinders to apply the wheel brakes.

When the brakes are released by the driver, air pressure in the trailer brake air chamber flows back to the truck through the service line and is exhausted through the hand control valve or the air-hydraulic cylinder control unit.

Trailers with automatic breakaway protection have an emergency air hose coupling, emergency relay valve, and an air reservoir plus all the parts used on trailer brake systems without breakaway protection. The action of this brake system is controlled by the emergency relay valve. Let's discuss its operation.

With the air hose couplings connected to the truck and the air shutoff cocks open, compressed air from the truck reservoirs flows through the emergency line to the supply air inlet opening of the emergency relay valve. The air flows through the check valve in the center of the emergency valve diaphragm, through the air supply passage, and out the reservoir line opening to the trailer reservoir. The airflow continues until the pressure in the trailer reservoir is equal to the pressure in the truck reservoir. Under these conditions the air pressure above and below the emergency diaphragm is equal, so the emergency diaphragm spring holds the diaphragm in the raised position.

Lesson 2/Learning Event 2

When the truck driver applies the brakes, controlled air from the truck flows through the service line to the control line inlet at the top of the emergency relay valve. An internal passage carries the controlled pressure to the cavity above the relay valve diaphragm. Because this cavity is small, the controlled air fills it quickly and moves the diaphragm and relay valve plunger down, compressing the relay valve diaphragm spring. The valve plunger closes the exhaust valve and then compresses the valve spring, opening the air inlet valve. Compressed air now flows from the trailer reservoir through the reservoir line opening, past the open air inlet valve, and out the outlet opening to the brake chamber. The brake chamber rod extends working the master cylinder and applying the brakes.

When the driver releases the brakes, controlled line pressure is released from the top of the relay valve diaphragm and the relay valve plunger. The diaphragm spring pushes the relay valve plunger up, opening the exhaust valve and permitting the valve spring to close the air inlet valve. Brake applied air pressure in the brake chamber is released to the open air by passing through the open center of the relay valve plunger to a cavity that is connected to the exhaust port of the emergency relay valve.

The emergency relay valve will maintain an air applied pressure in the brake chamber that corresponds with the air controlled pressure from the truck. This is known as the balanced or holding position and occurs when brake control pressure from the truck pushing down on the relay diaphragm is equal to the upward pressure on the diaphragm. Upward pressure is exerted by the diaphragm spring and brake applied air pressure. The applied pressure is admitted to the bottom side of the relay diaphragm through an internal passage from the air applied passage. When pressures on both sides of the diaphragm are equal, the diaphragm is held in the mid position so that both the air inlet valve and the air exhaust valve are closed, which maintains a definite amount of brake applied air pressure. If controlled pressure is increased, it pushes the valve plunger down opening the air inlet valve to increase applied pressure. If controlled pressure is decreased, the valve plunger moves up exhausting some applied pressure.

Now let's see how the emergency relay valve provides automatic breakaway protection. Since the emergency air line is connected to the air supply inlet opening, air pressure from the truck reservoir is present on the bottom side of the emergency valve diaphragm. Air pressure from the trailer reservoir is present on the top side of the emergency valve diaphragm from the air supply passage and the reservoir line inlet opening. Air can pass from the truck reservoir to the trailer reservoir through the one-way check valve in the emergency valve diaphragm, so that during normal operation the air pressure above and below the diaphragm is equal. At this time the emergency valve diaphragm release spring will hold the diaphragm in the raised position.

Assume that there is a loss of air pressure in the emergency line. This could be caused by the trailer breaking away from the truck and breaking the line or by a leaking or disconnected emergency air hose coupling. This removes the air pressure on the bottom side of the emergency valve diaphragm. Air pressure from the trailer reservoir on top of the diaphragm pushes the diaphragm down compressing the diaphragm release spring. The downward movement is transferred to the relay valve plunger, closing the air exhaust valve and opening the air inlet valve allowing compressed air to flow from the reservoir to the brake chamber locking the brakes.

The relay valve plunger will remain in the applied position as long as there is air pressure in the trailer reservoir or until the service line is reconnected to a truck. To release the trailer brakes without connecting the trailer to a truck, the drain cock in the bottom of the reservoir should be opened to allow all the compressed air in the system to escape.

Learning Event 3:

DESCRIBE INSPECTION PROCEDURES FOR THE AIR-HYDRAULIC BRAKE SYSTEM

INTRODUCTION

Maintenance of air-hydraulic brake systems is much the same as that for straight hydraulic brake systems. The major difference between the two is that the air-hydraulic system contains components for compressing air and applying air pressure to the hydraulic system.

As with any other automotive system, a well-organized sequence of events must take place to properly maintain air-hydraulic braking systems. The steps to take include a preroad test inspection, a road test, and an after-road test inspection to determine if there are any troubles, a troubleshooting step to determine the cause of any failure, and then the service and repair required to correct the failures.

The maintenance procedures between 2 1/2- and 5-ton military vehicle braking systems will not vary too much. Therefore, throughout this lesson, general maintenance practices will pertain to all air-hydraulic brake systems unless specific exceptions are discussed.

BEFORE ROAD-TEST INSPECTION

Many times a good visual inspection is all that is needed to locate a brake failure. However, to ensure that all parts of a braking system are working properly, a complete inspection should be made.

The best place to start a visual inspection is at the brake pedal. Check to ensure the pedal does not bind and that it operates the linkage correctly. When the pedal is released, spring tension should return it to its released stop position. Check to ensure there is enough free travel in the pedal movement to allow the brakes to completely release when the pedal is released. Check for wear on the pedal bushing. The pedal should move freely but not have any sideways motion. Check the pedal travel for sponginess which would indicate air in the hydraulic system.

Inspect the master cylinder next. Check the fluid level and correct it if necessary. Using the proper tools, check all the mounting bolts to see if they are tight. Check the cylinder for leaks in the housing, around the dust boot, and at all fittings where lines are connected. Ensure the reservoir vent operates properly.

Next, follow the hydraulic line from the master cylinder to the air-hydraulic cylinder. Check for breaks, kinks, and leaking connections. Inspect the air-hydraulic cylinder mounting bolts for tightness and the cylinder for dents. Check for leaks at all connections.

Follow the hydraulic lines from the air-hydraulic cylinder to the tees at the front and rear axles and on to each wheel cylinder. Check all lines for leaks, kinks, and cracks. Ensure the lines are supported properly to the frame or axle. Check each flexible line for leaks and frayed material.

Inspect the backing plate and lower drum area of each wheel for an indication of brake fluid. Leaking wheel cylinders will leave traces of fluid that can often be seen without pulling the wheel and brake drum. This type of leak will soak the brake lining and cause a brake to grab. While at the wheels, check each one for secure lugs and nuts.

Next check the air compressing system. Be sure the compressor is mounted securely and the air breather is clean. Inspect drive belts (where applicable) for proper tightness and condition. Worn, frayed, or glazed belts can cause trouble. Check the condition of all air lines and connections from the compressor to the governor, pressure gage, buzzer system, air tanks, air-hydraulic cylinder, and for tightness at connections. Check the air tanks for secure mounting and condition. Open the petcocks to be sure all moisture has been drained and then close them again.

ROAD-TEST INSPECTION

To determine exactly how well a brake system is operating, the vehicle must have its trailer connected and be road-tested. This includes the checks made prior to moving the vehicle, while the vehicle is in motion, and after the road test is finished.

Start the engine and adjust the throttle so that it runs at about 1,000 RPM. While the engine is warming up, the following steps should be performed:

- Ensure the warning buzzer operates until the air pressure builds up to about 60 PSI (105 PSI for M809-series vehicles).
- Watch the air pressure gage and notice whether or not the air pressure builds up steadily.

Lesson 2/Learning Event 3

- Check to see that the governor operates when the pressure reaches about 105 PSI. (If the governor does not stop the pressure from building up over 105 to 120 PSI, the engine must be shut off and the system repaired.)
- Operate the brake pedal several times. Check the action of the pedal by its feel. You should be able to tell if the brakes are applying.
- Pump the brakes until the air pressure drops to about 80 to 105 PSI. At this time the governor should start the compressor again and the pressure should build back up to about 105 to 120 PSI and stay there.
- When the pressure has reached 105 to 120 PSI, turn the engine off and watch the pressure gage. If the pressure drops enough in one minute so that you can notice it on the gage, it indicates there is a leak in the system that must be corrected.

The road test part of the inspection is made to determine how well the working parts of the brake system are operating. When making a road test, the vehicle trailer should be connected to the truck so that the entire braking system can be tested. Test the operation of the brakes several times. This should be done at various speeds from 20 to 40 MPH. Try slowing the vehicle and bringing it to a complete stop. Check to see if--

- Excessive pressure is required on the brake pedal to stop the vehicle.
- The brake pedal must be pressed down near the floorboard before the brakes hold.
- The vehicle pulls to one side when braking.
- The vehicle comes up to the proper speed.
- One or more brakes lock when braking rapidly.
- There is any unusual noise or chatter when the brakes are applied.

AFTER ROAD-TEST INSPECTION

This inspection is made to see if anything unusual happened during the road test.

Check the temperature of the brake drums on the truck and trailer. They should be warm but not very hot.

Check to see if there is any indication of new brake fluid leaks.

Check the trailer brake air line connections for leaks.

TROUBLESHOOTING

After completing an inspection and road test of a vehicle braking system, you should have a pretty good idea of what the system is doing wrong. The next thing to do is to find out what is making the system do something wrong. This is known as troubleshooting and consists of isolating or locating the part or parts that are causing the trouble. We will refer to the major trouble as a malfunction and discuss several things that could cause each malfunction as well as what should be done to correct the trouble.

Insufficient Brakes

You will sometimes find a braking system that will not press the brake linings against the drums hard enough to stop the vehicle in the proper distance.

Check the wheel brake lining condition and adjustment. If the linings are worn badly, they should be replaced. If they are too far from the brake drums, they should be adjusted.

Check the air pressure system to ensure there is a minimum of 80 to 105 PSI. Correct any leaks and replace components that are not working.

Check the air-hydraulic cylinder for proper operation. Certain tests (which we will discuss later) can be made to determine if this component is doing its job.

Lesson 2/Learning Event 3

Brakes Apply Too Slowly

If you depress the brake pedal and the braking action does not occur immediately, it indicates there is a bind or weakness some place.

First, ensure you have sufficient air pressure and there is no water (condensation) in the compressed air system.

Check all air and hydraulic lines to ensure they are not kinked or bent to a point where they will restrict the flow of air or hydraulic fluid.

Check the brake shoes at their anchors. They should move freely and not bind.

Brakes Dragging

This malfunction is noticeable when you are road-testing a vehicle. The vehicle holds back when you are trying to accelerate, and when you disengage the clutch, the truck will not coast freely.

First, check the brake pedal free play adjustment to ensure you have the proper clearance. If the pedal does not allow the master cylinder piston and primary cup to clear the compensating port, the brake fluid cannot come back to the master cylinder reservoir from the wheel cylinders.

Next, check the brake adjustment of each wheel to ensure there is enough clearance when the brakes are released.

Restricted air and hydraulic lines can also prevent the brakes from releasing.

Ensure the brake shoes are not sticking on the anchor pins.

Check the master cylinder for operation. If some foreign material, such as oil or dirt, is mixed with the brake fluid in the reservoir, it can plug the ports or warp the rubber cups. This will prevent the fluid from returning to the reservoir.

Sticking pistons in the wheel cylinders can also cause dragging brakes. If the pistons or cylinders are corroded, the cylinder assemblies should be replaced.

As a last resort, check the operation of the air-hydraulic cylinder. It is possible that the air valve is not allowing the compressed air in the cylinder to escape. If tests indicate improper operation, the air-hydraulic cylinder should be replaced.

Brakes Grab

This malfunction is most noticeable when you first apply the brakes. As soon as the brakes are applied, the wheels tend to lock and the tires slide on the road. Sometimes only one wheel will grab, while at other times more than one will grab.

Grease, fluid, or grit on the brake lining is the primary cause of this fault. With this condition the lining must be replaced.

If the brake shoes are binding on the anchors, they will snap out to the drums when enough pressure is applied.

Loose spring D-bolts or improperly adjusted wheel bearings can cause the position of the wheel to shift when the brakes are applied.

Loose lining on brake shoes and weak or broken brake shoe return springs will allow the brakes to grab.

Brake drums that are out of round, scored, or cracked can also cause brakes to lock up.

Noisy Brakes

Squealing or grinding noises when the brakes are applied are not normal.

Glazed lining that makes the brakes squeal should be replaced.

Scored brake drums and linings that are worn down to the rivets or shoes will cause a grinding noise.

If the brake shoes, backing plates, or anchor pins are bent or warped, the brakes will make an unusual sound when applied.

This page intentionally left blank.

PRACTICE EXERCISE

1. What supplies the initial brake hydraulic pressure?
 - a. Master cylinder
 - b. Power cylinder
 - c. Slave cylinder

2. What changes air pressure to mechanical motions
 - a. Master cylinder
 - b. Power cylinder
 - c. Wheel cylinder

3. A "spongy" feel on the brake pedal indicates
 - a. improperly adjusted linkage.
 - b. air in the hydraulic system.
 - c. sticking wheel cylinders.

4. What section of the air-hydraulic cylinder uses both air and hydraulic pressure in its operation?
 - a. Control unit
 - b. Power cylinder
 - c. Slave cylinder

5. What compressed air system component is electrically operated?
 - a. Safety valve
 - b. Pressure gage
 - c. Warning signal

Lesson 2

ANSWERS TO PRACTICE EXERCISE

1. a (page 39)

2. b (page 47)

3. b (page 56)

4. a (page 49)

5. c (page 44)

LESSON 3
AIR-BRAKE SYSTEMS

TASK

Describe the principles, construction, and operation of straight air-brake systems.

CONDITIONS

Given information on the components and operation of straight air-brake systems.

STANDARDS

Answer 70 percent of the multiple-choice test items covering fundamentals of air-brake systems.

REFERENCES

TM 9-8000

Learning Event 1:

DESCRIBE THE COMPONENTS OF THE STRAIGHT AIR-BRAKE SYSTEM

SYSTEM COMPONENTS

Many parts of straight air-brake systems are similar to compressed air system components in air-hydraulic brake systems. Refer to the illustration below of a 6x6 truck air-brake system as the components are discussed.

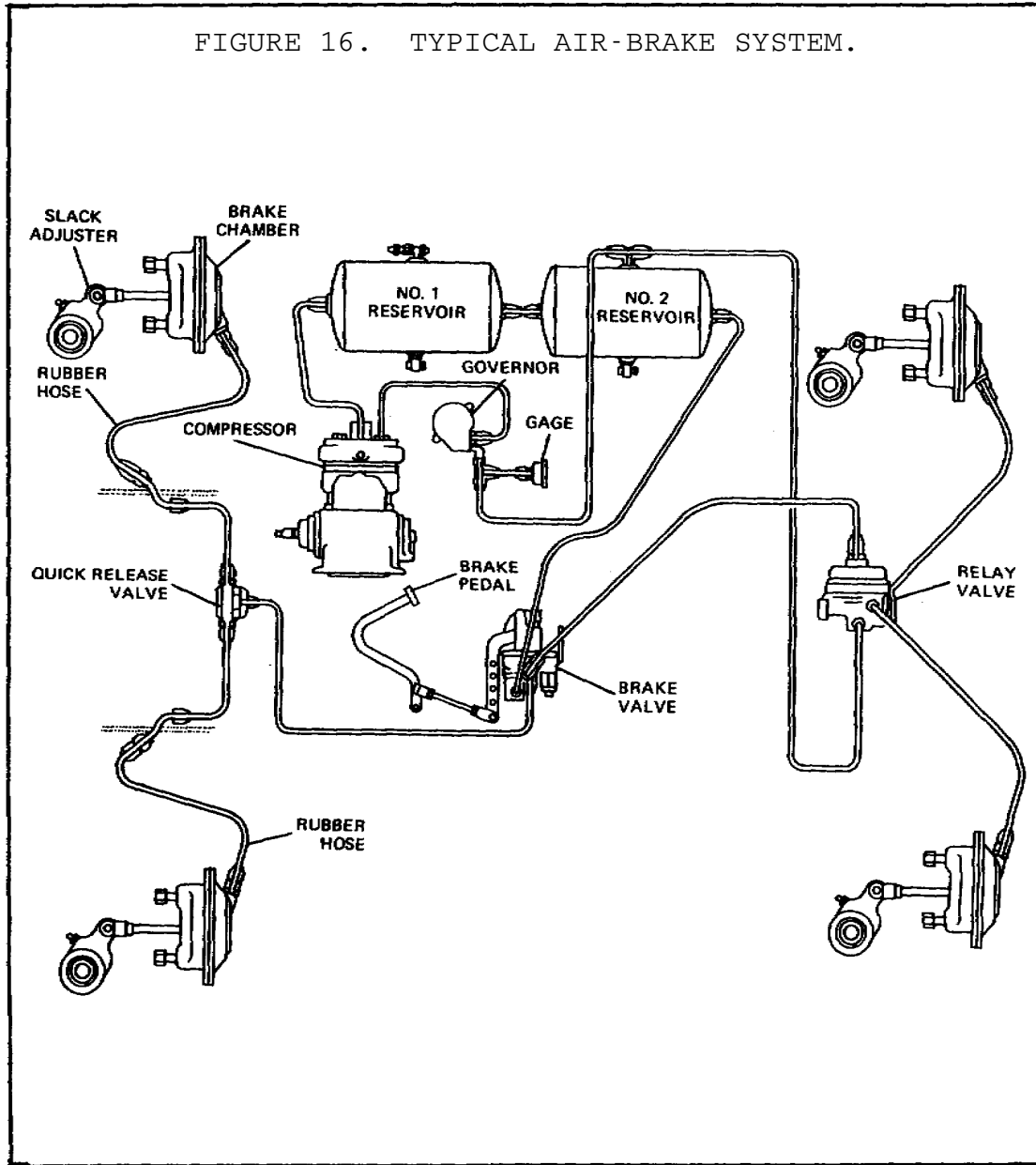

The compressed air system, consisting of the air compressor, governor, and two reservoirs, is about the same as the one we studied for air-hydraulic brake systems. There may be some minor differences in the air compressor and governor, but they will not affect the maintenance practices on the components.

An air line connects the compressed air in the reservoirs to the brake valve. The brake pedal operates the lever on the brake valve. When the brake pedal is depressed, it opens a valve in the brake valve and measures a certain amount of compressed air from the reservoirs to go to the front and rear axles.

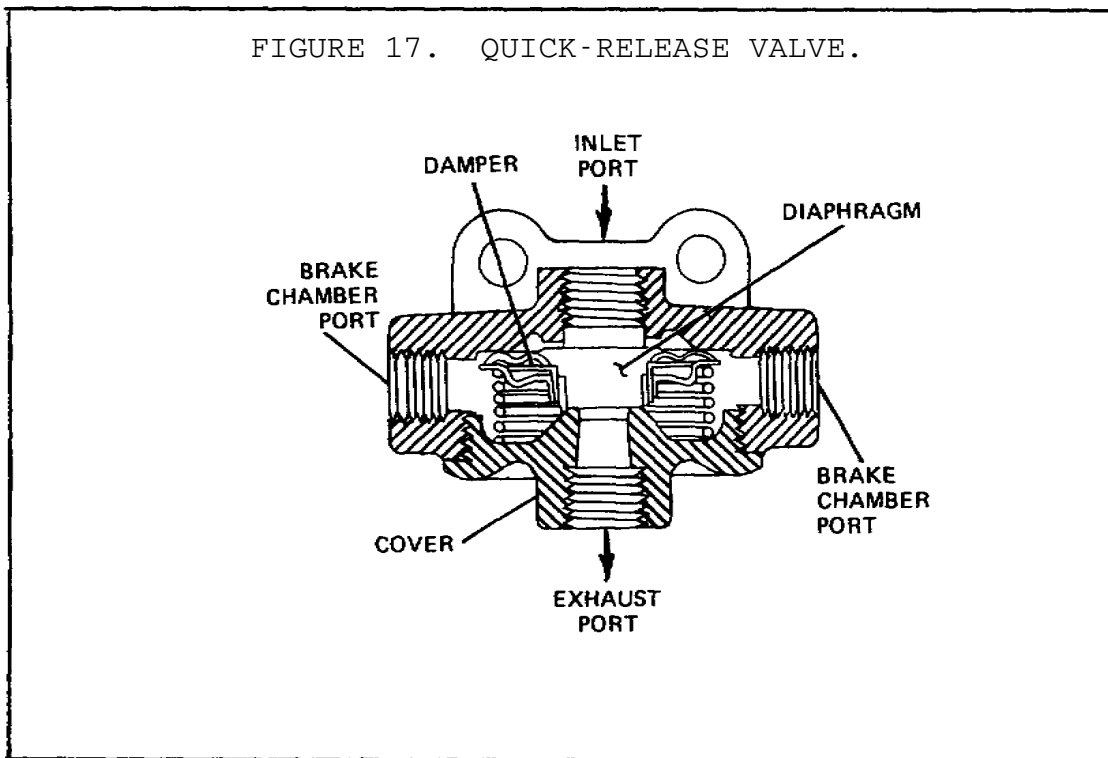

The air line from the brake valve to the front axle goes to a component known as a quick-release valve. When the brakes are applied, the quick-release valve directs compressed air to the right and left front brake chambers. When the pedal is released, the air from the brake chambers escapes out of the quick-release valve and releases the front brakes. The air in the line from the brake valve escapes through the exhaust valve in the brake valve.

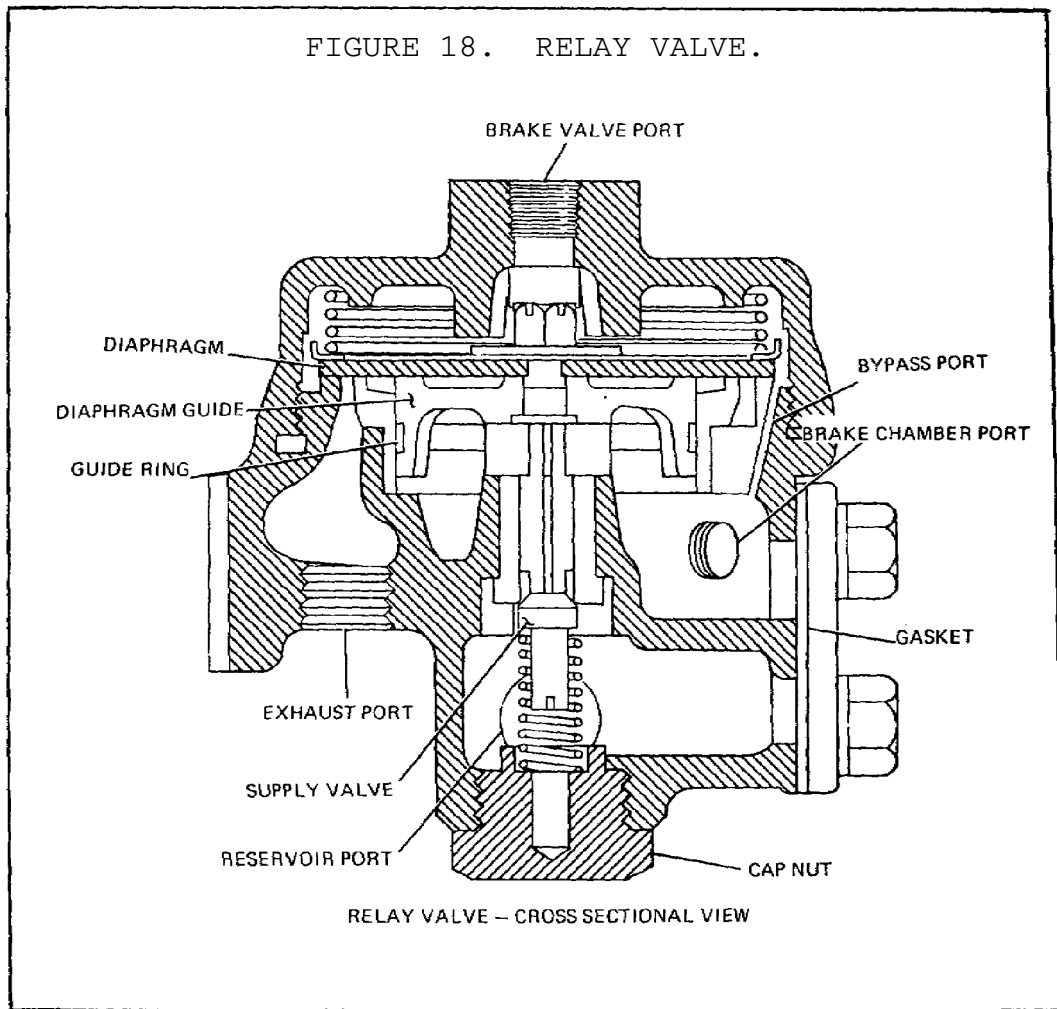

Another air line connects the brake valve to a relay valve at the rear of the vehicle. Normally, this line also contains the stop-light switch. A second air line supplies reservoir air pressure to the relay valve. When the brake pedal is depressed, the brake valve meters a certain amount of air to the relay valve. This air opens a valve in the relay valve and allows a small amount of air from the reservoir to go to each of the brake chambers for the rear wheels. When the brake pedal is released, the air pressure in the line between the brake valve and relay valve is released. This closes the valve in the relay valve shutting off the air supply from the reservoir. At the same time, a quick-release valve in the relay valve opens and allows the air pressure in the brake chambers to escape. This, in turn, releases the rear brakes. The air in the line from the brake valve escapes from the brake valve exhaust valve.

The amount of braking action applied to the truck wheels depends on how far down the brake pedal is depressed. When the pedal is pressed way down, a greater amount of air pressure is applied to the brake chambers. This causes the brake shoes and linings to press harder against the brake drums, providing greater braking action.

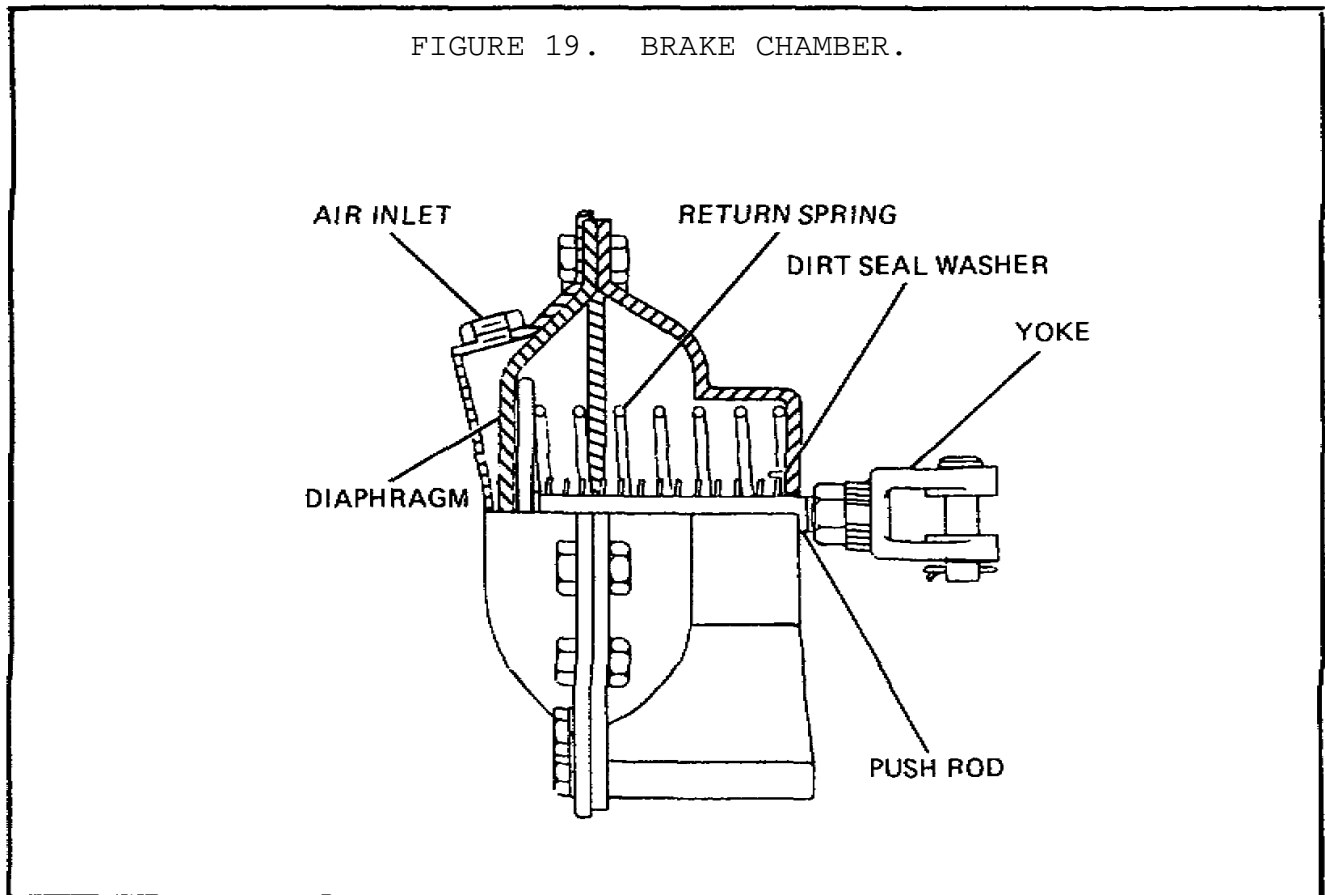

The brake chambers at each wheel convert air pressure to mechanical motion. When air enters the air inlet, it moves the diaphragm which moves the pushrod.

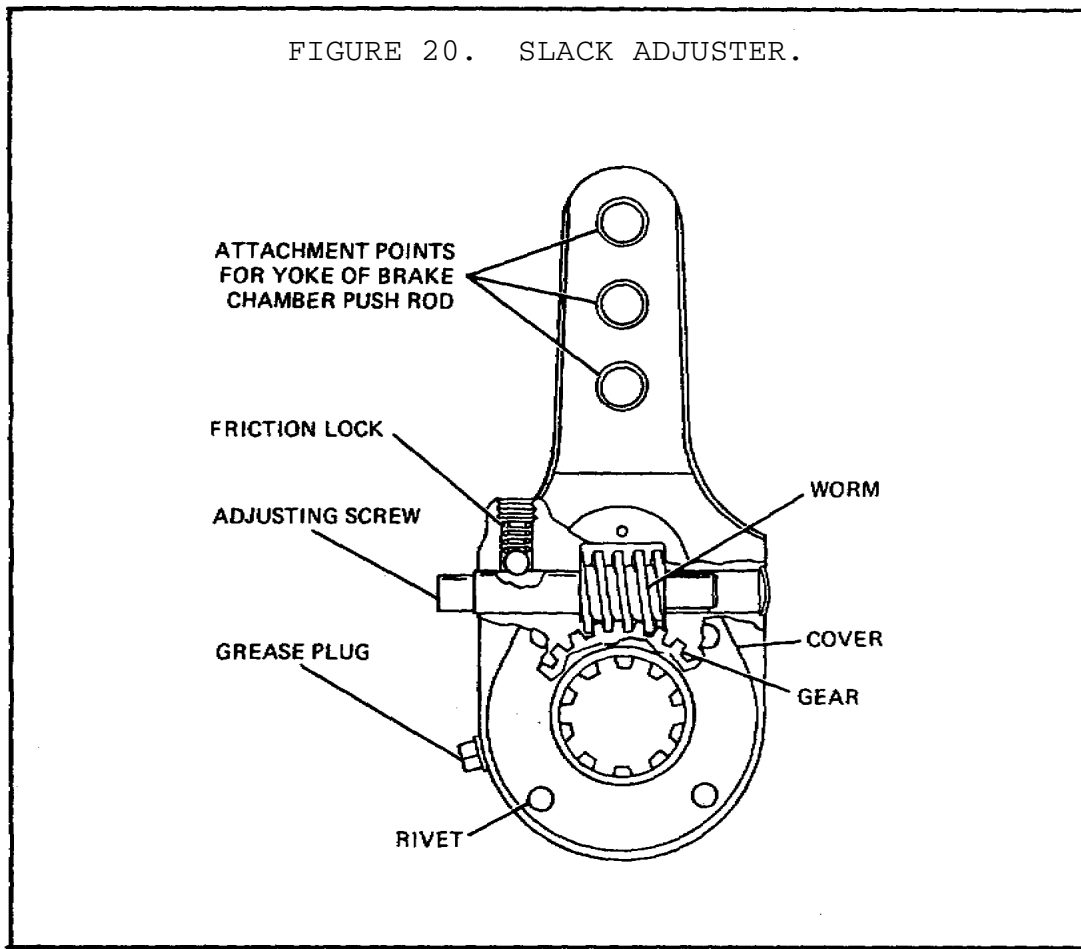

The pushrod of the brake chamber is connected to a slack adjuster. The slack adjuster serves two purposes: to change the back and forth motion of the pushrod to rotary motion and to make minor adjustments to the brake shoes and linings.

The slack adjuster is splined to one end of a shaft that goes through the backing plate of the wheel brake. The other end of the shaft contains a cam. When the brake chamber pushrod moves the end of the slack adjuster, it causes the shaft to rotate. As the cam on the brake end of the shaft rotates, it causes the brake shoes with linings to move against the drum.

Minor adjustment of the brakes is made by rotating the worm shaft on the slack adjuster.

The wheel brake assemblies are much the same as those for hydraulic or air-hydraulic systems. The main difference is the wheel cylinder is replaced with an operating cam.

AUXILIARY COMPONENTS

Some wheeled vehicles require special controls on the braking system.

If we consider a 4x4 truck tractor, for example, we know that its primary job is to pull a semitrailer. Under normal driving conditions when the road is dry, the braking system will work well. When the road is wet and slippery, though, the tractor and trailer will jackknife if the front wheels of the tractor brake too much. To prevent this from happening, the front quick-release valve contains a limiting valve. A two-way valve is also provided to control the limiting valve.

The two-way valve is mounted in the vehicle cab where the operator can reach it easily. The valve has dry and slippery road positions.

An air line connects the valve to the brake valve and another line goes from the two-way valve to the combined limiting and quick-release valve at the front axle.

When the valve is in the dry road position, no air can pass through the two-way valve to the front axle. However, when the valve is in the slippery road position, air from the brake valve passes through the two-way valve and onto the quick-release valve. When this air acts on the limiting device in the quick-release valve, it only allows a small amount of air coming from the brake valve to go to the brake chambers. This will reduce the amount of braking action on the front wheels and prevent the front brakes from locking which would cause the tractor and trailer to jackknife.

Trucks and truck tractors that pull heavy trailer loads must also have a control that will allow the operator to apply the trailer brakes separately from the truck or tractor brakes. This device is known as an independent trailer control valve and is usually mounted on the truck steering column. Notice in the paragraph above that the valve is connected to reservoir air pressure through the manifold fitting for auxiliary devices.

The hand lever on the valve allows the operator to apply line air pressure to the double-check valve at the rear of the vehicle. This valve allows pressure to be applied on the trailer brakes through the trailer service line connection.

Notice that the double-check valve also has a line coming to it from the brake valve. In this way, the trailer brakes can be operated when the truck brakes are applied or they can be applied alone with the use of the trailer control in the cab.

SEMITRAILER AIR-BRAKE SYSTEMS

Most larger trailers equipped with air-brake systems use a service air line and an emergency air line connection to the tractor that tows the trailer. The trailer brake system consists of one or more reservoirs, relay emergency valve, brake chamber and slack adjuster for each wheel, and the connecting air lines.

When the emergency line is connected to the tractor and the connection valve is opened, air will flow from the truck reservoir to the trailer relay valve and into the reservoir. This raises the air pressure at the trailer to the same pressure as that of the truck and holds the quick-release valve in the relay emergency valve open. The compressed air in the trailer reservoir is now available to make the trailer brakes work.

When the truck brake pedal is depressed or the trailer brake control lever is moved, compressed air will move through the service line between the tractor and trailer to the top of the relay emergency valve on the trailer.

The compressed air will close the release valve and open another valve in the relay emergency valve allowing air from the trailer reservoirs to go to each wheel brake chamber on the trailer. This applies the brakes.

When pressure on the service line is released, the air supply from the trailer reservoir to the brake chambers is shut off. At the same time, the quick-release valve in the emergency relay valve is opened so that the air in the brake chambers can escape and release the trailer brakes.

The relay emergency valve is designed to lock the trailer brakes in case the trailer ever breaks away from the tractor. If, for some reason, the emergency air supply line becomes disconnected from the tractor, there will be no air pressure applied where the air enters the relay emergency valve. Without pressure the quick-release valve will close and allow air pressure from the reservoir to go to the brake chambers. This will lock all brakes on the trailer. The brakes will remain locked as long as the air pressure in the trailer reservoir remains high enough. However, as soon as a supply of air is hooked to the emergency line again, the pressure will open the quick-release valve, close off the air supply to the chambers, and the brakes will release. The brakes can also be released by draining the air from the reservoir.

Learning Event 2:

DESCRIBE THE OPERATION OF THE STRAIGHT AIR-BRAKE SYSTEM

OPERATION OF STRAIGHT AIR-BRAKE SYSTEM

So far, we have discussed the components contained in air-brake systems and what they do. Knowledge of how the components function is important so that a mechanic can diagnose troubles without making errors.

As mentioned before, the components of the compressed air system are about the same as those used in 2 1/2- and 5-ton trucks. The operation of air compressors, governors, reservoirs, high-pressure relief valves, and drain cocks of air-brake systems is the same as those discussed in earlier lessons for air-hydraulic systems. Again, in this system, the maximum pressure is about 105 PSI.

The brake valve (or brake application valve) is the device that an operator uses to control pressure to the brakes. It is mounted under the floor of the cab and is controlled by brake pedal movement. It is made so that the driver can vary the air pressure admitted to the brake chambers. As we will see later, the more air pressure there is in the brake chamber, the more the brake shoes will be forced against the brake drum. There are several types of brake valves, but they all do about the same job. The main difference between the types is that some are operated by the foot pedal only, while others are operated by a foot pedal but have a hand-operated limit control. Standard brake valves are fitted with a lever that is connected and operated by a foot pedal.

As the lever is moved toward its fully applied position, mechanical force is applied to the top of the diaphragm in the brake valve. This is done by the action of the plunger and pressure regulating spring assembly. As the diaphragm moves downward, a force is applied to the middle of the rocker arm and onto the inlet and exhaust valve. Because the exhaust valve spring is weaker than the inlet valve spring, the exhaust valve is forced down onto its seat before the inlet valve is forced down to open.

Lesson 3/Learning Event 2

When the inlet valve opens, air pressure flows from the reservoir through the valve to the brake chambers. This applies the brakes. When the air pressure being delivered to the brake chambers, from the opening below the diaphragm, overcomes the mechanical force being applied to the top of the diaphragm, the diaphragm lifts. This permits the inlet valve to close preventing any further rise of air pressure in the brake chambers, while the exhaust valve remains closed and prevents any escape of air pressure.

If the driver pushes the foot pedal farther down, more mechanical force is applied to the top of the diaphragm. When this happens, more pressure is delivered to the brake chamber and is applied to the brakes.

If the driver lets the pedal move toward its released position, the force on top of the diaphragm is reduced. Air pressure below the diaphragm overcomes the mechanical force on top of it, and the diaphragm lifts slightly. When this happens, the inlet valve remains closed and the exhaust valve opens. This exhausts air pressure from the brake chambers until the air pressure below the diaphragm again balances the mechanical force on top of it.

If the driver lets the foot pedal return to the fully released position, the exhaust valve remains open. Thus, all the pressure from the brake chamber is exhausted, and the brakes are fully released.

If the driver pushes the pedal down to the fully applied position, the pressure regulating spring is compressed until the spring guide strikes the spring slat. This holds the rocker arm down, the inlet valve is held open, and full reservoir pressure is allowed to pass through the brake valve to the brake chambers.

The trailer brake control valve is used to apply and release the trailer brakes without applying the brakes of the towing vehicle. This type valve is usually mounted on the steering column or on the instrument panel. The driver may put the handle in any one of several positions between the released and fully applied position.

As the handle of the brake valve is moved toward the applied position, force is applied to the top of the pressure regulating spring. When this happens, the spring and piston assembly move downward and the exhaust valve seat engages the exhaust valve. This closes the passage to the exhaust port. The exhaust and inlet valves, being part of the same assembly, cause both valves to move together. After the exhaust valve is closed and the piston assembly continues to move downward, the inlet valve is forced off its seat. This lets air pressure from the reservoir pass through the inlet valve and out the brake chamber port to the connection leading to the service line and the brakes on the trailer.

As soon as the air pressure below the piston assembly overcomes the mechanical force on top of it, the piston assembly lifts and the intake valve closes. The closing of the inlet valve stops the airflow from the reservoir. The exhaust valve remains closed preventing any loss of air through the exhaust port.

If the brake valve handle is moved farther toward the fully applied position, it adds more mechanical force on top of the piston assembly and increases the delivered air pressure.

If the brake valve handle is moved toward the released position, the mechanical force on top of the piston assembly is decreased. The air pressure below the piston assembly lifts it slightly, opening the exhaust valve and permitting air pressure to exhaust from the service line. When the air pressure under the piston and the mechanical force on top of the piston is again equal, the exhaust valve will close. When the brake valve handle is moved to the released position, the intake valve is closed, the exhaust valve is opened, all air pressure is exhausted from the brake cylinders, and the brakes are released.

Another device in air-brake systems is the quick-release valve. The purpose of this valve, as the name suggests, is to speed up the release of the applied brakes.

When air pressure from the brake valve enters the brake valve port of the valve, the diaphragm moves down and closes the exhaust port. Air pressure then goes around the outer edges of the diaphragm and flows out the side connections (brake chamber ports) to the brake chambers. This applies the brakes.

Lesson 3/Learning Event 2

As soon as the pressure in the brake chamber and connecting lines equals the brake valve pressure above the diaphragm, the force of the spring below the diaphragm forces the outer edge of the diaphragm back up against the body. At the same time, the center of the diaphragm keeps the exhaust port closed. This is the holding position.

If the brake valve pressure on top of the diaphragm is reduced, the brake chamber pressure raises the diaphragm. This opens the exhaust port and lets the brake chamber pressure escape through the exhaust port. If the brake valve pressure on top of the diaphragm is only partially released, the diaphragm goes to the holding position as soon as the pressure above and below it is equal.

As stated earlier, a relay valve is used on the rear wheels of trucks to speed up the application and release of the rear brakes.

When the valve is in the released position, the reservoir pressure is in the cavity below the supply valve which is closed. The diaphragm is in its normal position resting on the diaphragm guide.

When the brake valve is applied, it sends air through the brake valve port into the cavity above the diaphragm. The pressure pushes the diaphragm down. When the diaphragm moves down, its outer edge seals the exhaust port and the center of the diaphragm forces the diaphragm guide and the supply valve down. This opens the supply valve and allows air pressure from the reservoir to flow through the supply valve and into the cavity below the diaphragm. This cavity is connected through the brake chamber port to the brake chambers. With the mechanism in this position, air pressure is flowing directly from the reservoir through the relay valve into the brake chambers applying the brakes.

As soon as the air pressure below the diaphragm equals the air pressure above the diaphragm, the force of the supply valve spring lifts the center of the diaphragm and closes the supply valve. This limits the air pressure being delivered to the brake chambers by the relay valve to the same pressure as that being delivered by the brake valve to the relay valve. In this position, the supply valve is closed and the force of air pressure on top of the diaphragm keeps the outer edge of the diaphragm down sealing the exhaust port. An increase in brake valve pressure repeats the action (as in the applying position) until the two pressures are again equal.

If the brake valve pressure above the diaphragm is reduced, the brake chamber pressure below the diaphragm lifts the diaphragm. This opens the exhaust port under the outer edge of the diaphragm, and the pressure in the brake chamber is exhausted until a lower balanced pressure is reached. If the air pressure delivered by the brake valve drops to zero, the relay valve releases all pressure from its brake chamber. This releases the brakes and the valve returns to its released position.

A relay emergency valve is used in the air-brake system of trailers. This valve acts as a relay during operation of the brakes. It also automatically applies the trailer brakes when the air lines to the towing vehicle are disconnected or broken. The operation of the relay portion of the valve is much the same as the truck relay valve during normal operation. However, what happens if the air line is disconnected or if the trailer breaks away from the towing vehicle is quite different.

The relay emergency valve is made to go into its emergency position and apply the trailer brakes when there is a quick drop in pressure in the cavity below the emergency diaphragm. For example, if the emergency line is broken, air pressure in the cavity below the emergency diaphragm would flow out of the broken emergency line.

Air pressure above the emergency diaphragm will push the diaphragm down and pull the upper emergency valve down, closing it. Air pressure above the check valve will hold it down and closed.

Air pressure from the trailer reservoir can now flow across the top of the depressed emergency diaphragm into the cavity leading to the brake chambers applying the brakes.

As air pressure escapes from below the emergency diaphragm, pressure above the pressure regulating diaphragm drops instantly. The spring below the pressure regulating diaphragm pushes it up, thus, closing the pressure regulating valve. Air pressure in the trailer reservoir is prevented from escaping through the broken line by the closed upper emergency valve.

To release the trailer brakes, the air reservoir will have to be drained of air or the emergency line reconnected to the towing vehicle.

Lesson 3/Learning Event 2

When the trailer emergency line is connected to the emergency line of the towing vehicle, air flows from the tractor reservoir, through the emergency line, and into the relay emergency valve. This airflow lifts the check valve and flows over the top of the emergency diaphragm into the supply line to charge the trailer reservoir. At the same time, air has also been flowing below the emergency diaphragm and into the cavity above the pressure regulating diaphragm. Air continues to flow in this manner until the air pressure in the cavity above the pressure regulating diaphragm reaches about 70 PSI.

Brake chambers are mounted at each wheel. Their purpose is to convert the energy of compressed air into the mechanical force and motion necessary to operate the brakes. One type of brake chamber consists mainly of a housing, diaphragm and pushrod, and a spring. As compressed air enters the brake chamber behind the diaphragm, the diaphragm forces the adjuster lever which rotates a shaft and cam to apply the brakes. The higher the air pressure admitted to the brake chamber, the greater the force on the pushrod. When the air pressure is released from the brake chamber, the spring returns the pushrod and diaphragm to the released position.

Instead of the brake chamber discussed above, some vehicles use a rotochamber. As air pressure enters the rotochamber behind the diaphragm, it moves the diaphragm forward. The diaphragm moves along the inside wall of the cylinder body with a rolling motion. This motion of the diaphragm forces the pushrod forward. The higher the air pressure admitted to the rotochamber, the greater the force on the pushrod. If all the air pressure is released from the rotochamber, the spring returns the diaphragm and push-rod to the released position.

The air cylinder is another version of a brake chamber. When air enters the compressed air opening and goes behind the piston, the piston will move, driving the pushrod and compressing the piston. When air pressure in back of the piston is released, the piston spring returns the piston and pushrod to the released position.

A slack adjuster is used in air-brake systems to convert back and forth motion to rotary motion and to provide a quick and easy way to adjust the brakes to compensate for brake lining wear. All slack adjusters consist mainly of a worm and gear contained in a body having a lever arm. The gear is splined to fit the brake camshaft. In normal braking, the entire slack adjuster moves as one solid unit. It acts as a simple lever to transmit brake chamber forces to the brake camshaft as the brakes are applied. All adjustments are made by turning the worm shaft. This turns the worm gear and brake camshaft and moves the brake shoes either closer to or farther from the brake drum.

MISCELLANEOUS COMPONENTS

So far, we have only discussed the main components of air-brake systems. Included in the system are smaller items such as check valves, shutoff valves, safety valves, hoses, lines, and fittings. The organizational mechanic will be required to maintain all of these.

Maintenance that will have to be done on these items by the organizational mechanic is much like that on the air-hydraulic system. This maintenance will again be inspecting, testing, adjusting, repairing, and replacing worn or defective parts. Repair will consist mainly of tightening and replacing parts.

Keep in mind that air leaks are your biggest enemy. Be sure to tighten all connections properly so you will not have a loss of air pressure.

Lesson 3/Learning Event 3

Learning Event 3:

DESCRIBE INSPECTION PROCEDURES FOR THE STRAIGHT AIR-BRAKE SYSTEM

INSPECTION AND ROAD TEST

The inspection and road test of wheeled vehicles to determine the condition of the brake system is about the same regardless of whether the brakes are air or air-hydraulic. Therefore, except for a few special air-brake components, the inspection and test is made similar to that for 2 1/2- and 5-ton vehicles.

The inspection consists of checking the air hoses, fittings, chambers, cylinders, and linkage for looseness or damage. Also check for water in the air reservoirs. Then start the engine and observe the air pressure buildup. Check for leaks in the lines, fittings, and components by stopping the engine and seeing if the air pressure gage drops noticeably in a period of one minute. If it does, more testing for leaks is required.

If a visual inspection indicates that the brake system seems to be in good condition, road-test the vehicle to see just how well the brakes operate. During the road test, check for side pull, noise, or clatter. Make several stops to be sure of this check. Immediately after the road test, check the temperature of the brake drums. If they are too hot, the brakes are dragging; if one is too cool, the wheel brake is not operating.

If any deficiencies are noted during the inspection and road test, they must be corrected. We will discuss some of the test and replacement procedures for those air-brake components that are different from the ones on hydraulic or air-hydraulic systems. Table 1 provides a troubleshooting guide for the service brake system.

Table 1. Troubleshooting Service Brakes.

Malfunction	Probable causes	Corrective action
1. Insufficient brakes.	<ul style="list-style-type: none"> a. Brake linings worn. b. Low air pressure (below 80 PSI). c. Defective application valve. 	<ul style="list-style-type: none"> a. Adjust or replace brake shoes. b. Build up air pressure by operating engine at fast-idle speed. c. Test valve; replace if required.
2. Brakes apply too slowly.	<ul style="list-style-type: none"> a. Low air pressure. b. Broken/leaky brake chamber/cylinder. c. Restriction in brake lines or hoses. d. Worn brake shoe linings. e. Application valve defective. f. Quick-release valve inoperative. 	<ul style="list-style-type: none"> a. Build up pressure above 80 PSI by operating engine at fast-idle speed. b. Replace chamber and/or cylinder. c. Test lines/hoses. Replace as necessary. d. Replace brake shoe. e. Test valve; replace if required. f. Test valve; replace if required.

Table 1. Troubleshooting Service Brakes (Continued).

Malfunction	Probable causes	Corrective action
<p>3. Brakes release too slowly or do not release.</p>	<p>a. Restricted air lines.</p> <p>b. Brake actuating cam binding.</p> <p>c. Brake shoe binding on anchor pin.</p> <p>d. Defective application valve.</p> <p>e. Quick-release valve inoperative.</p>	<p>a. Drain air reservoir. Remove and clean brake air lines; replace or repair as necessary.</p> <p>b. Lubricate cam.</p> <p>c. Clean anchor pin and lubricate.</p> <p>d. Test valve for proper operation; replace if required.</p> <p>e. Test valve; replace if required.</p>
<p>4. Brakes do not apply.</p>	<p>a. No air pressure in brake system.</p> <p>b. Restricted or broken tubing or air lines.</p>	<p>a. Build up air pressure above 80 PSI by operating engine at fast idle.</p> <p>b. Inspect air lines; tighten all connections or replace lines as necessary.</p>

Table 1. Troubleshooting Service Brakes (Continued).

Malfunction	Probable causes	Corrective action
5. Brakes grab.	<ul style="list-style-type: none"> a. Grease or grit on brake lining. b. Brake linkage binding. c. Front spring U-bolts loose or broken. d. Loose lining on brake shoe. 	<ul style="list-style-type: none"> a. Replace brake shoe. b. Lubricate anchor pins and actuating cam. c. Tighten or replace U-bolts. d. Replace brake shoe.
6. One brake grabs.	<ul style="list-style-type: none"> a. Improper brake adjustment. b. Weak or broken brake shoe retractor spring. c. Actuating cam binding. d. Brake shoe binding on anchor pin. e. Rear wheel bearings defective or out of adjustment. f. Restricted brake line. 	<ul style="list-style-type: none"> a. Adjust. b. Replace spring. c. Lubricate cam. d. Lubricate anchor pin. e. Inspect bearings; adjust and lubricate or replace if necessary. f. Locate and replace line.

Table 1. Troubleshooting Service Brakes (Continued).

Malfunction	Probable causes	Corrective action
7. Noisy brakes.	<ul style="list-style-type: none"> a. Defective brake shoe assembly. b. Scored or damaged brake drum. c. Bent brake shoes, anchor pins, or actuating cam. 	<ul style="list-style-type: none"> a. Replace brake shoe. b. Replace drum. c. Replace.
8. Uneven brakes.	<ul style="list-style-type: none"> a. Improper brake adjustment. b. Insufficient lubrication. c. Worn brake lining. d. Grease on lining. e. Brake shoe retractor spring weak or broken. f. Air chamber spring broken. g. Chamber diaphragm leaking. h. Brake drum out of round. 	<ul style="list-style-type: none"> a. Adjust brakes. b. Lubricate according to lubrication order. c. Replace brake shoe. d. Replace brake shoe. e. Replace spring. f. Replace chamber. g. Replace chamber. h. Replace drum.

Table 1. Troubleshooting Service Brakes (Continued).

Malfunction	Probable causes	Corrective action
9. Trailer brakes inoperative.	<ul style="list-style-type: none"> a. Hand control valve faulty. b. Hose connections leaking or disconnected. 	<ul style="list-style-type: none"> a. Test valve for proper operation; replace if necessary. b. Check hose connections and proceed as in item 10.
10. Air pressure will not rise to normal or rises slowly.	<ul style="list-style-type: none"> a. Leak in air lines or fittings. b. Clogged compressor discharge line. c. Loose compressor drive belts. d. Defective compressor. e. Defective compressor governor. f. Leak at application valve intake. 	<ul style="list-style-type: none"> a. Locate and tighten all loose fittings or replace lines as necessary. b. Replace line. c. Adjust belts. d. Replace compressor. e. Replace governor. f. Test valve; replace if necessary.

Table 1. Troubleshooting Service Brakes (Continued).

Malfunction	Probable causes	Corrective action
11. Excessive air pressure.	<ul style="list-style-type: none"> a. Air supply valve open. b. Compressor unloading mechanism defective. c. Defective compressor governor. d. Restricted air tube unloading chamber to governor. 	<ul style="list-style-type: none"> a. Close valve. b. Replace compressor. c. Replace compressor governor. d. Replace line.

PRACTICE EXERCISE

1. Which component of a six-wheel truck air-brake system receives air pressure from the brake valve and also from the air reservoir?
 - a. Front brake chamber
 - b. Governor
 - c. Relay valve
2. What is the purpose of the slack adjuster used in air-brake systems?
 - a. Ensure the trailer brakes are applied first
 - b. Compensate for brake lining wear
 - c. Ensure a fast release of the trailer brakes
3. While inspecting a brake system, you find the left front wheel brake is slow to apply. What is probably at fault?
 - a. Quick-release valve
 - b. Application valve
 - c. Brake chamber
4. Most trailer air-brakes are operated through
 - a. two-way valves.
 - b. relay valves.
 - c. emergency relay valves.
5. Which device in an air-brake system is used by the driver to control brake application?
 - a. Relay valve
 - b. Quick-release valve
 - c. Brake valve

Lesson 3

ANSWERS TO PRACTICE EXERCISE

1. c (page 68)

2. b (page 78)

3. c (page 81)

4. a (page 71)

5. c (page 73)

