

TABLE OF CONTENTS

Section	Page
TITLE PAGE.....	i
TABLE OF CONTENTS.....	iii
ADMINISTRATIVE INSTRUCTIONS.....	v
GRADING AND CERTIFICATION INSTRUCTIONS.....	v
INTRODUCTION TO WHEELED VEHICLE CLUTCHES, TRANSMISSIONS, AND TRANSFERS.....	vi
Lesson 1: FUNDAMENTALS OF GEARS	
Learning Event 1: Explain the Principles of Torque.....	1
Learning Event 2: Describe the Purpose, Types, and Operation of Gears and Gear Trains.....	5
Learning Event 3: Explain the Principles of Gear and Torque Ratio.....	13
Learning Event 4: Describe the Construction and Operation of a Planetary Gear Set.....	17
Practice Exercise.....	21
Answers to Practice Exercise.....	22
Lesson 2: FUNDAMENTALS OF CLUTCHES	
Learning Event 1: Describe the Purpose, Construction, and Types of Clutches.....	23
Learning Event 2: Explain the Operation and Maintenance of Clutches.....	28
Practice Exercise.....	31
Answers to Practice Exercise.....	32

Section	Page
Lesson 3: FUNDAMENTALS OF MANUAL TRANSMISSIONS AND POWER TAKE-OFFS	
Learning Event 1: Describe the Types, Construction, and Operation of Manual Transmissions.....	33
Learning Event 2: Describe the Power Flow and Lubrication in Manual Transmissions.....	40
Learning Event 3: Describe the Construction and Operation of Power Take-Offs.....	50
Learning Event 4: Describe the Maintenance of Manual Transmissions and Power Take-Offs.....	54
Practice Exercise.....	61
Answers to Practice Exercise.....	62
Lesson 4: FUNDAMENTALS OF AUTOMATIC TRANSMISSIONS	
Learning Event 1: Describe the Operation and Drive Train Mechanisms of the Automatic Transmission.....	63
Learning Event 2: Describe the Drive Train Arrangements of the Automatic Transmission.....	68
Learning Event 3: Describe the Hydraulic System of the Automatic Transmission.....	79
Practice Exercise.....	93
Answers to Practice Exercise.....	94
Lesson 5: FUNDAMENTALS OF TRANSFER CASES	
Learning Event 1: Describe the Construction and Operation of Transfer Cases.....	95
Learning Event 2: Describe the Construction and Operation of Sprag Units.....	103
Practice Exercise.....	108
Answers to Practice Exercise.....	110
EXAMINATION.....	111

ADMINISTRATIVE INSTRUCTIONS

SUBCOURSE CONTENT

This subcourse contains five lessons, each related to wheeled vehicle clutches, transmissions, and transfers. An introduction presents an overall view of the subject. Each lesson then covers a specific topic pertaining to fundamentals of clutches, transmissions, and transfers. Each lesson is followed by a practice exercise. An examination covering all five lessons is provided at the end of the subcourse.

Supplementary Requirements

Materials Needed. You will need a No 2 pencil and paper to complete this subcourse.

Supervisory Assistance. No supervision is required for completion of this subcourse.

Reference. No supplementary references are needed for this subcourse.

GRADING AND CERTIFICATION INSTRUCTIONS

INSTRUCTIONS TO THE STUDENT

This subcourse has an examination that consists of 30 multiple-choice test items covering five lessons. You must score a minimum of 75 percent on this test to meet the objectives of the subcourse. Answer all questions on the enclosed ACCP examination response sheet. After completing the examination, place the answer sheet in the self-addressed envelope provided and mail it to the Institute for Professional Development (IPD) for scoring. IPD will send you a copy of your score.

Five credit hours will be awarded for successful completion of this subcourse.

INTRODUCTION TO WHEELED VEHICLE CLUTCHES, TRANSMISSIONS, AND TRANSFERS

We know that an internal combustion engine can develop rotary motion power at the flywheel on the back end of the crankshaft. We also know that anytime rotary motion power is available, it can be made to do work.

Let's see how this type of power is applied to various types of machines. If we think about a one-cylinder engine on a lawnmower, the power can be delivered to the mower in one of two ways: by connecting the two units with a belt or by mounting the mower blade directly to the crankshaft of upright engines. Belt-driven mowers contain a device for tightening or loosening the belt so that the mower can be started or stopped while the engine is still running. Some rotary mowers having the upright engine use a mechanical device consisting of disks to connect and disconnect the engine from the cutting blade.

These devices are commonly called clutches. Their purpose is to provide a means of connecting and disconnecting engine power from the machine it is supposed to drive.

The automobile engine must also be disconnected from the vehicle's wheels before the engine can be started. After it is running, the power from the engine must be ready for use as the driver wants it. For instance, the driver must be able to make the vehicle go by engaging the power smoothly and gradually to prevent twisting or breaking vehicle parts and to keep from jerking the people or the load. Some means must also be provided so the engine can make the vehicle go in reverse as well as forward. There must be some way to vary the speed between the engine and the driving wheels so the vehicle will be able to run at high speeds on level roads as well as move heavy loads up steep hills.

Besides furnishing power to make the vehicle move, many engines also have to power such things as winches and hydraulic pumps. Units are provided on vehicles for taking power from the engine and applying it to these devices as it is needed. Most Army trucks can be moved by power to all wheels (front and rear) and this too requires additional units to place the engine power at each of the wheels.

For the most part, the tasks described above are done by units called clutches, transmissions, power take-offs, and transfer cases. It is the job of the mechanic to maintain these units so they will perform their job correctly.

This subcourse is designed to provide you with knowledge of the construction, operation, and maintenance of these units.

**US ARMY LIGHT WHEEL VEHICLE MECHANIC
MOS 63B SKILL LEVEL 3 COURSE**

WHEELED VEHICLE CLUTCHES, TRANSMISSIONS, AND TRANSFERS

SUBCOURSE NO. OD1005

**US Army Ordnance Center and School
Aberdeen Proving Ground, Maryland**

Five Credit Hours

GENERAL

The Wheeled Vehicle Clutches, Transmissions, and Transfers Subcourse, part of the Light Wheel Vehicle Mechanic MOS 63B course, is designed to teach the knowledge necessary to develop the skills for servicing and maintaining clutches, transmissions, and transfers. Information is provided on the construction, use, and types of clutches, manual transmissions, automatic transmissions, and transfers. Information is also provided on gears and gear trains as they apply to transmissions and transfers. The subcourse is presented in five lessons, each lesson corresponding to a terminal objective as indicated below.

Lesson 1: FUNDAMENTALS OF GEARS

TASK: Describe the fundamentals of gears and gear trains.

CONDITIONS: Given information on the construction, use, and types of gears and gear trains and the principles of operation of a simple planetary gear set.

STANDARDS: Answer 70 percent of the multiple-choice items covering fundamentals of gears.

Lesson 2: FUNDAMENTALS OF CLUTCHES

TASK: Describe the fundamentals of friction-type clutches.

CONDITIONS: Given information on the construction and operation of friction-type clutches.

STANDARDS: Answer 70 percent of the multiple-choice items covering fundamentals of clutches.

Lesson 3: FUNDAMENTALS OF MANUAL TRANSMISSIONS AND POWER TAKE-OFFS

TASK: Describe the fundamentals of manual transmissions and power take-offs.

CONDITIONS: Given information on the construction, operation, and lubrication of transmissions and power take-offs.

STANDARDS: Answer 70 percent of the multiple-choice items covering fundamentals of transmissions and power take-offs.

Lesson 4: FUNDAMENTALS OF AUTOMATIC TRANSMISSIONS

TASK: Describe the fundamentals of automatic transmissions.

CONDITIONS: Given information on the operation, drive train, and hydraulic system of the automatic transmission.

STANDARDS: Answer 70 percent of the multiple-choice items covering fundamentals of automatic transmissions.

Lesson 5: FUNDAMENTALS OF TRANSFER CASES

TASK: Describe the fundamentals of transfer cases.

CONDITIONS: Given information on the construction, lubrication, and operation of transfer cases.

STANDARDS: Answer 70 percent of the multiple-choice items covering fundamentals of transfer cases.

***** IMPORTANT NOTICE *****

THE PASSING SCORE FOR ALL ACCP MATERIAL IS NOW 70%.

PLEASE DISREGARD ALL REFERENCES TO THE 75% REQUIREMENT.

LESSON 1 FUNDAMENTALS OF GEARS

TASK

Describe the fundamentals of gears and gear trains.

CONDITIONS

Given information on the construction, use, and types of gears and gear trains and the principles of operation of a simple planetary gear set.

STANDARDS

Answer 70 percent of the multiple-choice items covering fundamentals of gears.

REFERENCES

TM 9-8000

Learning Event 1:

EXPLAIN THE PRINCIPLES OF TORQUE

A task that is familiar to each of us is the process of winding our watch. To do this, we simply grasp the winding knob between our thumb and forefinger and roll the knob. This action causes a shaft to rotate inside of the watch, which, in turn, causes the watch movement spring to wind.

Now, let's think of another form of winding action: that of winding a child's toy. Here again, our intent is to wind a spring so that the energy produced by the spring trying to unwind can make the toy work. The key used to wind toys consists of the shank that fits onto the winding shaft and a fairly long finger grip to turn the key. This device is designed for one purpose: to turn the shaft that will wind the spring. However, the toy spring requires more effort to wind than the watch spring, so the finger grip is larger than the winding knob of the watch.

Lesson 1/Learning Event 1

Suppose we were to try and turn the spring shaft without a key. By gripping it extremely tight we might be able to turn it a little bit, but not enough to wind the spring tight. What is the reason for us not being able to wind it tight?

To begin with, the inner end of the shaft is fastened to one end of a coil spring. The natural shape of the spring forms loose coils. When the spring is wound, the position or shape of the coil is changed as it becomes tighter. However, a large amount of work is needed to wind the coil because the steel spring tries to remain in an unwound condition. The work involved is the twist that is applied to the winding shaft. This twist or rotating effort applied to the shaft is called torque.

Torque is the twisting effort that is applied to make anything rotate. We usually think of it as the work required to rotate a shaft. However, if you were to grasp one end of a barrel, tip it on its edge and roll it, you would be applying torque to the end you grasped.

The effort used to remove the screw cap from a jar is torque.

Another example of torque is the use of a wrench on a bolt, nut, or stud. In this case you use a tool to apply twist. But let's stop and think why. We know that we could not apply enough twist with our fingers to tighten or loosen a bolt and nut, and yet it becomes quite simple when we use a wrench. The reason it becomes simple is because the wrench provides a lever action. We also know that if the wrench handle is long we can turn the nut or bolt much easier than with a short handle.

Now let's think of the bolt or nut as the spring shaft on a watch or toy. With a wrench on the shaft, the spring can be wound quite easily. A person would feel a little foolish winding his watch with a wrench though, so they place a knob on the shaft. The knob is actually a device that is the same as if we had many wrenches sticking out in all directions from the shaft. In other words, the knob being larger than the shaft provides a lever to help overcome the torque required to wind the spring. Keep in mind that torque is twist, and we can increase twisting effort by using a lever.

Now let's discuss how a wheeled vehicle mechanic employs the use of torque.

Let's start at the engine. When a piston is forced down on the combustion stroke, its connecting rod forces the crankshaft throw down. Because the crankshaft itself is kept from moving down by its main bearings, the throw forces the shaft to rotate. However, the shaft is hard to rotate because the flywheel resists moving, and one or more of the other pistons are being forced up on the compression stroke. Therefore, the power stroke of one piston must apply enough twist to the crankshaft to force the others up on compression stroke and still have power left over to do other work. You can see that a great deal of torque is applied to an engine crankshaft.

The purpose of wheeled vehicles is to transport passengers or cargo. The only way this can be done is for the vehicle wheels to move the vehicle in the direction and speed desired by the operator. This means the wheels must be made to rotate. To do this, torque is applied to the shaft that drives the wheels the same as torque is applied to a wrench for tightening a bolt.

The amount of torque or twist that is applied to a shaft or any other given point can be measured. To explain this, let's think about a stud that is being turned into its threads in a piece of metal. For example, we will say that the bolt or stud fits the threads tightly and therefore is quite hard to turn even before it is tightened down.

To explain the measurement of torque, we will use a wrench on the bolt. The wrench handle is 12 inches long and is marked at the 1-, 6-, and 12-inch positions. Further throughout our discussion we will disregard the weight of the wrench.

With the wrench placed on the bolt we want to turn, we now know that some effort will be needed to turn the wrench. We will take a 1-pound weight to apply the effort. If we place the weight on the 1-inch marking, it probably won't be enough to turn the bolt. However, you must agree that there is some twist applied to the bolt. In fact, we know exactly how much torque is being applied against the bolt because we have a 1-pound weight pulling down on the wrench 1 inch from the center of the bolt. The term used to express torque is pound-inch or pound-foot. Sometimes you may see these words reversed. Actually, the reversed words (inch-pounds or foot-pounds) are used to express power or work instead of torque. We will use the terms pound-inches and pound-feet in this lesson. In our experiment, we have placed 1 pound-inch of twist or torque on the bolt.

Lesson 1/Learning Event 1

As the weight is moved out on the wrench handle, the amount of twist being applied to the bolt will increase. Remember the lever action we spoke about. By moving the weight further out on the handle, we are increasing the leverage. If the 1-pound weight is applied at the 6-inch mark, it will be applying 6 pound-inches of torque.

When the weight is placed on the 12-inch mark, it would be applying 12 pound-inches of torque. We can also say that there is 1 pound-foot of torque being applied, because 12 inches is equal to 1 foot. If the wrench was 24 inches long and the weight was placed on the 24-inch mark, we would be applying 24 pound-inches or 2 pound-feet of torque on the bolt.

If we remove the weight and grasp the wrench handle with our hand at the 12-inch mark, we can probably turn the bolt. However, for each pound of pressure we apply with our hand we are applying 1 pound-foot of torque on the bolt, because our hand is 1 foot from the center of the bolt. When we pull the wrench to apply torque on the bolt and only 15 pound-feet of twist is needed to turn the bolt, that is the greatest amount of torque that can be applied with the wrench until the bolt becomes harder to turn.

Now that we understand what effect torque or twist has on a shaft, we will discuss the items used instead of a wrench to turn shafts. These items are called gears

**Learning Event 2:
DESCRIBE THE PURPOSE, TYPES, AND OPERATION OF GEARS AND GEAR
TRAINS**

Automotive vehicles must have many components that can take the power from the engine and deliver it to the wheels of the vehicle. Not only must the power be simply delivered to the wheels, but the components must be arranged to do several things.

Military wheeled vehicles are designed to do the following:

Have great pulling power.

Move at high and low speeds.

Travel in reverse as well as forward.

Operate on rough ground as well as smooth roads.

Deliver power to the front wheels as well as the rear wheels.

A simple shaft, belt, or chain from the engine to the wheels would not allow all of these things to be done. Therefore, components often referred to as gearboxes make up what is referred to as the power train of a vehicle. These units contain various types of gears to do the job.

Gears are made in many shapes and sizes. Their purpose is to transmit power from one shaft to another. The shafts might be parallel to each other or at an angle with each other.

TYPES OF GEARS

You can now see that gears must be shaped for the job they are to do. All gears have certain common features. Usually they are a round wheel with teeth or notches formed some way on the outer edge. They will have a hole in the center so that they can be mounted on a shaft.

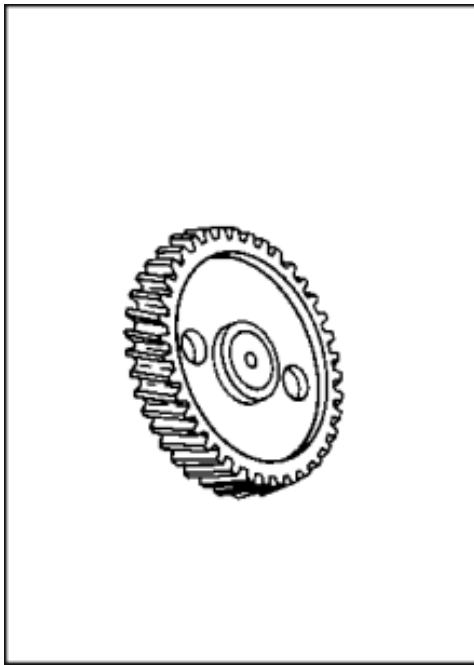

FIGURE 1. EXTERNAL GEAR

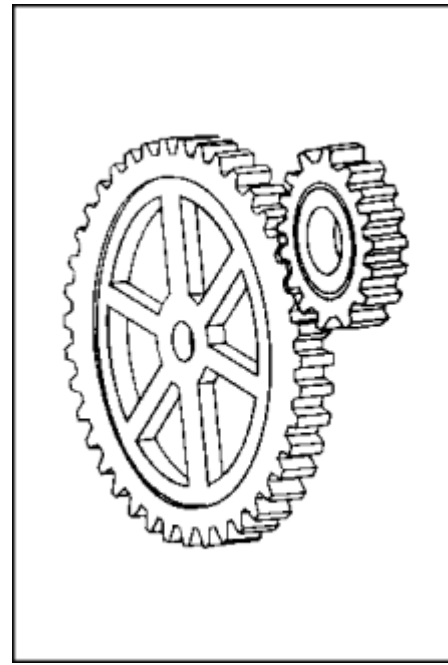

FIGURE 2. SPUR GEAR

The spur gear can be identified by its straight teeth. The teeth are spaced evenly and run straight across the outer face of the gear. This type is called an external tooth gear because the teeth are on the outside. This is the most common type of gear we will see. It can be used to transmit power from one shaft to another as long as the two shafts are parallel.

When two of these gears are in mesh, one can turn the other. The one that is doing the driving is called the pinion or driving gear and the one being turned is called the driven gear.

Notice that when these gears are in mesh, only one tooth of each gear is in contact. This means that the entire load is being driven through one tooth in each gear. As one tooth comes out of mesh, another moves in to take its place. Therefore, there are two things that are problematic about this gear. By having only one tooth engaged at a time, large loads might break off a tooth. Also, the one tooth going into and out of mesh at a time causes these gears to be noisy.

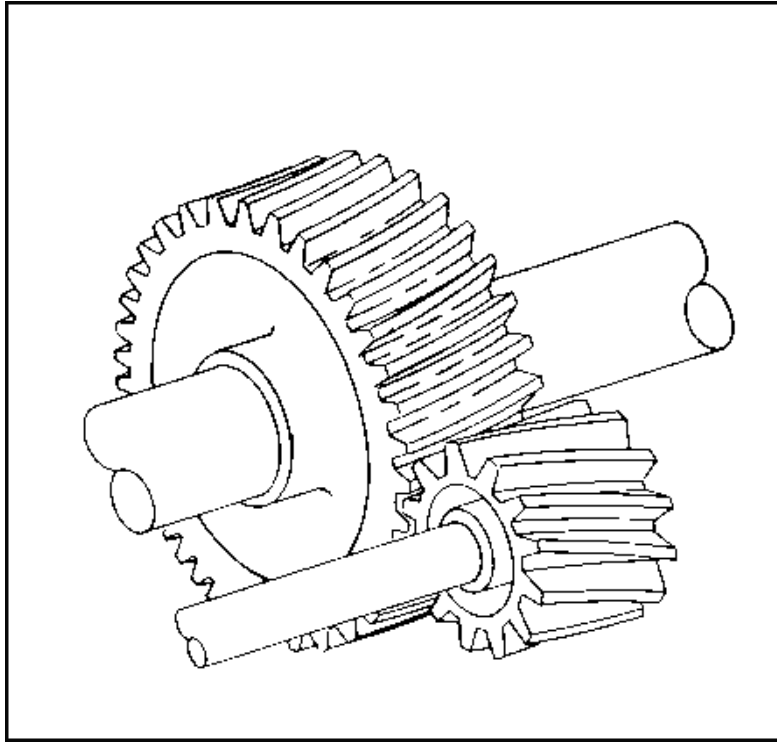

FIGURE 3. HELICAL GEARS.

Another type of gear is the helical tooth gear. The teeth of this gear are cut at an angle. This makes the teeth longer and when two gears are in mesh, portions of two or more teeth are in contact all the time.

Since the force of a load on this type of gear is spread over a larger area, the helical tooth gears can handle larger loads than spur gears can. Also, because of the way the teeth engage and disengage, these gears are fairly quiet.

However, there is a big disadvantage to this type of gear. Whenever a helical gear is driving another gear under load, the gears try to slide sideways on their shafts because of the shape of the teeth. The driving gear will try to slide the other way. This action is called side thrust. When helical gears are used, the shafts must be designed to prevent the gears from moving sideways.

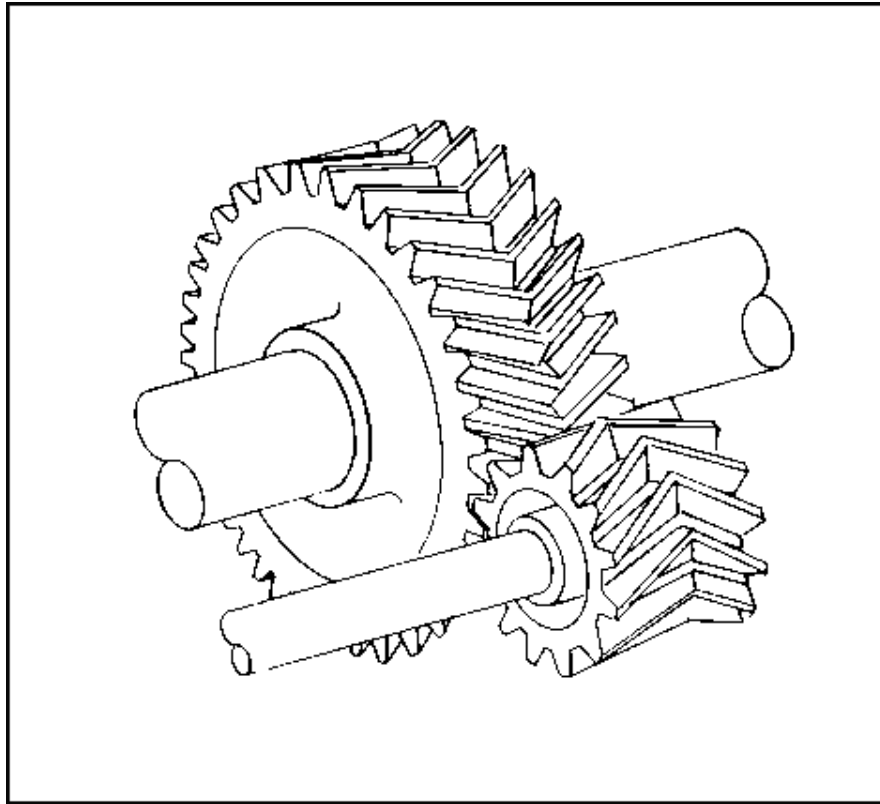

FIGURE 4. HERRINGBONE GEARS.

There are times when gears must be made to handle extremely heavy loads. To use the helical principle where long tooth contact is available, a double helical gear called a herringbone gear was designed. You will notice that there is no side thrust on this type of gear because of its shape. This gear is also fairly quiet.

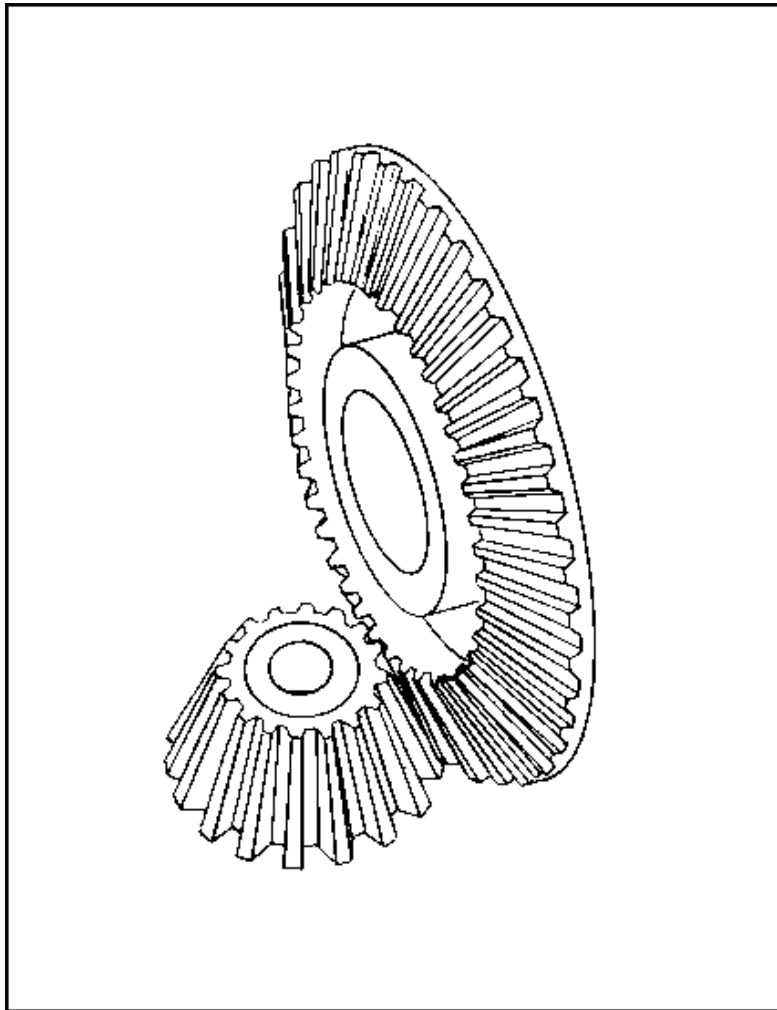

FIGURE 5. BEVEL GEAR.

When power must be delivered at an angle, the teeth of the gears must be cut differently. This type of gear is called a bevel gear. Notice that two of them in mesh will change the direction of power by 90° . These gears are available in several designs.

The spur bevel has straight teeth the same as the regular spur gear, except that the teeth are cut at a 45° angle to the side of the gear.

The skew bevel gear is cut similar to the helical gear, except that the teeth are also cut at a 45° angle to the side of the gear. The advantages of the skew bevel gear over the spur bevel gear are the same as those of the helical gear over the spur gear.

There are other designs of this type of gear such as spiral bevel and hypoid which are used in the rear and front axles of vehicles.

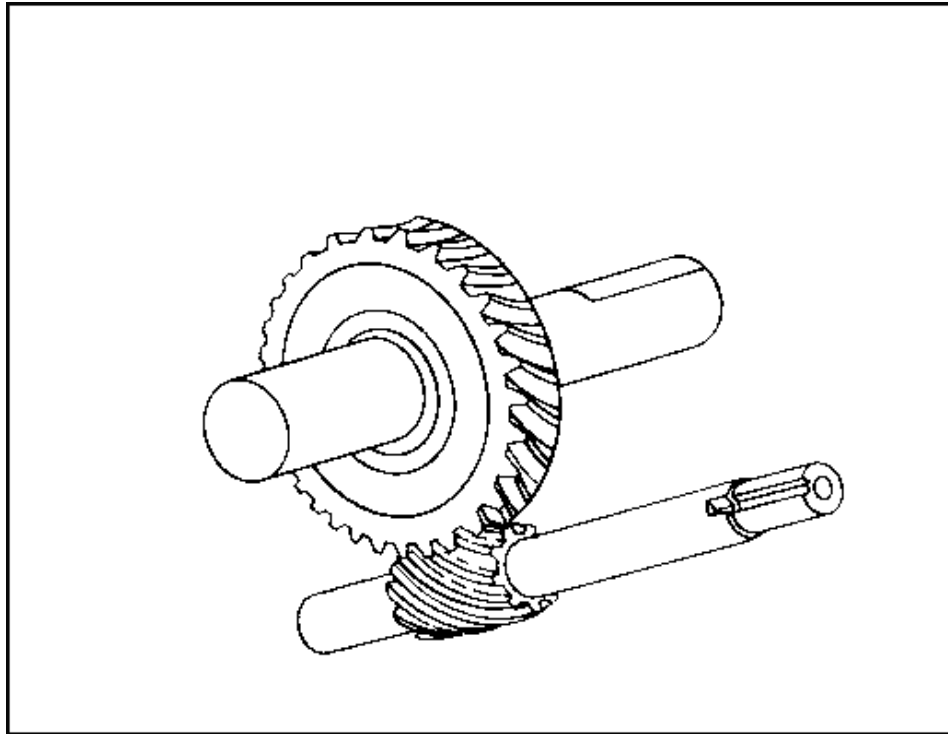

FIGURE 6. WORM GEAR.

The worm gear is another type of gear delivering power at an angle. The principle of this gear arrangement is similar to a bolt and nut. The worm shaft has a coarse thread cut on it. As it rotates, it winds the teeth of the worm gear into it. The worm gear is very compact and quiet and is often used where heavy loads must be transmitted at an angle.

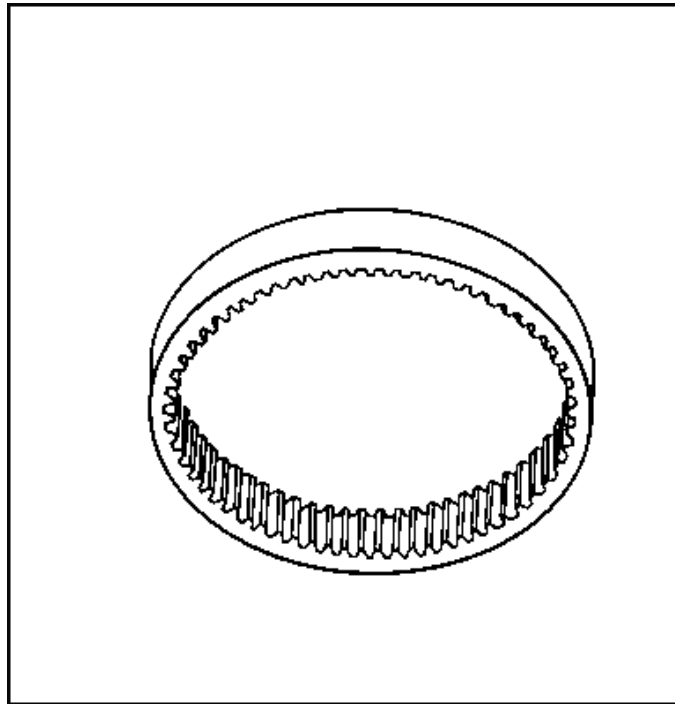

FIGURE 7. INTERNAL GEAR.

Another type of gear is the internal tooth gear. This is a ring with gear teeth cut on the inside. The teeth are usually of the spur type (straight across). This type gear is normally used for special purposes only.

GEAR PRINCIPLES

The speed and direction of rotation of shafts that are gear operated will depend on how the gears are arranged.

When two external tooth gears are in mesh, they will turn in opposite directions. This principle can be used to provide forward and reverse gears on a vehicle.

When a third gear is added to a gear train, it is called an idler gear. The driving and driven gears will turn in the same direction. The idler gear will rotate opposite from the driving and driven gears and will not change the speed or torque of the driven gear.

A large driving gear meshed with a small driven gear will increase speed, reverse direction of rotation, and reduce the amount of torque delivered.

A small driving gear meshed with a large driven gear will decrease speed, change direction of rotation, and increase the amount of torque delivered.

Lesson 1/Learning Event 2

An internal gear meshed with and driving an external gear will increase speed and decrease torque. An external gear meshed with and driving an internal gear will decrease speed and increase torque. Both gears will always turn in the same direction.

A worm shaft driving a worm gear will deliver power at a 90° angle. The worm shaft is always the driving or input member. For each rotation of a single thread worm shaft, the worm gear will rotate the distance of one tooth. Speed and torque ratio of a worm gearset is therefore determined by comparing the number of threads on the worm shaft to the number of teeth on the worm gear. Worm shafts are designed with single or double threads.

**Learning Event 3:
EXPLAIN THE PRINCIPLE OF GEAR AND TORQUE RATIO**

The term gear ratio is used to express the comparison of the speed of rotation between two gears. It is always stated with the first number representing the rotation of the driving gear and the second number representing the driven gear. Also, the first number represents the number of times the driving gear must rotate to make the driven gear rotate one turn.

Some examples of how gear ratio is stated are:

A 1:1 ratio indicates both gears are rotating at the same speed.

A 2:1 ratio indicates that a small driving gear is in mesh with a driven gear twice as big. The driving gear must turn twice to turn the driven gear once.

A 0.6:1 ratio indicates the driving gear is biggest. For every three turns it makes, the driven gear will rotate five times. Therefore, the driving gear only has to make six-tenths of a revolution to rotate the driven gear once.

Gear ratio between gears can be determined by counting the teeth of the driving and driven gear. You must remember that when two gears are in mesh, as the driving gear rotates the distance of one tooth, the driven gear will rotate the same amount.

TORQUE RATIO

To understand the torque ratio of gears, it is necessary to understand the principle of leverage as it applies to gears. If you recall, we discussed applying torque to a bolt earlier in the lesson. To discuss torque ratio between gears, we must think of the force from a shaft to a gear, from that gear to another gear, and from the second gear to the shaft it is mounted on. To do this, we will refer to the items as an input shaft and gear and an output gear and shaft. The input is the driving member, and the output is the driven member.

Let's first look at the input member. The shaft and gear are bringing the turning force into the gear train. For our purpose, we will say that an engine or motor is driving the input shaft and is applying 25 pound-feet of torque on the shaft.

Lesson 1/Learning Event 3

To begin with, we can think of each tooth on a gear as being the same as the lever or wrench we discussed earlier. Remember, when two gears are in mesh, only one or parts of two teeth are touching each other at any one time. Therefore, we must remember that the entire load between two gears is on these teeth.

For our discussion here, we will think of the driving gear as having just the one tooth that is going to do the work. Further, to help understand it a little better, we will say that the gear is 2 feet in diameter so the one tooth will be exactly 12 inches long.

We said that there was a torque of 25 pound-feet applied to the shaft. This means that if the torque was in the direction of rotation, it could lift 25 pounds out on the 12-inch mark or at the end of the tooth. This is just the reverse of what we explained with the wrench. Here, the shaft is turning the gear; with the wrench, we wanted to turn the shaft, except we used a bolt instead for our example.

By remembering the laws of leverage, we know that a smaller gear will deliver more torque than a larger gear. At the 6-inch mark (the size of a 12-inch gear instead of a 24-inch gear), the tooth could lift 50 pounds because of a greater leverage. You can prove this yourself by holding a stick straight out at arm's length. Have someone hang a small weight on the very end of the stick. You will notice how hard it is to hold the weight. Now have the person take the weight off the end of the stick and hang twice as much weight on the center. You will see that it requires the same effort to hold twice the weight in the center as it does to hold the single weight on the end.

From this, we can see that a small driving gear in comparison to the driven gear can deliver more torque (drive a heavier load) than a big gear. After you have gained experience, you will notice that the driving gear in almost all gear trains is smaller than the driven gear. An exception to this is if you want increased speed instead of torque, then the input or driving gear would be bigger than the driven gear.

Now we will mesh this one tooth of the driving gear with one tooth of a driven gear. Both gears are the same size.

When thinking of the driven member of a gear train, we think of it exactly the same as a bolt with a wrench on it. The longer the wrench is, the easier it is to turn the bolt.

We said that the input gear could apply a force of 25 pounds on the end. This, then, is the amount of force it will apply to the tooth of the driven gear. Because the tooth of the gear is 1 foot long, a torque of 25 pound-feet will be applied against the shaft on which the driven gear is mounted.

Again, remembering our discussion of the wrench, we know that more effort is required to turn the bolt with a short wrench than with a long wrench. Therefore, if we applied the input force of 25 pounds against an output tooth 24 inches long, we would get twice as much torque on the shaft as on a tooth 12 inches long.

Here again, we can compare the output gear to the knob you use to wind your watch. As the knob is made bigger, it is easier to wind the watch. The same principle applies with the driven gear in a gear train. When the driven gear is bigger than the driving gear, you can increase torque.

How does all of this apply to you as a wheeled vehicle mechanic? Well, let's look at a few things about a wheeled vehicle that depend on gears.

To begin with, the vehicle engine can only produce so much power. When it is running fast, it produces more power than when it is idling. The power developed by the engine is sent to the vehicle in the form of twisting motion or torque at the flywheel at the end of the crankshaft.

When the vehicle is started from a standstill, a great deal of torque is required to get it in motion. In addition, the engine is not running at high speed at this time. Therefore, torque from the engine is applied to a small driving gear which, in turn, drives a large driven gear. This increases torque and helps the engine get the vehicle started.

After a vehicle is in motion, less torque is required to keep it in motion. When this occurs, the driving gear and driven gear can be nearer to the same size. In other words, we want the gear train to develop speed more than torque.

When the vehicle comes to a hill, the ratio will have to be changed again. Now the driving gear will have to be smaller than the driven gear to increase the torque. In doing so, we are giving up speed to increase torque.

Lesson 1/Learning Event 3

To sum up torque ratio, we can compare it with gear ratio.

If the driving gear has 12 teeth and is driving a large driven gear with 24 teeth, we have a gear ratio of 2:1. In other words, the driving gear has to rotate two times to make the driven gear rotate once. In this gear train, we double the torque and cut the speed in half.

If the driving gear is the same size as the driven gear, the gear ratio is 1:1. The input and output torque and speed are the same.

If the input gear has 24 teeth and the output gear has 12 teeth, the gear ratio is 0.5:1. In this gear train, we are reducing torque and increasing speed.

OPERATION OF A GEAR TRAIN

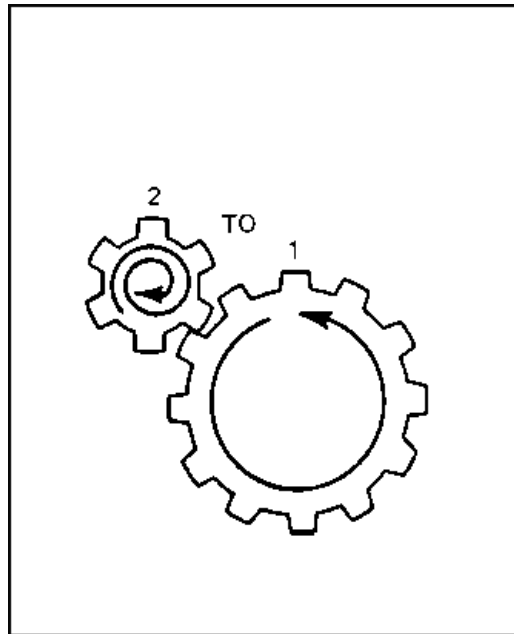

FIGURE 8.

Let's imagine that a crank is attached to gear 1 in the illustration above. When the crank is turned, the shaft will cause gear 1 to turn in the same direction as the crank. The amount of torque applied on the shaft will depend on how hard you crank and the resistance of the paint in the bucket.

Gears 1 and 2 are external gears in mesh and will therefore rotate in opposite directions. Because gear 1 is larger than gear 2, gear 2 will be turning faster than gear 1. This will result in a loss of torque. Remember, in a gear train, we must decrease torque to increase speed.

**Learning Event 4:
DESCRIBE THE CONSTRUCTION AND OPERATION OF A PLANETARY GEARSET**

It is often necessary to design gear trains that will provide many gear ratios. Of necessity, these trains must not be too large and bulky. The answer to this requirement is planetary gearing.

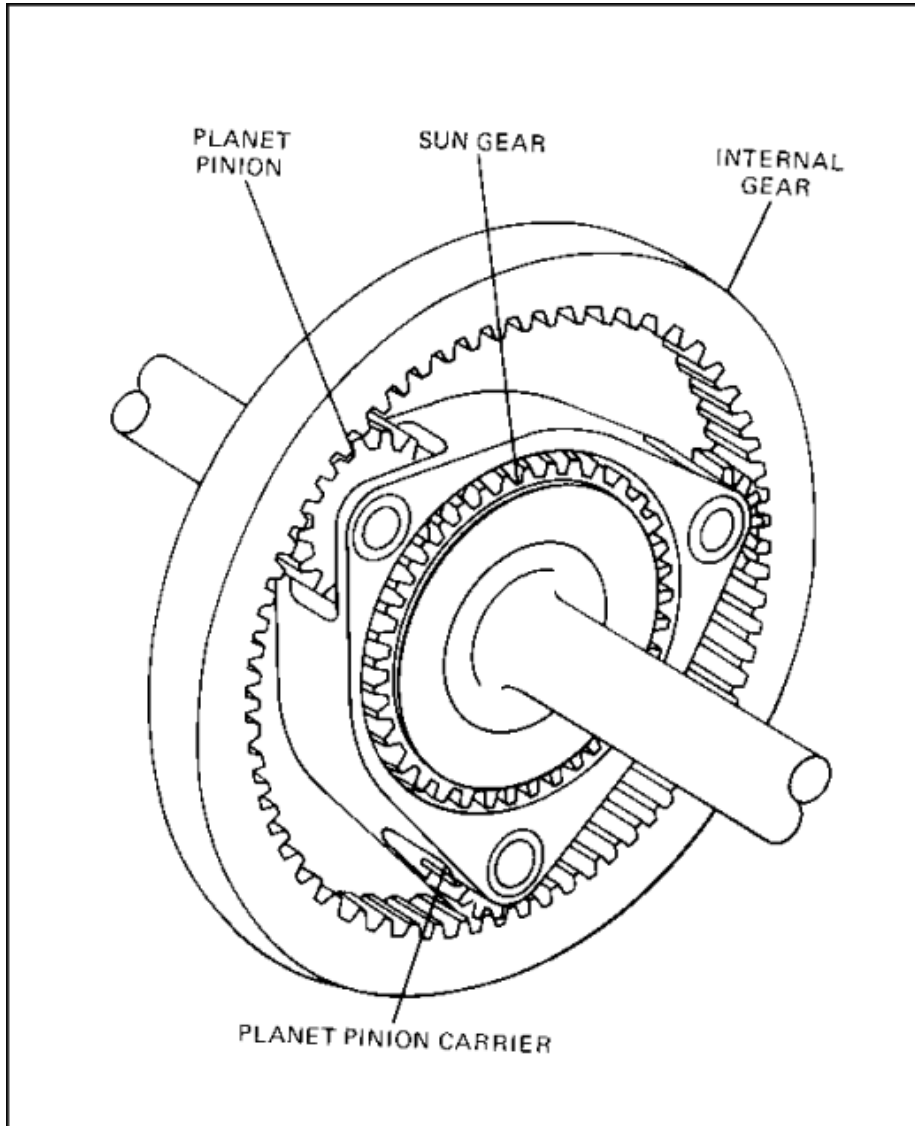

FIGURE 9. PLANETARY GEAR SYSTEM.

Notice the arrangement of the components in the set. Because of the resemblance of the planetary pinions to the planets of the universe circling around the sun, the set was given the name planetary gearset.

Lesson 1/Learning Event 4

The center or sun gear can be either a spur gear or helical gear. It will contain a through shaft so that it can act as either an input or output member.

Normally, three planetary pinions are in mesh with the sun gear at all times. Some sets will have two and others four. They are mounted on and are free to rotate on individual shafts on the planet carrier, which is a framework designed to hold the pinions in their respective positions. The planet carrier can be rotated so that the pinions walk around the sun gear. The carrier also contains a shaft so that it may act as an input or output member.

The outer internal gear is in constant mesh with the planet pinions and is called the ring gear. It can also be an input or output member.

The principle on which the planetary gearset operates is based on driving one unit, holding one unit, and taking the output from the free unit.

If we place a brake band around the ring gear, we can prevent it from turning. If the sun gear is driven under this condition, it will cause the planet pinions to rotate. With the ring gear held from turning, the planet pinions will have to walk around on the inside of the ring gear and the outside of the sun gear. In doing so, the planet pinions will carry the planet carrier around with them.

If the planet carrier is held so that it cannot rotate and the sun gear is driven, the planet pinions will force the ring gear to turn.

If the planet carrier is held and the ring gear is driven, the planet pinions will force the sun gear to turn. If the sun gear is held and the planet carrier is driven, the planet pinions will be forced to rotate and they will drive the ring gear.

Actual use of planetary gears in such things as automatic transmissions, disk clutches, and brake bands control the holding and driving members. Usually, the bands and clutches are controlled automatically.

OPERATING PRINCIPLES

To fully understand the movement of each member of a planetary system, let's consider a few basic operating principles of a planetary gearset.

If the planetary carrier and the sun gear are held together, the pinions cannot turn because they are locked by the sun gear. This will cause the unit to turn as one unit. None of its parts will turn by themselves. This will give us direct drive just as if we had a one-piece shaft.

If the sun gear is held and the planetary carrier is turned, then the ring gear will turn. The pinions will "walk" around the sun gear because the sun gear will not move. The pinions turn as they walk around the sun gear and are in mesh with the ring gear; therefore, the ring gear is pushed by the turning pinion. The ring gear will turn in the same direction as the carrier.

If the ring gear is held and the sun gear is turned, then the carrier will turn. The pinions are in mesh with the sun gear, and, when the sun gear is turned, the pinions will turn. The pinions are also in mesh with the ring gear. With the ring gear held, the pinions therefore walk around the ring gear. This causes the carrier to turn with the pinions.

If the carrier is held and the sun gear is turned, then the ring gear turns in reverse. Because the pinions are in mesh with the sun gear, when the sun gear is turned, the pinions also turn. However, the pinions turn in the opposite direction of the sun gear. The pinions are also in mesh with the ring gear and drive the ring gear because the carrier is held so that it cannot turn. When an external gear is driving an internal gear, the direction of turning is the same. Therefore, the planet pinions turning opposite from the input rotate the ring gear in reverse.

There are five basic rules of planetary gear operation:

- If the planet carrier is used as the output, the set operates in reduction (slower speed, more torque).
- If the planet carrier is the input, the set operates in overdrive (more speed, less torque).
- If the planet carrier is held, the set operates in reverse.

Lesson 1/Learning Event 4

- If any two parts are locked together, the set operates in direct drive.
- If no parts are locked together and if none are held, the set operates in neutral.

Here are a few more things you should also remember.

- An input member receives power from a source such as an engine.
- An output member transmits power to the driving wheels of a vehicle.
- A stationary member is one that is held by a band or clutch so that it cannot turn.
- Locked members are held together.

SPEED RANGES OF A PLANETARY SET

Using the first three of the above rules, we can get six speed ranges. Remember, when we reduce speed, we increase torque, and when we increase speed, we reduce torque.

If the sun gear is held and the planet carrier is turned, the ring gear will turn faster than the carrier (overdrive).

If the sun gear is held and the ring gear is turned, the planet carrier will turn slower than the ring gear (reduction).

If the ring gear is held and the sun gear is turned, the planet carrier turns slower than the sun gear (reduction).

If the planet carrier is held and the ring gear is turned, the sun gear turns in reverse faster than the ring gear (overdrive and reverse).

If the ring gear is held and the planet carrier is turned, the sun gear turns faster than the carrier (overdrive).

If the planet carrier is held and the sun gear is turned, the ring gear turns in reverse slower than the sun gear (reduction and reverse).

PRACTICE EXERCISE

1. What gear, when meshed with a similar gear, will transmit power at a 90° angle?
 - a. Spur
 - b. Helical tooth
 - c. Bevel

2. Which pressure will apply the most torque to a bolt?
 - a. 100 pounds on a wrench 1 foot long
 - b. 60 pounds on a wrench 2 feet long
 - c. 30 pounds on a wrench 3 feet long

3. The effort applied to a shaft to make it turn is called
 - a. torque.
 - b. power.
 - c. energy.

4. What is the result when one external tooth gear drives another?
 - a. Reduction in speed
 - b. Reversal in direction of rotation
 - c. Reduction in torque

5. What is the result when an internal tooth gear drives an external tooth gear?
 - a. Direction of rotation is kept the same
 - b. Speed is decreased
 - c. Torque is increased

ANSWERS TO PRACTICE EXERCISE

1. c (page 9)
2. b (page 4)
3. a (page 2)
4. b (page 11)
5. a (page 12)

**LESSON 2
FUNDAMENTALS OF CLUTCHES**

TASK

Describe the fundamentals of friction-type clutches.

CONDITIONS

Given information on the construction and operation of friction-type clutches.

STANDARDS

Answer 70 percent of the multiple-choice items covering fundamentals of clutches.

REFERENCES

TM 9-8000

Learning Event 1:

DESCRIBE THE PURPOSE, CONSTRUCTION, AND TYPES OF CLUTCHES

The job of the clutch in a wheeled vehicle is to connect and disconnect the engine power to or from the gears and shafts that drive the wheels. Since the internal combustion engine does not develop too much torque when it is first started, it must be disconnected from the drive mechanism until it has had time to develop enough speed and torque to start moving the vehicle. The engine power can then be gradually applied to provide smooth engagement. This will lessen the shock on the driving parts. After the clutch is fully engaged, it must transmit all the engine power to the transmission without slipping. The engine power must also be disconnected from the drive system when the gears in the transmission are being shifted from one gear ratio to another.

CONSTRUCTION

The main parts of the clutch are the driving members, the driven members, and the operating members.

The driving members are attached to the engine crankshaft and turn with it. They usually consist of two cast-iron plates or flat surfaces machined and ground to a smooth finish. Cast iron is used because it contains enough graphite to provide some lubrication when the driving member is slipping during clutch engagement. One of these surfaces is usually the rear face of the engine flywheel. The other is a heavy, flat ring, one side of which has a machined surface. This part is known as the pressure plate, which is fitted into a steel cover and contains some of the operating members. It is bolted to the flywheel. We will discuss the operating members contained in this assembly later in the lesson.

The driven member is attached to and turns with the transmission input or clutch shaft, also called the main drive pinion. It is a disk with a splined hub and is free to slide on the splines of the shaft, but it drives the shaft through these same splines. The driven member may be called a clutch plate or a clutch disk. We will call it a clutch disk to keep from confusing it with the pressure plate.

The clutch disk is usually made of spring steel in the shape of a single flat disk or a number of flat segments. Facings are attached to each side of the disk by means of copper rivets. These facings must be able to withstand the heat produced by friction when the clutch is slipping. The most commonly used facings are made of cotton and asbestos fibers woven or molded together and impregnated with a binding agent. Very often, copper wires are woven or pressed into the material to give it more strength.

To make clutch engagement as smooth as possible and eliminate chatter, several methods have been used to give a little flexibility to the driven disk. One type of disk is "dished" so that the inner and outer edges of the facing make contact with the driving members first, and the rest of the facing makes contact gradually as the pressure on the disk increases and the disk flattens out. In another type, the steel segments attached to the splined hub are slightly twisted, which also causes the facings to make gradual contact as the disk flattens out.

The driven member of the clutch usually has a flexible center to absorb the vibrations caused by the crankshaft, which would be sent through the drive assembly unless they were eliminated. The flexible center is usually made up of steel springs placed between the hub and the steel disk. The springs permit the disk to momentarily turn faster or slower than its hub. At times, the springs may be fully compressed; the disk then returns to its original position when the spring decompresses. This slight backward and forward movement, permitted by the spring, allows the clutch shaft to turn at a more steady rate than the crankshaft. This reduces some of the vibration and results in a smoother power flow.

The operating members consist of the components required to apply and release the pressure which holds the driving and driven members in contact with each other; they include such things as springs, linkage, levers, bearings, and so forth, depending on the type of clutch.

TYPES OF CLUTCHES

There have been several kinds of clutches used on automotive vehicles. They are made to be used on vehicles ranging from small passenger cars to large tractors and tracked vehicles.

One way clutches are classified is by the type of spring used to hold the driving and driven members together. A few of these are single, diaphragm, and helical spring clutches.

In clutches where the diaphragm is used instead of coil springs, the diaphragm is a cone shaped of spring steel. The diaphragm is mounted between the cover and the pressure plate so that the diaphragm is nearly flat when the clutch is in the engaged position. The action of this type of spring is similar to that of the bottom of an ordinary oil can. The outer rim of the diaphragm is secured to the pressure plate and is pivoted on rings so that pressure applied at the inner section will cause the outer rim to move away from the flywheel. This draws the pressure plate away from the clutch disk, releasing or disengaging the clutch. When the pressure is released from the inner section, the oil can action of the diaphragm causes the inner section to move out and the movement of the outer rim forces the pressure plate against the clutch disk, engaging the clutch.

In single spring clutches, the pressure plate applies pressure to the clutch disk through an adjusting plate sleeve and a series of toggle levers. When the clutch release bearing moves forward it applies pressure to the lower portion of the toggle lever through the adjusting plate sleeve. This moves the toggle levers away from the pressure plate. The pressure plate is then pulled away from the clutch disk by springs. In this single spring, the pressure may be exerted by a single, large coil spring.

In helical spring clutches, a system of levers pivoted on the cover forces the pressure plate away from the driven disk and against the pressure springs when the clutch release bearing moves forward against the inner ends of the levers.

Automotive clutches are also classified by the number of plates or disks used in their construction.

The single plate clutch has one driven disk between the flywheel and the pressure plate. The flywheel is not considered to be a plate even though it acts as one of the driving surfaces.

A double plate clutch is different only in that another disk and plate have been added.

MULTIPLE-DISK CLUTCH

Driving disks have lugs similar to gear teeth around their outside edges. These mesh with internal splines in the clutch case, which is bolted to and rotates with the flywheel. The driven disks are carried on parallel pins, which are solidly set in the clutch spider. This construction permits movement of all the disks and the pressure plate to provide clearance between them. When the clutch is engaged, the spring moves the pressure plate forward, holding all the disks together firmly. This causes the clutch spider to revolve and turn the clutch shaft to which it is keyed. In multiple-disk clutches, the facings usually are attached to the driving disks. This reduces the weight of the driven disks and, consequently, their tendency to continue spinning after the clutch is released. Because of the considerable number of disks involved, the pressure plate has to move farther to separate the disks completely than it does in clutches having fewer driving and driven members. There is, therefore, less mechanical advantage on the clutch pedal, and a greater foot pressure is required to depress it.

In a wet-type clutch, the disks and the entire internal assembly run in an oil bath. The operation of this type of clutch is similar to that of the dry type, except that the friction surfaces are made of different materials, and the gradual engagement between the driving and driven members is caused by pressing the oil from between the disks. As the oil is eliminated, the friction increases.

Helical spring (semicentrifugal). Many passenger car clutches are of the semicentrifugal type, in which the pressure between the plates is increased as the speed of the clutch increases. This is accomplished by means of centrifugal weights built into the outer ends of the release levers so that the outward pull of centrifugal force is transformed into pressure on the plate. This construction permits the use of relatively light clutch springs, thus facilitating the depression of the clutch pedal for gear shifting.

Learning Event 2:

EXPLAIN THE OPERATION AND MAINTENANCE OF CLUTCHES

The transmission of power through the clutch is accomplished by bringing one or more rotating drive members secured to the crankshaft into gradual contact with one or more driven members secured to the unit being driven. These members are either stationary or rotating at different speeds. Contact is established and maintained by strong spring pressure controlled by the driver through the clutch pedal and suitable linkage. As spring pressure increases, the friction increases; therefore, when the pressure is light, the comparatively small amount of friction between the members permits a great deal of slippage. As the spring pressure increases, less slippage occurs until, when the full spring pressure is applied, the speed of the driving and driven members is the same. All slipping has stopped and there is, in effect, a direct connection between the driving and driven parts.

Most of the clutches you will be working with will probably be plate-type clutches, so let's see just what takes place in the operation of a single-plate clutch.

When the clutch is fully engaged, the driven disk is clamped between the pressure plate and the engine flywheel by the springs.

When the clutch pedal is pushed down, linkage from the pedal moves the release yoke or fork on its pivot or hinge. This puts pressure on the release bearing sleeve or collar containing the release bearing. The race of the release bearing pushes against the clutch release levers and moves them on their pivot pins. The outer ends of the release levers move the pressure plate to the rear, compressing the clutch pressure plate spring. This allows the driving members to turn free of the driven members. When the clutch is disengaged, the release bearing turns with the flywheel; the driven disk and the clutch shaft or transmission drive pinion stop turning.

When the clutch pedal is allowed to return to the engaged position, all clutch parts, except the release bearing and collar or sleeve, turn with the flywheel.

INTRODUCTION TO CLUTCH MAINTENANCE

Maintenance of clutches by the unit mechanic includes inspecting, adjusting, testing, and repairing. The only repair by the unit mechanic will normally be replacing worn or damaged linkage. Inspecting and adjusting are probably the most important.

When inspecting the clutch, the mechanic should examine the clutch linkage for worn, bent, broken, or damaged parts. The mechanic should next check the clutch pedal free travel. What is free travel? Well let's see just what is meant by this term.

Have you ever driven a vehicle that has a clutch pedal? Remember how the pedal is easy to push down a little way, then gets hard to push? The distance that the clutch pedal is easy to push down is called clutch pedal free travel. In other words, free travel is the distance the clutch pedal must be pushed down before the clutch starts to disengage.

Clutch pedal free travel is caused by slack in the linkage; also, the amount of movement needed before the release bearing starts pushing on the release levers. Clutch pedal free travel should be checked often, as free travel gets less as the clutch wears. Insufficient free travel can keep the clutch from fully engaging. If it is not fully engaged, it may slip and wear out quickly.

Too much free travel will cause the clutch not to completely release. This causes the gears to clash and makes it hard to shift gears.

Clutch pedal free travel can be measured by first measuring the distance from the clutch pedal to the floor of the cab.

Next push the pedal down until it gets hard to move; again measure the distance from the clutch pedal to the floor. The difference between the two measurements is the clutch pedal free travel.

OPERATIONAL CHECK

After the clutch pedal free travel has been checked and adjusted if required, the vehicle should be road tested to see if the clutch is operating properly. During the road test, perform the following:

Lesson 2/Learning Event 2

Check the clutch for slippage. This can be done by setting the parking brake, placing the vehicle in high gear, and trying to move the vehicle by slowly engaging the clutch. The engine should stall. The cause of a clutch slipping could be not enough pedal free travel, worn driven disk facings, or a defective pressure plate assembly.

Check for clutch chatter. This could be caused by oil or grease on the clutch disk facings or by improper connections. To determine if connections are improper, inspect the transmission mountings, propeller shafts, universal joints, and engine mountings. Tighten as required. If there is oil or grease on the disk facings, the clutch disk will have to be replaced.

Check for noise. A squealing noise when the clutch is released but goes away when the clutch is engaged is likely caused by a defective release bearing.

PRACTICE EXERCISE

1. Which of the following are driving members of a clutch?
 - a. Pressure plate and disk
 - b. Pressure plate and flywheel
 - c. Flywheel and release bearing

2. What moves the clutch release levers when the clutch is being disengaged?
 - a. Pilot bearing
 - b. Clutch plate
 - c. Release bearing

3. Why are springs used in the clutch disk?
 - a. To reduce clutch slippage
 - b. To strengthen the disk
 - c. To smooth out the power flow

4. What is one thing the unit repairer should always check for when inspecting the clutch?
 - a. Worn linkage
 - b. Warped disk
 - c. Loose disk facings

5. Clutch pedal free travel is the amount of pedal movement.
 - a. before the clutch starts to engage.
 - b. before the clutch starts to disengage.
 - c. after the clutch has disengaged.

ANSWERS TO PRACTICE EXERCISE

1. b (page 24)
2. c (page 28)
3. c (page 21)
4. a (page 29)
5. b (page 29)

**LESSON 3
FUNDAMENTALS OF MANUAL TRANSMISSIONS AND POWER TAKE-OFFS**

TASK

Describe the fundamentals of manual transmissions and power take-offs.

CONDITIONS

Given information on the construction, operation, and lubrication of transmissions and power take-offs.

STANDARDS

Answer 70 percent of the multiple-choice items covering fundamentals of transmissions and power take-offs.

REFERENCES

TM 9-8000

Learning Event 1:

DESCRIBE THE TYPES, CONSTRUCTION, AND OPERATION OF MANUAL TRANSMISSIONS

When a vehicle is standing still, a large amount of power is required to start it moving. If the vehicle is in motion, a large amount of effort is not needed to keep it in motion. This is because a vehicle that is moving will tend to stay in motion, and a vehicle that is standing still tends to remain still. The vehicle engine has enough power or turning force to keep the vehicle moving on a good road, but to move from a standing position, more power is needed. More power is also needed when operating the vehicle off the road on rough ground and when climbing steep hills.

To obtain the power needed so the driver can keep the vehicle operating properly under all conditions, a transmission is installed in the vehicle. Some military wheeled vehicles use a manual transmission. This transmission provides the operator with a group of gear ratios that will increase the engine turning power to meet all road conditions.

Since the engine does not deliver enough power at low speeds, the operator must place the gears of the transmission in a gear ratio that will keep the vehicle moving with the engine speed in the medium ranges. Forcing the vehicle to pull a load at a low engine speed is called "lugging the engine," which results in engine wear and possible damage.

A means must also be provided to permit the operator to move the vehicle in reverse. You cannot make the engine run backward, so the transmission must provide a means of reversing the engine power output with gears.

The transmission receives the twisting effort or torque of the engine and either increases it with gears or passes it through directly. Each shift position, except direct drive or overdrive, will provide an increase in the torque delivered by the engine. The shift positions are called transmission speeds or ratios. The number of speeds and size of a transmission will depend upon the size and type of vehicle. For example, the transmission of the M151-series, 1/4-ton truck has four forward speeds and a single reverse. A commercial sedan, which is a small vehicle with a powerful engine, may have a transmission that has only three forward speeds and a single reverse. Large truck-tractor type vehicles sometimes have transmissions that provide fifteen forward speeds and three reverse speeds.

It is possible to mount the transmission in several different locations, but on most wheeled vehicles it is bolted to the rear of the engine. This construction makes a single solid unit of the engine, clutch, and transmission. The transmission on some vehicles is supported entirely by the flywheel housing of the engine. Another means of supporting the transmission is to provide mounts on the transmission housing assembly. This supports the transmission and also acts as a rear engine support. Rubber pads on the mounting surfaces aid in preventing engine and transmission vibration and noise from being sent to the vehicle body.

TYPES OF TRANSMISSIONS

There are two types of manual, selective-speed transmissions that are used in wheeled vehicles. These are the sliding-gear and the constant-mesh types.

The sliding gear was the first type used. Transmission speeds were obtained by sliding gears that were mounted on a splined main shaft forward or rearward to mesh with other gears. The splined shaft contained grooves running lengthwise that allowed the gears to slide back and forth freely. When the gear turned, the shaft was forced to turn at the same speed. These early sliding-gear transmissions used straight spur-tooth gears that made shifting between speeds very hard. Also, the straight spur-tooth gears were noisy when in operation.

The constant-mesh transmission is better than the sliding-gear transmission because the major working gears are always in mesh and the shifting is done with gear clutches. A gear clutch consists of an external gear with the teeth on the outside that mesh with a matching internal gear that has teeth on the inside. The gear clutch shifts into mesh much easier than two external tooth gears. Shifting into various ratios was made much better by adding a synchronizer assembly to the constant-mesh transmission. The synchronizer adds a small friction clutch to the sliding-gear clutch of the constant-mesh transmission. This clutch forces the two gears to rotate at the same speed before the teeth mesh so that the shift is made without gear noise. Presently, manual transmissions in military vehicles use some of the features of each of the two types.

CONSTRUCTION OF TRANSMISSIONS

In this lesson, we cannot possibly discuss each type of transmission used in military vehicles. Therefore, the construction and operation presented here are based upon a simple three-speed-forward and one-speed-reverse transmission that is used in smaller wheeled vehicles. It should be kept in mind that all manual transmissions are similar in construction, but as the vehicle becomes larger, more speed ratios and heavier parts are needed.

The manual transmission uses gears to increase engine torque for delivery to the wheels. These gears must be made to very exact measurements and operate quietly under hard use. Mounting of the gears must be correct to within a few thousandths of an inch.

The transmission case provides a firm base in which the required shafts and gears are mounted. Most transmission cases are made of cast iron, but a few models have been made of an aluminum alloy to reduce weight. Cast iron provides a strong, long-lasting case that is low in cost. Some drawbacks of cast iron are that it breaks easily, is heavy, and is not easily repaired.

In addition to mounting all of the inner components, the case also acts as a reservoir or storage point for the gearbox lubricating oil. Plugs in the bottom and side of the case provide a means of checking oil level or draining the lubricant. These plugs can be identified by their square-type head.

The front of the case is machined to a smooth surface to match the mounting surface at the rear of the engine flywheel housing. On some models, the front of the transmission contains a bell-shaped housing that becomes the rear of the flywheel housing. On most military transmissions, openings and mounting surfaces are made on the right and left sides of the case to allow for attaching additional gearboxes called power take-offs. When not used, metal plates are bolted over the openings to seal the transmission case. Openings in the front and rear of the case are machined to a smooth finish to provide an accurate mounting for shaft bearings. The top of the case is open with smooth machined edges and threaded mounting holes for the cover assembly.

Inside the transmission case there are three shafts, all parallel to each other. In the upper part of the case, directly in line with and to the rear of the center of the engine crankshaft, are the input and main shafts. Directly below the input and main shafts is the countershaft. The reverse idler shaft is a short shaft that is mounted off to one side of the main shaft and the countershaft.

At the front of the input shaft is a small part of the shaft called the pilot. The pilot fits into the pilot bearing in the center of the engine flywheel and supports the front of the input shaft. Just to the rear of the pilot is a splined area on the shaft. The clutch-driven disk mounts on this spline and provides the connection between the transmission and engine. To the rear of the spline is a long, smooth area of shaft that ends at a gear. This is the input drive gear that will be just inside the front of the transmission case when the shaft is mounted in position. To the rear of the input gear is another gear that will normally be of slightly different size than the input gear. This is the external gear portion of a synchronizer gear clutch. Both of the above gears are made as a part of the shaft. The rear of the input shaft is hollow. A smooth, round opening is machined into the rear of the shaft to mount a roller bearing. This bearing supports the front of the main shaft. The input shaft is supported in the proper position by a bearing at the front of the case.

Most transmissions use a large ball bearing to support the input shaft. The bearing is pressed onto the input shaft, and snap rings ensure that the bearing stays in the proper position on the shaft and in the case. A bearing retainer bolted to the front of the transmission case holds the input shaft bearing in position. The bearing retainer is usually a cast-iron flange with a long, tube-like sleeve extending forward from the center. In position, this sleeve is around, but not touching, the input shaft and provides a surface to mount the clutch release bearing.

The countershaft is mounted directly below and in line with the transmission input and main shafts. On heavier vehicles, this countershaft assembly is a series of gears of different sizes pressed on a steel shaft. Four or more gears are used with the largest at the front. The large gear on the front of the countershaft is in mesh with the input drive gear. On some three-speed transmissions, the countershaft gears from front to rear would be the drive gear, second speed, first speed, and reverse speed. Many transmissions use the same gear for both low and reverse. Countershaft bearings at the front and rear of the transmission support and align the shaft assembly within the case. On smaller transmissions the countershaft and gear may be made as two separate items. The countershaft on these transmissions is pressed into the case and held in position by a plate or pin, which prevents the countershaft from rotating or turning. The gears are forged as a single item and mounted on the shaft with roller bearings. This allows the gear to turn while the shaft remains still. This gear is sometimes called a "cluster gear."

The main shaft assembly is located to the rear and on the same center line as the input shaft. On the front of the shaft is a short pilot section that fits into the roller bearing in the rear of the input shaft. This is the front support for the main shaft. Located behind the pilot section of the shaft is a splined section that extends all the way to the rear end. Some shafts have a single size spline section while others have splines of several sizes along the main shaft. On some shafts, smooth machined surfaces are located between the splined areas along the shaft. These smooth surfaces are to mount gears that are not directly connected to the shaft. The design will depend upon the manufacturer.

Starting at the front of the main shaft of the simple three-sliding-gear transmission is the front gear, which will be the second-and-third speed gear. This gear is mounted upon a splined part of the main shaft so that it can be moved freely forward and backward. To the rear of the second-and-third speed gear is the first-and-reverse speed gear. This is also mounted on the splined part of the main shaft. The rear of the main shaft is supported by a large bearing, usually of the ball type which is mounted in the rear of the case. A cast-iron bearing retainer bolted to the rear of the case holds the bearing in position. The bearing retainer acts as a mount for an oil seal that rides against a smooth part of the main shaft. The seal prevents gear oil in the transmission case from escaping where the main shaft passes through the rear of the case. Outside the rear of the case, the main shaft has a splined and threaded section to mount a drive flange or yoke that is held in place with a large nut and cotter pin. Propeller shafts (drive shafts) connected to the flange or yoke at the rear of the transmission carry the engine power toward the rear of the vehicle.

Some military vehicles have an additional gearbox called a transfer assembly bolted to the rear of the transmission case. With this type of construction, the bearing retainer and drive flange are not used, since power flows directly into the transfer assembly.

OPERATION OF TRANSMISSIONS

Each manual transmission uses the same method to control the gears, but the construction will vary from model to model. The control lever may be mounted in the top of the cover and come up through the floor of the vehicle cab, or the lever may be mounted under the steering wheel on the steering column.

Tactical military wheeled vehicles use the top cover mounted control lever. Inside the transmission the shift control parts may be mounted in the top of the transmission case or in the cover assembly.

Most military vehicles have the shift mechanism mounted in the transmission cover. This method of construction provides easier repair and disassembly.

Two or more shifter shafts are placed in drilled passages in the cover and are in line with the main shaft. The shifter shafts can move forward, backward, or stay in the center-neutral position. With three positions, each shifter shaft can provide two transmission speeds along with the center-neutral position. Most three-speed-forward transmissions will have two shifter shafts in the control mechanism. Larger transmissions with more speeds must have additional shifter shafts.

To hold the shifter shaft in position, poppet balls and springs are mounted in passages drilled at right angle to the shifter shafts. The poppet ball spring pushes the steel ball into the detents or recesses in the shifter shaft to prevent movement. Three detents are made into the side of each shifter shaft, thus providing one for each shift position.

Mounted on each shifter shaft at the correct position is a shifter fork, which is held in place by a bolt or pin. The fork extends from the shifter shaft down into the case to fit into a groove made on a sliding gear. At the top of the shifter fork is a slot made to receive the lower end control lever.

The control lever is mounted in the transmission cover with a ball joint, allowing the control lever to be moved forward and backward or right and left. A pin at the ball joint prevents the lever from spinning in a circle. The upper part of the lever is outside of the transmission and extends into the vehicle cab.

Located between the shifter shafts and in line with the poppet balls and springs is an interlock device. The device is usually a ball or pin engaging notches in each shifter shaft and is able to slide sideways between the shifter shafts. This interlock device prevents two speeds from being engaged at the same time.

Learning Event 2:

DESCRIBE THE POWER FLOW AND LUBRICATION IN MANUAL TRANSMISSIONS

To increase the torque delivered by the engine, the transmission depends upon the basic principle of a small gear driving a large gear. The manual sliding-gear transmission provides several speed ranges by sliding different size smaller gears in and out of mesh with larger gears. To understand the complete operation, a three-speed-forward and single-reverse-speed transmission is presented below:

Anytime the clutch pedal is in the upper (released) position, the clutch is engaged. At this time, the clutch disk is locked between the driving members of the clutch assembly. With the clutch disk splined to the input shaft of the transmission, there is a direct mechanical connection from the engine to the transmission.

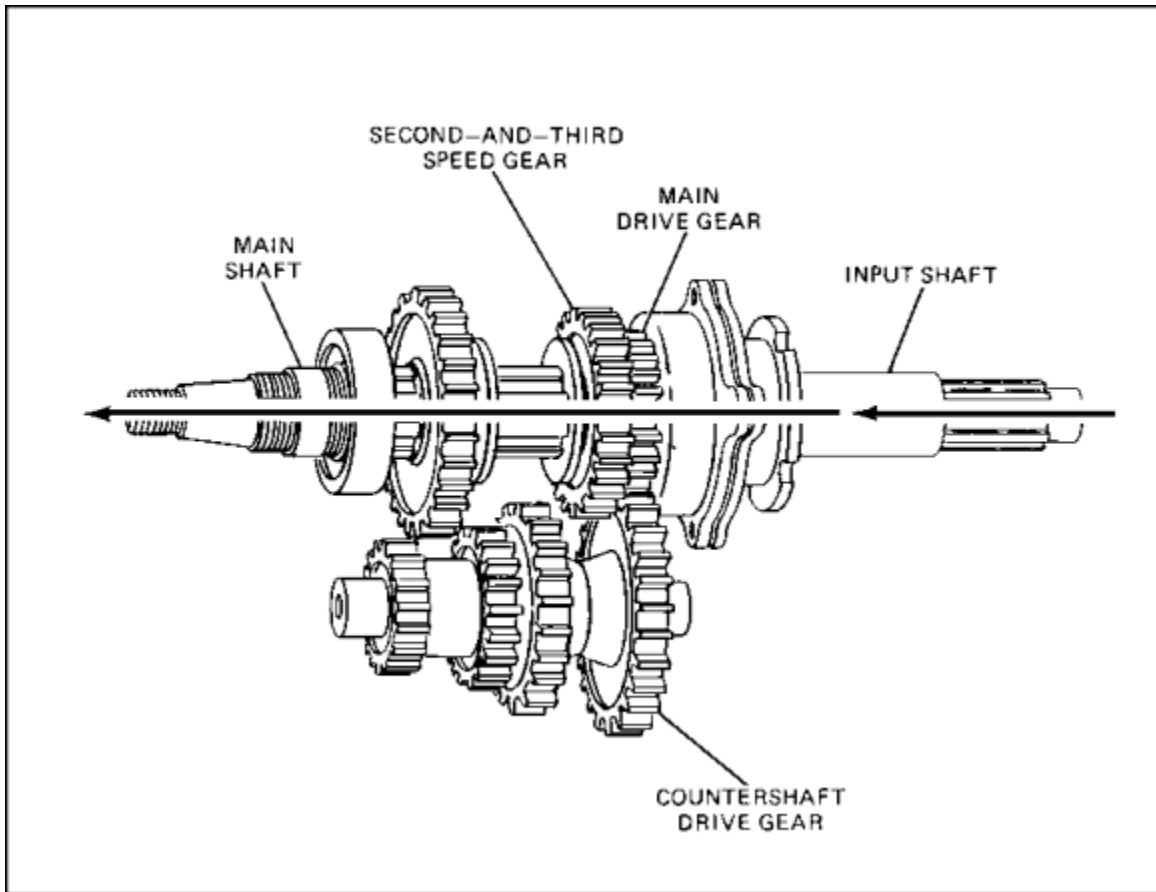

FIGURE 10. TRANSMISSION GEARS IN HIGH POSITION.

Power flow is from the engine to the transmission input shaft which turns at the same speed as the engine. Since the countershaft drive gear is always in mesh with the input shaft main drive gear, it will also be turning, but in the opposite direction from the main drive gear on the input shaft.

The input gear is slightly smaller than the countershaft drive gear; therefore, the countershaft gear will turn slower than engine speed or at a reduction.

The two sliding gears on the main shaft are not in mesh with any of the gears on the countershaft in neutral speed. With no main shaft gears in mesh with the countershaft gears, there is a break in the power flow path. Power flow will end at the countershaft. When the vehicle operator desires to place the transmission in first speed, the first step is to release the clutch disk.

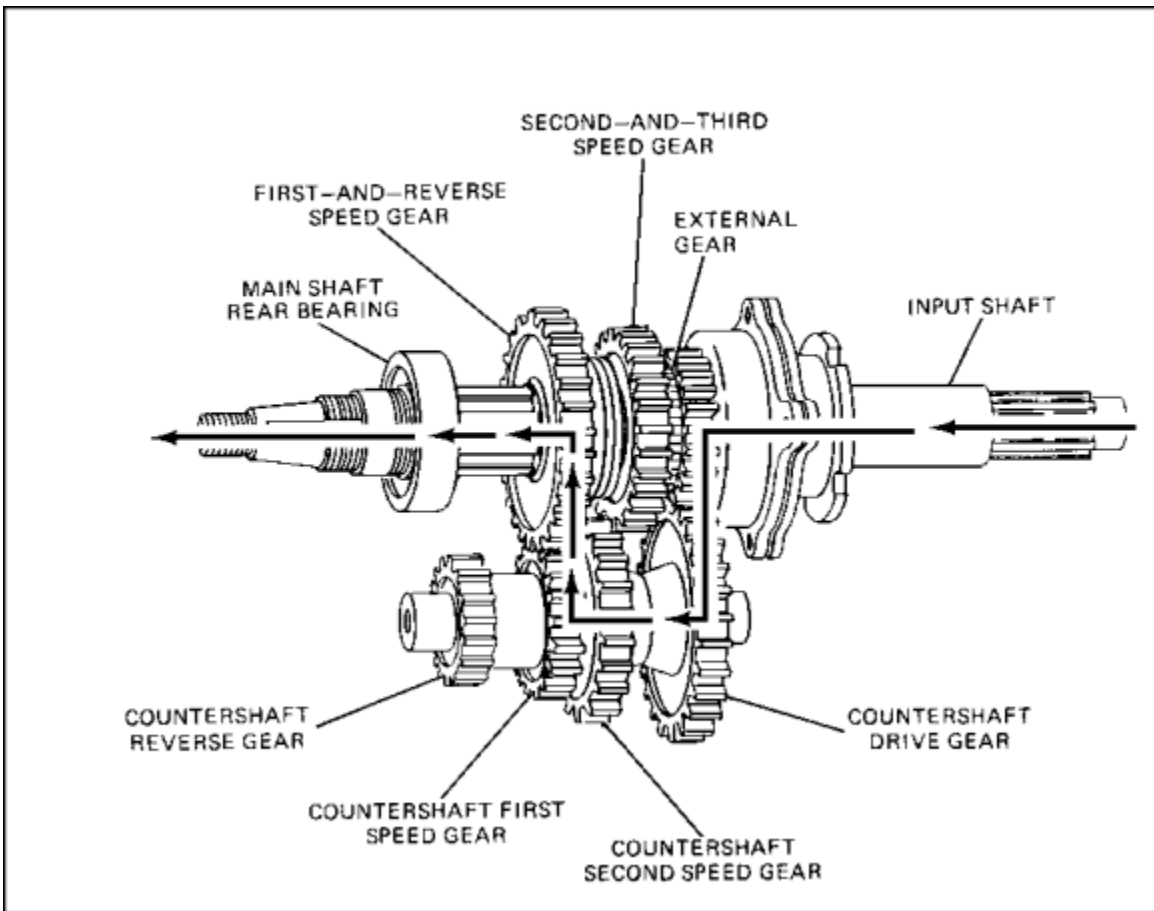

FIGURE 11. TRANSMISSION GEARS IN LOW POSITION.

With the clutch pedal down and the input shaft not turning, the transmission control lever is moved into the first-speed position. As the top of the control lever is moved to the rear, the bottom of the lever inside the transmission is moving forward. The lower end of the lever forces the first-and-reverse shifter shaft, fork, and gear to move forward. The first and reverse speed gear slides along the spline of the main shaft and into mesh with the first-speed gear on the countershaft.

When the vehicle operator releases the clutch pedal, the clutch is engaged and the transmission is driven in first speed. Power flows from the engine to the input shaft, countershaft, main shaft, and out of the rear of the transmission. The small input drive gear is driving the larger countershaft drive gear; therefore, an increase in power is obtained. A second increase in power is gained with the smaller gear on the countershaft driving the larger first-and-reverse speed gear on the main shaft. Since the first-and-reverse gear is splined to the main shaft, a double increase in power is delivered to the main shaft for transmission output. The direction of rotation (turning direction) changes twice in the power path. When two external gears are placed in mesh and turned, each will turn in a different direction. When looking at the transmission from the front, the input shaft will be driven in a clockwise direction by the engine. This will force the countershaft to turn in the opposite direction or counterclockwise. As the countershaft gear drives the gear on the main shaft, the main shaft will be forced to turn clockwise, which is the same as the input shaft.

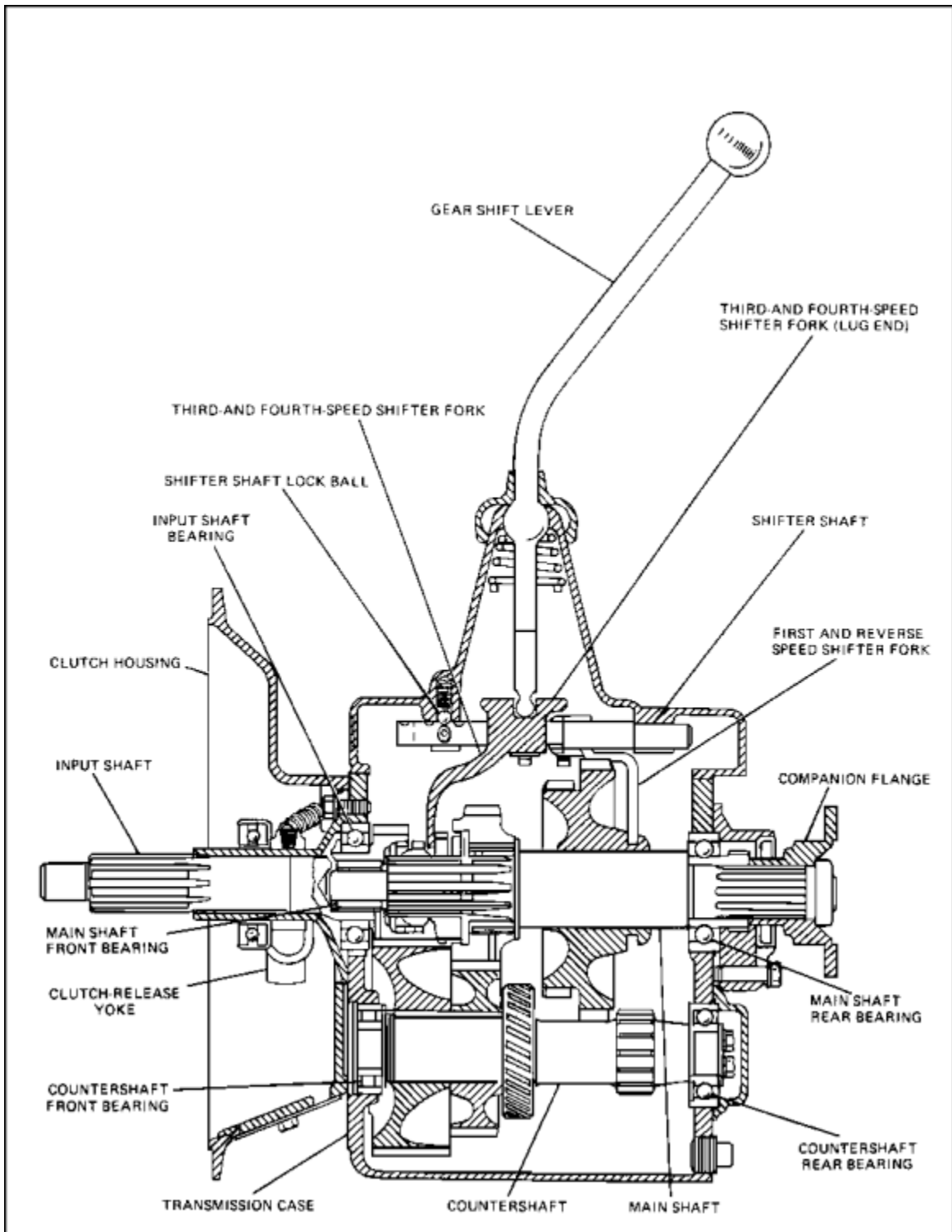

FIGURE 12. CONSTANT-MESH TRANSMISSION ASSEMBLY.

The shift to second speed is normally made with the vehicle in motion, and the shift is directly from first to second speed.

In the vehicle cab, the operator releases (disengages) the clutch and moves the shift lever from the first, through neutral, and to the second-speed position. Inside the transmission case, the lower end of the shift lever forces the first-and-reverse speed shifter shaft, fork, and gear to move rearward to the neutral position. When the neutral position is reached, the shift lever moves out of the first-and-reverse speed shifter fork slot and sideways into the slot of the second-and-third speed shifter fork. The second-and-third speed gear is forced to slide to the rear along the main shaft spline until it is in mesh with the second-speed gear on the countershaft. When the proper position is reached, the steel poppet ball is pushed into the detent on the shifter shaft by spring pressure to hold the gears in mesh.

The vehicle operator engages the clutch, and power flows into the input shaft, countershaft, and second-speed gears and then out the main shaft. An increase in power is gained from the input to countershaft. There is very little difference in the size of the second-speed gear on the countershaft and the second-and-third speed gear on the main shaft that it drives. With these gears nearly the same size, there will only be a slight change in engine torque. A larger increase is not needed at the second speed gears because enough power increase is gained between the input and countershaft drive gear for the second speed. The total increase in engine torque is not as great in second speed as with first speed; therefore, output speed is greater. The power flow is into the input shaft, to the countershaft, and to the main shaft through the gearing.

To shift the transmission from second to third speed, the vehicle operator releases (disengages) the clutch and moves the shift lever from second to third position.

As the lever moves to the rear at the top, it pivots or turns on the ball joint in the top of the cover, and the bottom of the lever moves forward inside the case. The bottom of the shift lever forces the second-and-third speed shifter shaft, fork, and gear to move forward. As the second-and-third speed gear slides forward along the spline of the main shaft, it moves out of second speed, through neutral, and into third-speed position. The poppet ball and spring hold the gears in the proper position. As the second-and-third speed gear moves forward to the third position, its internal teeth mesh with the external gear at the rear of the input shaft and locks the input shaft to the main shaft. The internal-type gear, inside the front of the second-and-third speed gear, together with the external gear on the rear of the input shaft, form a gear clutch.

With the input and main shafts locked together, power from the engine flows in the input shaft and out the main shaft when the clutch is engaged. The countershaft will be driven during this speed, but the shaft will transfer no power. In third speed, which is a direct drive in the three-speed-forward transmission, there will be no increase in engine torque or twisting force.

The wheeled vehicle should not be moving when the transmission gears are shifted from neutral to the reverse speed. The operator releases (disengages) the clutch and moves the control lever from neutral to reverse position. The bottom of the control lever forces the first-and-reverse speed shifter shaft, fork, and gear to move to the rear.

As the first-and-reverse gear moves to the rear, it will mesh with the reverse idler gear that is mounted to one side of the main and countershafts. The reverse idler gear is in mesh with both the first-and-reverse sliding gear on the main shaft and the reverse gear on the countershaft.

During all of the transmission forward speeds, the output shaft turns in the same direction as the input shaft. To drive the output shaft in the opposite direction of the input shaft, an additional gear must be placed in the gear train. This is the reverse idler gear. When looking at the transmission from the front, the input shaft turns clockwise, the countershaft turns counterclockwise, the reverse idler gear turns clockwise, and the first-and-reverse gear and main shaft turn counterclockwise. Each of the driving gears in this train is smaller than the driven gears, thus a larger increase in torque is gained in reverse speed. Anytime a small and large gear are used to increase power in a gearbox, it is necessary to give up speed or revolutions (turns) per minute. More engine power is delivered to the vehicle wheels in reverse than in any other shift position, but the vehicle will travel slower than in forward speeds.

Each shift has a detent or recess in the shaft in line with the interlock device when in the neutral position. Recall that the interlock device is usually a ball or pin engaging notches in each shifter shaft. When one of the shifter shafts is moved from the neutral position, the recess for the interlock moves out of line with the device passageway. The moving shaft forces the interlock device to slide to the side and into the recess on the opposite shifter shaft. This action locks the shaft in the neutral position. The shifter shaft that was moved from neutral blocks the interlock device to prevent movement of the other shaft until both shafts are once again in the neutral position.

When the transmission has three shifter shafts, two interlocks must be used to ensure that only one shaft moves at a time. This prevents the transmission from being placed in more than one gear at a time. Placing the transmission in more than one speed can cause a locked or jammed gearbox. When power is applied, the gearbox could be damaged or destroyed.

LUBRICATION

The lower part of the transmission case contains gear oil, the amount of which is determined by the level plug in the side of the case. This oil in the bottom of the case covers much of the countershaft gear assembly. When the transmission is in operation and the countershaft gear is turning, oil is thrown by the gear over the entire inside of the case. Oil seals at the input and output shafts prevent oil from leaking out of the case. Some transmissions use metal plates called oil slingers in front of the shaft bearings to direct oil back to the center of the case. The lubricating oil reaches difficult places by way of drilled passages in gears and shafts.

VENTILATION

When a gearbox is placed into operation, the friction of the working parts generates enough heat to warm the entire item. As the component heats up, the air inside the case expands. If some means is not provided to let expanding air escape from the gearbox, high pressure will be present in the case. Too much pressure inside the case will force the lubricating oil past the oil seals to the outside and possibly damage the seals. A vent assembly is installed in the top of the gear cases to allow excess pressure to escape.

CONSTANT MESH TRANSMISSIONS

Early model sliding-gear transmissions were very difficult to shift from one gear to another and were very noisy during operation. Hard shifting was improved by using constant-mesh gearing. Gears mounted on the main shaft are placed in mesh with the matching gears on the countershaft. This causes the constant-mesh gears on the main shaft to be driven anytime the transmission is in operation.

All main shaft constant-mesh gears will have to be of the free running type. These gears are mounted on the main shaft by means of a bearing rather than with splines. With this type of mounting, there is no direct mechanical connection between the constant-mesh gears and the main shaft, and the gears can run free when not in use. Gears that run free on the main shaft are connected to the shaft by means of a sliding-gear clutch. The sliding gear of the gear clutch is mounted on splines on the main shaft and allowed to move backward and forward.

When the transmission control is moved, the sliding gear moves into mesh with one of the constant-mesh gears on the main shaft. This gear then drives the main shaft through the gear clutch.

To reduce the noise of the moving gears during operation, helical gears are used in place of the straight-tooth spur gears. On the helical gear, the teeth are placed on an angle across the face of the gear. This construction causes the gear teeth to slide into mesh with less noise. A disadvantage of helical gears is that the angle of the teeth tends to cause the gears to move endwise on their shaft, producing thrust under a load. When helical gears are used in a gearbox, thrust washers or bearings are installed to control the end thrust of the gears.

SYNCHROMESH TRANSMISSIONS

Hard and noisy shifting is caused by the clashing of two gears brought together while turning at different speeds. The constant-mesh gear, clutch-type transmission improved the early sliding-gear model, but there was still some shifting noise. A synchronizer assembly was added to the constant-mesh-type gearbox to remove all gear clash when shifting gears.

The synchronizer is a friction device which causes two gears to turn at the same speed before they are brought into mesh. When two gears are brought into mesh that are turning in the same direction at the same speed, there is no gear noise. Small cone clutches made into the synchronizer assembly are applied before the teeth of the sliding gear and the main gear come in contact. A simple synchronizer consists of a hub and sleeve. The hub is mounted on the main shaft by means of a spline that allows the assembly to move forward and backward. A sleeve is splined to the outside of the hub and is able to slide on the hub. The hub and sleeve are held together in the neutral position by detent balls under spring pressure. The detent balls and springs are mounted in passages drilled in the center of the synchronizer hub, and the balls seat in the detent or groove on the inside of the center of the sleeve. Inside of the inner edges of the hub are bronze cone clutch friction surfaces.

The gears mounted to the front and rear of the synchronizer assembly have smooth, steel-cone surfaces that face the matching bronze cones of the synchronizer.

Most synchronizer assemblies are designed to operate either to the front or rear for two transmission speeds or remain in the center position for neutral. In the neutral position, the hub is in the center of the gears to the front and rear, while the sleeve is centered over the hub.

As the vehicle operator moves the control lever, the shifter shaft and fork move the synchronizer sleeve toward the gear to be engaged. With the poppet balls and springs holding the hub and sleeve together under spring pressure, the entire assembly slides toward the gear. The first part of the synchronizer to contact the gear is the bronze-cone clutch surface. As the cone clutch surfaces of both the synchronizer and gear come together, the speed of the two items is made the same.

The vehicle operator continues to apply pressure on the transmission control lever, and the sleeve of the synchronizer is forced to override the poppet balls and slide along the top of the hub toward the gear. The sleeve slides in mesh with a small external gear made as part of the transmission constant-mesh gear. This action locks the synchronizer assembly to the constant-mesh gear. Power is then delivered from the constant mesh gear to the synchronizer assembly, to the main shaft, and out the rear of the transmission.

Learning Event 3:

DESCRIBE THE CONSTRUCTION AND OPERATION OF POWER TAKE-OFFS

Military vehicles often mount special equipment that is driven by the vehicle engine. Examples of vehicles with special equipment are wreckers, dump trucks, tankers, and trucks with winches. To obtain the power to drive a winch or pump, a connection must be made into the vehicle power train. This is done with a gearbox called a power take-off (PTO) assembly, which is bolted to a larger gearbox such as the transmission, auxiliary transmission, or transfer assembly. The PTO gets power from the larger gearbox as needed to drive the special equipment. Many models of PTO assemblies are in use on military equipment, and the size and number of speeds will depend upon the item to be driven.

The most simple PTO assembly is the single-speed, single-gear type. This assembly will drive an item of special equipment in one direction at one speed. Larger PTO assemblies may have several forward and reverse speeds and may drive two or more pieces of special equipment.

CONSTRUCTION AND OPERATION

The construction and operation presented here is based on a single forward-and-reverse speed PTO for driving a vehicle front winch. This assembly has a forward, reverse, and neutral shift position.

A cast-iron case provides the housing and mounting for all of the shafts and gearing of the assembly. A large, flanged opening on the side of the gearbox provides the mounting surface. The mounting flange will match the mounting surface made on the side of the transmission or transfer assembly that is to mount the PTO. Machined openings in the front and rear of the case provide mounting points for the shafts. Some cases contain a drain plug for the lubricant.

All shafts in the gear case are mounted in line with the vehicle power train or from front to rear of the vehicle. Output shafts may extend outside the front or rear of the PTO case. Those driving the front winch will extend from the front. Tapered or straight roller bearings may be used to mount shafts in the case. Shift shafts are made to slide forward and rearward in a drilled passage in the case as in the manual transmission. The shifter fork is bolted or pinned to the shifter shaft, and a recess or detent is made into the shifter shaft for each shift position. A steel ball under pressure is mounted in a passage at a right angle to the shifter shaft and fits into the recesses.

The PTO idler gear is mounted very near the large flange on the side of the case. This method of mounting causes the idler gear to extend outside the PTO case. When the PTO is bolted to a transmission or transfer, the idler gear extends into the larger gearbox to mesh with a driving gear. The idler gear is a double gear with two sets of gear teeth. One set of gear teeth is designed to mesh with a drive gear in the transmission, and the other will mesh with the reverse gear. The reverse gear is a double gear that is mounted to one side and is in constant mesh with the idler gear. Straight roller bearings are used to mount the reverse gear to the shaft. The sliding gear, which is made to mesh with both the idler reverse gears, is mounted on the spline of the output shaft. Tapered roller bearings at each end mount (support) the output shaft in the PTO case. The sliding gear can slide to the front or rear on the output shaft. A part of the output shaft extends to the outside of the case. An oil seal and retainer prevents loss of lubricating oil where the output shaft passes through the case. A propeller shaft drive yoke is mounted on the end of the output shaft, outside the PTO case, and is secured by a metal key which fits into a slot in the shaft.

When the PTO is mounted on the side of the transmission, the shift lever extends up into the cab of the vehicle.

A slot cut into the cab floor allows the lever to be moved back and forth.

A latch for holding the lever in the neutral position, when the PTO is not in use, is mounted to the cab floor.

In the neutral position, the PTO idler gear is in constant mesh with a gear on the transmission countershaft. The PTO reverse gear is in constant mesh with the idler gear. The sliding gear is in the neutral position between the idler and reverse gears. When the vehicle clutch is engaged by the operator, the transmission countershaft will drive the idler and reverse gears of the PTO. Since the sliding gear is not in mesh with any driving gear, no power reaches the output shaft.

Now let's see what happens when a PTO used to operate a winch is put into operation.

To wind in the cable, the vehicle operator releases (disengages) the clutch and moves the PTO control lever. As the top of the shift lever moves forward, the lever pivots on the mounting pin and the lower end of the lever moves rearward. The shift shaft, which is connected to the lower end of the control lever, moves to the rear. At the same time, the shift fork mounted on the shift shaft is moving the sliding gear inside the PTO to the rear. The sliding gear moves along the splines of the output shaft into mesh with the idler gear. When the shift is complete, the steel ball under spring pressure moves into the recess on the shift shaft to hold the gears in position. As the engine clutch is engaged, the transmission countershaft drives the PTO idler gear, sliding gear, and output shaft. The output shaft drives the winch propeller shaft in the proper direction to cause the winch to wind in the cable.

To drive the winch so that the cable will unwind from the drum, the vehicle operator releases the engine clutch and moves the PTO control lever to the rear. This forces the shifter shaft, fork, and sliding gear to move forward so that the gear meshes with the reverse gear. The steel ball under spring pressure holds the shifter shaft in the selected position. As the engine clutch is engaged, the transmission countershaft drives the idler, reverse, and sliding gears. Since the sliding gear is splined to the output shaft, the shaft is driven in the same direction as the gear. The winch propeller shaft is driven by the output shaft in the proper direction to unwind the cable from the winch drum.

PTO assemblies mounted low on the side of a larger gearbox are below the level of the lubricating oil. This construction allows the transmission lubricant to flow freely in and out of the PTO. Proper lubrication is assured for all PTO parts in operation below the level of the gear oil. On those PTO assemblies mounted above the level of the lubricant, oil is splashed into the assembly by the transmission countershaft.

The heavy-duty-type PTO is designed to mount on a standard six-hole or six-stud PTO opening and is designed to mount on the left or right side of the driving mechanism. The shifter shaft extends through each end of the case so that the shifting control linkage may be attached at either end. The output shaft extends from the front of the case and is provided with a woodruff key for mounting the winch propeller shaft companion flange. Boots are installed over the ends of the shifter shaft to protect the surface of the shaft. The PTO input gear is a cluster composed of a helical gear, which is constantly in mesh with the helical gear of the transmission reverse idler gear, and the driving gear, which is of spur-tooth construction.

The PTO has two forward speeds, neutral, and one reverse speed. A shifting mechanism provides selection of the desired speed and direction of rotation of the output shaft. The neutral position of the shifting mechanism disengages the output shaft gears from the driving gear.

INPUT GEAR

The helical input gear is in constant mesh with the helical gear of the transmission reverse idler gear and is therefore in constant rotation when the engine is engaged. The input gear is installed on a nonrotating input gearshaft and is mounted on the input gear roller bearings. The shaft is pressed into the housing and secured with a cotter pin. A thrust washer is located at each end of the input gear. The helical-tooth portion of the input gear is in constant mesh with the reverse gear which is installed on the reverse gearshaft and secured with the reverse gear pin. The reverse gearshaft rotates in two supporting roller bearings.

OUTPUT SHAFT

The output shaft is supported in the housing on two ball bearings. Two gears are installed on the output shaft. One is the output shaft sliding gear which is moved forward and backward on the shaft by the shifter fork. The other is the output shaft high-speed gear which is free on the output shaft and is in constant mesh with the input gear. The sliding gear is splined to the output shaft and may mesh with the reverse gear spur teeth, with the spur teeth on the input gear for low-speed operation, or it may act as a clutch gear to couple the output shaft high-speed gear to the output shaft.

SHIFTER FORK

The shifter fork is attached to the shifter shaft by means of a cap screw. The fork engages the circumferential groove on the sliding gear.

Learning Event 4:

DESCRIBE THE MAINTENANCE OF MANUAL TRANSMISSIONS AND POWER TAKE-OFFS

This lesson will acquaint you with procedures to be followed when inspecting, testing, adjusting, or repairing transmissions and PTOs.

Remember, however, you should never be satisfied with just finding and correcting the trouble. You should always try to find what caused the trouble. If you find a transmission with broken gear teeth, don't be satisfied with just replacing the transmission. Try to find out what caused the gear teeth to break.

Whenever you find such components as the transmission and PTO in an unserviceable condition, talk to the driver. The driver may be able to explain exactly how the failure occurred and give you a clue as to the cause of the failure.

If you fail to find the cause, you will probably have to do the job over because the same trouble will most likely develop in the replacement transmission or PTO.

INSPECTING THE TRANSMISSION

Leaking oil seals and gaskets are probably the most common causes of transmission and PTO problems. If such problems are not corrected in time, the gears, shafts, and bearings can be ruined.

There are many possible causes for oil seal or gasket failures, so always look for causes whenever you find such failures.

CAUSE OF LEAKING LUBRICANTS

Now let's discuss some of the reasons why the lubricant is likely to leak at any one or several of these locations. First of all, a transmission (or almost any other gear case) will usually start leaking if the oil level is too high. To stiffen the oil used in gear cases, soap and soda are usually added to the oil. As the gears operate, the oil is splashed all over the inside of the gear case. Because of the soap and partly because of the splashing and the heat, the oil starts to foam or fill with air bubbles. Thus, the oil expands and takes up more room. This action creates excessive pressure inside the gear case. If the oil level is too high to start with, the pressure created inside the transmission may be more than the seals and gaskets can resist and the oil will start leaking out. Leaking can occur at any one or several locations.

The transmission oil level should only be checked after the vehicle has been parked for several hours or overnight. During this time, the bubbles or foam will cool and settle as a liquid in the bottom of the transmission case.

With the transmission cold, remove the fill plug. The oil level should be at, or just below, the bottom of the fill plughole.

If the oil level is too high, allow the excess oil to run out the fill plughole.

Even if the oil level is correct, it is possible that the foaming action of the oil will cause the pressure inside the transmission to become too high. To permit the excess pressure to escape, a vent valve is used. This valve contains a seat and a spring-loaded ball and has a dust cap over the valve assembly. To check the vent valve, first ensure the area around it is free of dust and dirt. Then try turning the dust cap with your fingers. It should turn freely in either direction. If it does not turn freely, replace it.

Gaskets or oil seals will always leak if the bolts securing the plates, covers, or retainers are loose. All of the bolts should be tightened uniformly with a torque wrench.

The bolts that secure the input shaft retainer, the gearshift housing cover, and the retainer seals are all 5/16-inch bolts and should be tightened with a torque wrench to 10 to 14 pound-feet. Do not overtighten.

The bolts that secure the transfer case to the transmission are 3/8 inch and should be tightened to 20 to 25 pound-feet. If tightening the bolts fails to stop a leak at this point, the using unit repairer should notify the motor officer or motor sergeant, because replacing the transmission or transfer case gaskets is a job for a maintenance support unit.

Leaks around the threads of the fill plug, the drain plugs, or any of the bolts can usually be stopped by coating the threads of the plugs or bolts with a lead-based paint.

A loose gearshift retainer will also allow the lubricant to escape.

If there are leaks that cannot be stopped by tightening the bolts and plugs, or by coating the threads, notify your maintenance support unit.

All of the seals need to be lubricated; otherwise, they will be ruined. Therefore, a little seepage around any seal is normal. A seal is not considered as leaking unless enough oil is escaping by the seal to drip on the ground and cause a small puddle.

LEAKING SEALS

With the power plant in the vehicle, you can inspect all seals except the input shaft retainer seal. If this seal is leaking, oil will drip out through the plughole in the bottom of the pan under the flywheel housing when the plug is removed.

If oil does drip out at the flywheel housing drain plug, examine the oil closely. It may be engine oil leaking from the engine crankshaft rear oil seal. The engine oil is much thinner (has less viscosity) than the transmission oil, so you should be able to tell which seal is leaking.

An oil leak, either from the engine or transmission input shaft seals, is serious, because the oil can ruin the clutch. An oil-soaked clutch disk will almost always slip or grab.

TESTING TRANSMISSIONS FOR MALFUNCTIONS

In addition to the leakage problems, there are other problems that can develop in the transmission used in the 1/4-ton truck. We can classify these as mechanical problems.

The best way to locate mechanical problems in the transmission is to road test the vehicle. Before road testing, however, check for missing or loose bolts and be sure the oil is at the proper level in the transmission case. Check the parking brake mechanism for proper mounting and correct adjustment. Check all moisture seals or boots. Check the action of the gearshift levers.

The transmission is often blamed for problems that are elsewhere. For example, with the engine running and the vehicle standing still, disengage the clutch and move the gearshift lever into first or reverse. You should be able to shift into either of these gear positions without any gear clashing or without the vehicle moving. If the gears clash or the vehicle attempts to move with the clutch disengaged, the trouble is in the clutch and not the transmission.

Check the clutch pedal free travel and adjust if necessary. The clutch must be correctly adjusted before the transmission can operate properly. The clutch must fully disengage every time the clutch pedal is pushed all the way down and fully engage every time the pedal is released.

With the transmission in neutral, the engine running, and the clutch engaged, all of the constant-mesh gears in the transmission will be turning. There should be very little gear or bearing noise.

If the transmission is quiet in neutral with the clutch engaged, disengage the clutch. If a noise is now heard, the trouble is with the clutch and not the transmission. Usually, the clutch release bearing or the clutch shaft pilot bearing is at fault if a noise is heard only when the clutch is disengaged.

Sometimes, noises in other parts of the power train, such as U-joints, propeller shafts, and differentials, sound as if they are in the transmission. Misalignment of power train components usually produces a noise that may sound as if it is coming from the transmission. So be sure to check all mounting bolts on the engine, transmission, and differentials before road testing the vehicle. Also check the propeller shafts and U-joints for evidence of wear or looseness.

Loose, bent, or shifted suspension system components will cause misalignment of the power train components which can produce a noise that may sound like a defective transmission.

Noises that may originate in the transmission are difficult to describe. A noise that may sound like a howl to you may sound like a squeal to someone else. Other terms often used to describe gear or bearing noises may include such words as "hum," "knock," "grind," "whine," and "thump."

If a tooth is broken off of one of the gears, a distinct thumping noise will be heard once during a complete revolution of the gear. The thump will be more pronounced if torque is being delivered through that gear.

Gears with worn, rough teeth will usually produce a grinding noise, especially when torque is being transmitted through them.

Bearing noise is usually described as a howl, whine, or squeal. Actually, the type of noise made by a defective bearing will vary, depending on the type of defect and the load the bearing is supporting. In any event, loud noises coming from inside of the transmission mean trouble.

Some whine or grinding noise can be expected, especially when the vehicle is being driven in first or reverse gear. The first-and-reverse sliding gear together with its mating countershaft gear and reverse idler gear are spur gears. Spur gears are always noisy, but, as you recall from a preceding lesson, they are frequently used because they are cheaper and do not produce thrust.

In the second-, third-, and fourth-speed ranges, the transmission should be much quieter than in first or reverse.

If, after a road test, you think the transmission is too noisy, be sure and report it to the motor sergeant. Be sure to describe the conditions under which the noise occurs.

Another common mechanical problem with transmissions of this type is slipping or jumping out of gear. Actually, the transmission is much less likely to slip or jump out of first or reverse than out of the second-, third-, or fourth-speed gear. Second-, third-, and fourth-speed gears are all helical gears which, you recall, produce thrust.

The most likely causes of the transmission slipping out of gear are worn detent balls or springs in the shifter shaft cover. These spring-loaded balls hold the shifter shaft in position, and if the spring doesn't have enough tension, or if the balls are worn, the transmission will almost certainly slip or jump out of gear. Synchronizer damage will also cause the transmission to jump out of gear.

Slipping out of any gear is most likely to occur when the driver suddenly takes his/her foot off of the accelerator pedal-especially when descending a steep hill. The thrust produced by the helical gears will tend to move all rotating gears and shafts to the rear of the transmission, as long as the torque provided by the engine is being delivered to the rear wheels by the transmission. However, when the driver takes his/her foot off of the accelerator pedal, the situation is changed. The rear wheels now try to drive the engine through the transmission. This reverses the direction of the torque being delivered through the transmission gears, and the thrust is now toward the front of the transmission. If this thrust is not controlled by the thrust washers and bearing retainers, it is likely to force the shifter shaft to move in spite of the spring-loaded ball that holds it. When this happens, the transmission slips out of gear.

Occasionally, a transmission slips out of gear because the driver does not fully engage the gear when moving the lever. However, a transmission that slips out of gear fairly often should be replaced.

POWER TAKE-OFF MAINTENANCE (Inspecting and Testing)

Specific procedures must be followed when inspecting, testing, and servicing the PTO and related parts.

On military vehicles, PTOs are commonly used to drive winches. The winches are usually mounted on the front of the vehicles, although some vehicles, such as wreckers, also have winches mounted at the rear. In the case of the wreckers, separate PTOs are used to drive each winch.

The procedures for inspecting and testing PTOs are similar to those followed when inspecting and testing the transmission.

The input gear of the PTO used to drive the front winch on a 2 1/2-ton truck is in constant mesh with the reverse idler gear on the transmission countershaft. The PTO input gear and driving gear are turning anytime the engine is running and the clutch is engaged. They are also turning if the vehicle is moving. Therefore, worn or broken PTO input or driving gear teeth, or defective bearings, can cause noises that sound as if they are coming from the transmission.

Leaking PTO gaskets or seals will also cause a loss of transmission oil, because the PTO is bolted to the transmission and is lubricated by the oil from it.

The most likely places for oil leaks from the PTO are the mounting flange gasket between the PTO and the transmission; the PTO cover, cap screws, and cover gasket; the poppet ball retainer; the output and reverse shaft rear bearing cap; the output shaft bearing cap, gasket, and seal; and the bellows-type boots or seals at both ends of the shifter shaft.

Any of the leaks around the mounting flange, bearing caps, or cover gaskets may be corrected by tightening the mounting screws or nuts to the proper torque. If tightening the screws and nuts fails to stop the leaks, notify your support maintenance unit. Replacing the seals is also a job for the support maintenance unit.

PRACTICE EXERCISE

1. What type of gears are used in the manual transmission to make it quieter?
 - a. Bevel
 - b. Straight spur
 - c. Helical

2. Most manual transmission gear cases are constructed of
 - a. cold-rolled steel.
 - b. cast iron.
 - c. forged steel.

3. What part of the conventional transmission prevents shifting into two gears at the same time?
 - a. Interlock device
 - b. Poppet ball
 - c. Synchronizer

4. If the transmission is quiet in neutral with the clutch engaged, but noisy when the clutch is disengaged, the trouble is probably in the
 - a. synchronizer clutch.
 - b. drive gear.
 - c. release bearing.

5. A vehicle should be parked several hours before checking the transmission oil level to permit the
 - a. oil to cool and shrink.
 - b. foam to cool and settle.
 - c. pressure to escape.

Lesson 3

ANSWERS TO PRACTICE EXERCISE

1.c (page 48)

2.b (page 35)

3.a (page 39)

4.c (page 57)

5.b (page 55)

**LESSON 4
FUNDAMENTALS OF AUTOMATIC TRANSMISSIONS**

TASK

Describe the fundamentals of automatic transmissions.

CONDITIONS

Given information on the operation, drive train, and hydraulic system of the automatic transmission.

STANDARDS

Answer 70 percent of the multiple-choice items covering fundamentals of automatic transmissions.

REFERENCES

TM 9-8000

Learning Event 1:

DESCRIBE THE OPERATION AND DRIVE TRAIN MECHANISMS OF THE AUTOMATIC TRANSMISSION

DESCRIPTION

The automatic transmission, like the manual transmissions, matches load requirements of the vehicle to the power and speed range of the engine. This is done automatically depending on throttle position, vehicle speed, and the position of the shift control lever. Automatic transmissions are built-in models that have two, three, or four forward speeds, and some are equipped with overdrive. Operator control is limited to the selection of the gear range by moving a control lever.

COUPLING

The automatic transmission is coupled to the engine through a torque converter. The torque converter is used with an automatic transmission, mainly because it does not have to be manually disengaged by the operator each time the vehicle is stopped. Because the automatic transmission shifts without any interruption of engine torque application, the cushioning effect of the fluid coupling within the torque converter also is desirable.

SHIFTING

Because the automatic transmission shifts gear ratios independently, it must do so without the operator releasing the throttle. It does this by using planetary gearsets whose elements are locked and released in various combinations that produce the required forward and reverse gear ratios. The locking of the planetary gearset elements is done through the use of hydraulically actuated, multiple-disk clutches and brake bands. The hydraulic pressure that actuates these locking devices is controlled by the valve body. Think of the valve body as a hydraulic computer that receives signals indicating vehicle speed, throttle position, and gearshift lever position. Based on this information, the valve body sends hydraulic pressure to the correct locking devices to produce the required gear ratios.

OPERATOR CONTROLS

The only operator control for an automatic transmission is the gearshift lever, although the accelerator pedal also can be considered an operator control, because it forces the transmission to shift to a lower ratio when it is fully depressed.

DRIVE TRAIN MECHANISMS

Multiple-Disk Clutch

The multiple-disk clutch, in most cases, is used to transmit torque by locking elements of the planetary gearsets to rotating members within the transmission. In some cases, the multiple-disk clutch also is used to lock a planetary gear set element to the transmission case so that it can act as a reactionary member.

Construction

The multiple-disk clutch is comprised of the following components:

Disks and Plates

The active components of the multiple-disk clutch are the disks and the plates. The disks are made of steel and are faced with a friction material. They usually have teeth cut into their inner circumference to positively key them to the clutch hub. The plates are made of steel with no facing, and usually have teeth cut into their outer circumference to positively key them inside of a clutch drum or to the inside of the transmission case. By alternately stacking the disks and plates, they are locked together or released by simply squeezing them.

Clutch Drum and Hub

The clutch drum holds the stack of disks and plates and usually is attached to the planetary gearset element that is being driven. The clutch hub usually attaches to the driving member and fits inside of the clutch disks and plates.

Pressure Plate

The pressure plates are thick clutch plates that are placed on either end of the stack. Their purpose is to distribute the application pressure equally on the surfaces of the clutch disks and plates.

Clutch Piston

The clutch piston uses hydraulic pressure to apply the clutch. Hydraulic pressure usually is supplied to the clutch piston through the center of the rotating member.

Clutch Piston Seals

The clutch piston seals serve to prevent the leakage of hydraulic pressure around the inner and the outer circumferences of clutch piston.

Clutch Springs

The clutch springs ensure rapid release of the clutch when hydraulic pressure to the clutch piston is released. The clutch springs may be in the form of several coil springs equally spaced around the piston or one large coil spring that fits in the center of the clutch drum. Some models use a diaphragm-type (Belleville) clutch spring.

Operation

Now let's discuss the operation of a multiple-disk clutch.

When the clutch is released, there is no hydraulic pressure on the clutch piston, and the clutch disks and plates are free to rotate within each other. The result is that the clutch hub rotates freely and does not drive the clutch drum.

When the clutch is applied, hydraulic pressure is applied to the clutch piston which, in turn, applies pressure to the clutch disks and plates, causing them to lock together. As a result, the clutch hub drives the clutch drum through the clutch.

Brake Band

The brake band is used to lock a planetary gearset element to the transmission case so that the element can act as a reactionary member.

Construction

The brake band is comprised of the following components:

Band

The brake band is a circular piece of spring steel that is rectangular in cross section. Its inside circumference is lined with a friction material. The brake band has bosses on each end so that it can be held and compressed.

Drum

The drum fits inside of the band and attaches to the planetary gearset element that is to be locked by the band. Its outer circumference is machined smoothly to interact with the friction surface of the band. By pulling the open ends of the band together, the rotation of the drum stops.

Anchor

The anchor firmly attaches one end of the brake band to the transmission case. A provision for adjusting the clearance between the band and the drum usually is provided on the anchor.

Servo

The servo uses hydraulic pressure to squeeze the band around the drum. The servo piston is acted on by hydraulic pressure from the valve body that is fed through an internal passage through the case. The servo piston has a seal around it to prevent leakage of hydraulic pressure and is spring loaded to allow quick release of the band. Some servos use hydraulic pressure on both sides of their pistons so that they use hydraulic pressure for both the release and the application of the band.

Operation

When the brake band is released, there is no hydraulic pressure applied to the servo and the drum is free to rotate within the band.

When the brake band is applied, hydraulic pressure is applied to the servo. The servo in turn, tightens the band around the drum. This action results in the drum being locked in a stationary position, causing an output change from the planetary gearset.

Overrunning (One-Way) Clutch

The overrunning clutch is used in certain automatic transmissions to lock a planetary gearset element to the transmission case so that it can act as a reactionary member. The operation of the overrunning clutch is the same as that of the one used in the torque converter, and it can be of the sprag or roller type. There is no control system necessary for this mechanism.

Learning Event 2:

DESCRIBE THE DRIVE TRAIN ARRANGEMENTS OF THE AUTOMATIC TRANSMISSION

Automatic transmissions are built with two, three, and four forward speeds and therefore use many variations of drive train arrangements. The following paragraphs describe the two most popular arrangements, the compound planetary drive train and the Simpson drive train.

Compound Planetary Drive Train

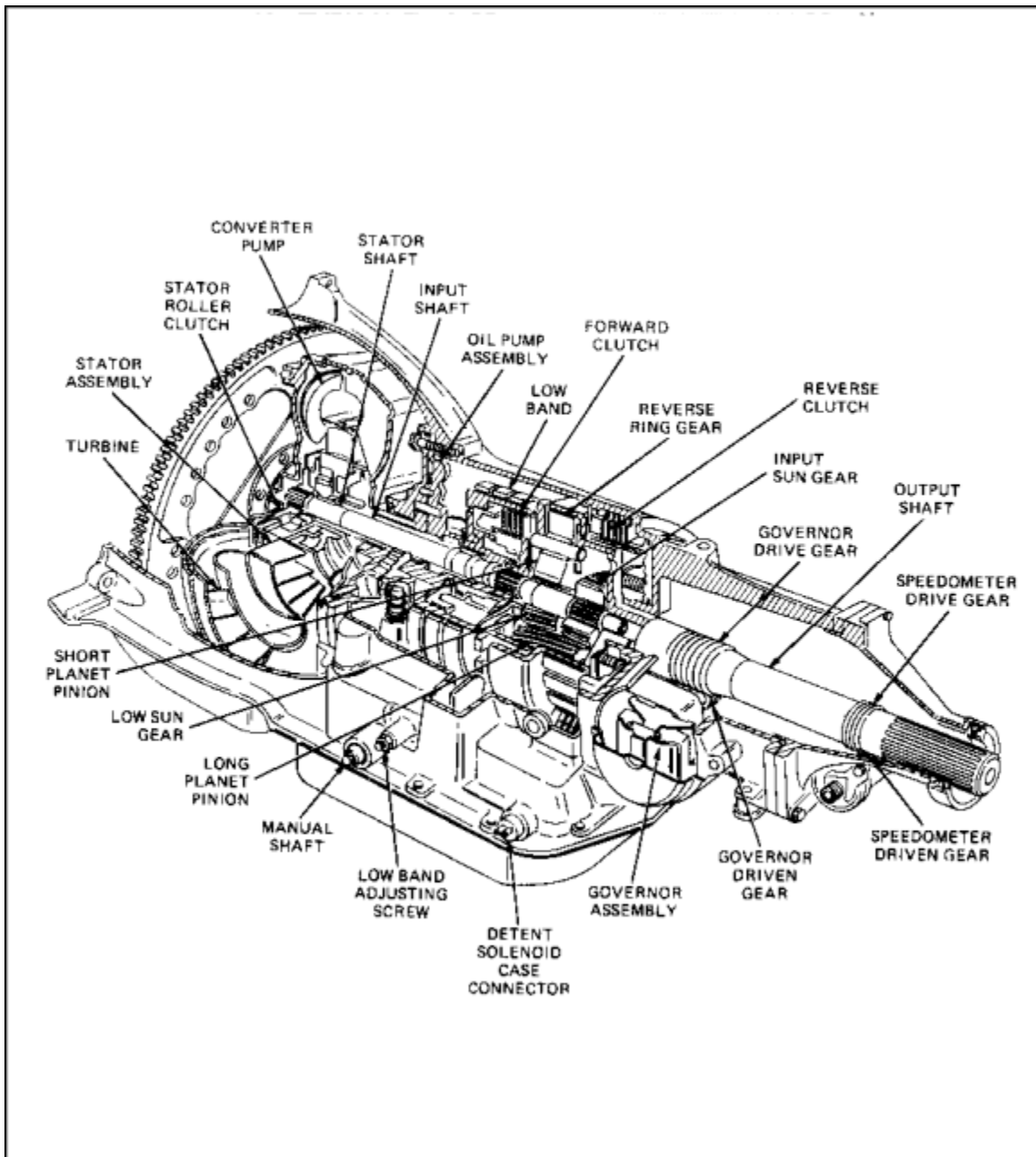

FIGURE 13. TYPICAL TWO-SPEED AUTOMATIC TRANSMISSION USING COMPOUND PLANETARY DRIVE TRAIN.

This arrangement combines two multiple-disk clutches and one brake band with a compound planetary gearset. The compound planetary gearset is really two gearsets that are integrated together through the use of long and short pinions. Because of the compactness of this unit, it has all but superseded earlier two-speed drive trains that use two separate planetary gearsets.

Operation

The compound planetary drive train provides two forward speeds, reverse, and neutral. Power flow in the different gear ranges are as follows:

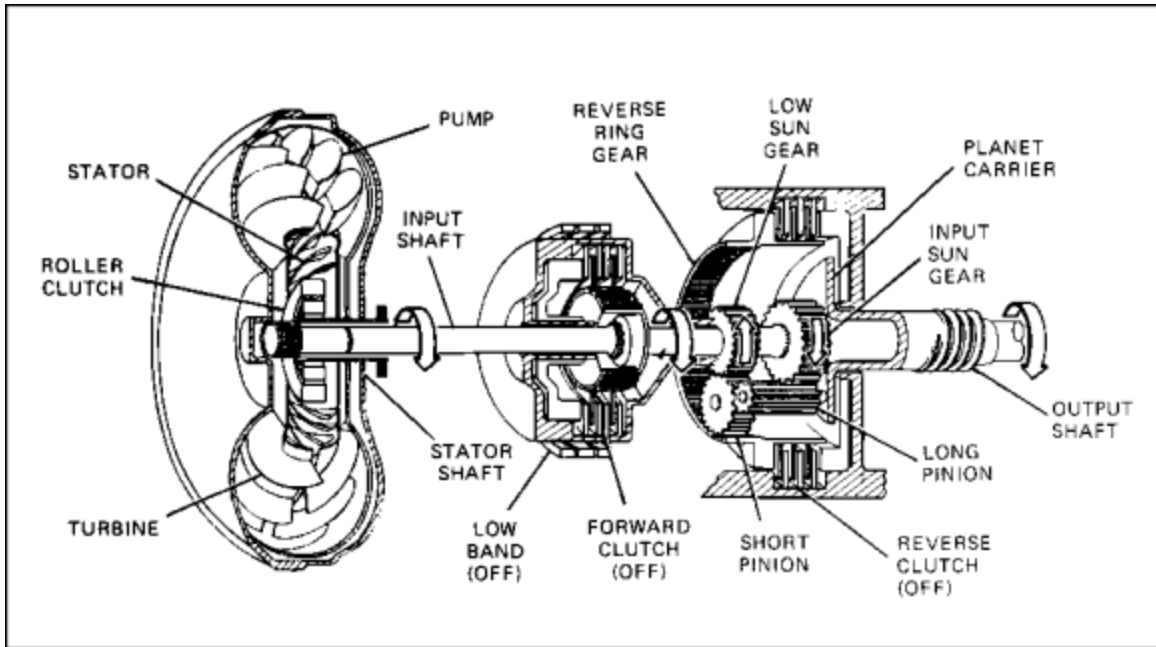

FIGURE 14. POWER FLOW - NEUTRAL.

Neutral

When the gearshift lever is placed in neutral, the clutch and brake bands are released. Because of this, there is no reactionary member in the planetary gearset to provide positive drive. Therefore, no torque is transmitted to the output shaft as all of the planetary gearset elements are free to spin around their axes.

Low

When the gearshift lever is placed in low, the direct and reverse clutches are released and the low brake band is applied, locking the low sun gear. Power flow through the drive train is as follows:

- From the input sun gear to the long planetary pinions.
- From the long planetary pinions to the short planetary pinions.

The locked sun gear then provides a reaction point so that the planetary pinions and carrier can walk around it, rotating the output shaft.

The result is a speed reduction ratio from the input shaft to the output shaft of about 1.8:1. The low-gear power flow also is used when the gearshift lever is in the drive position before the vehicle attains sufficient speed for the transmission to shift to direct drive.

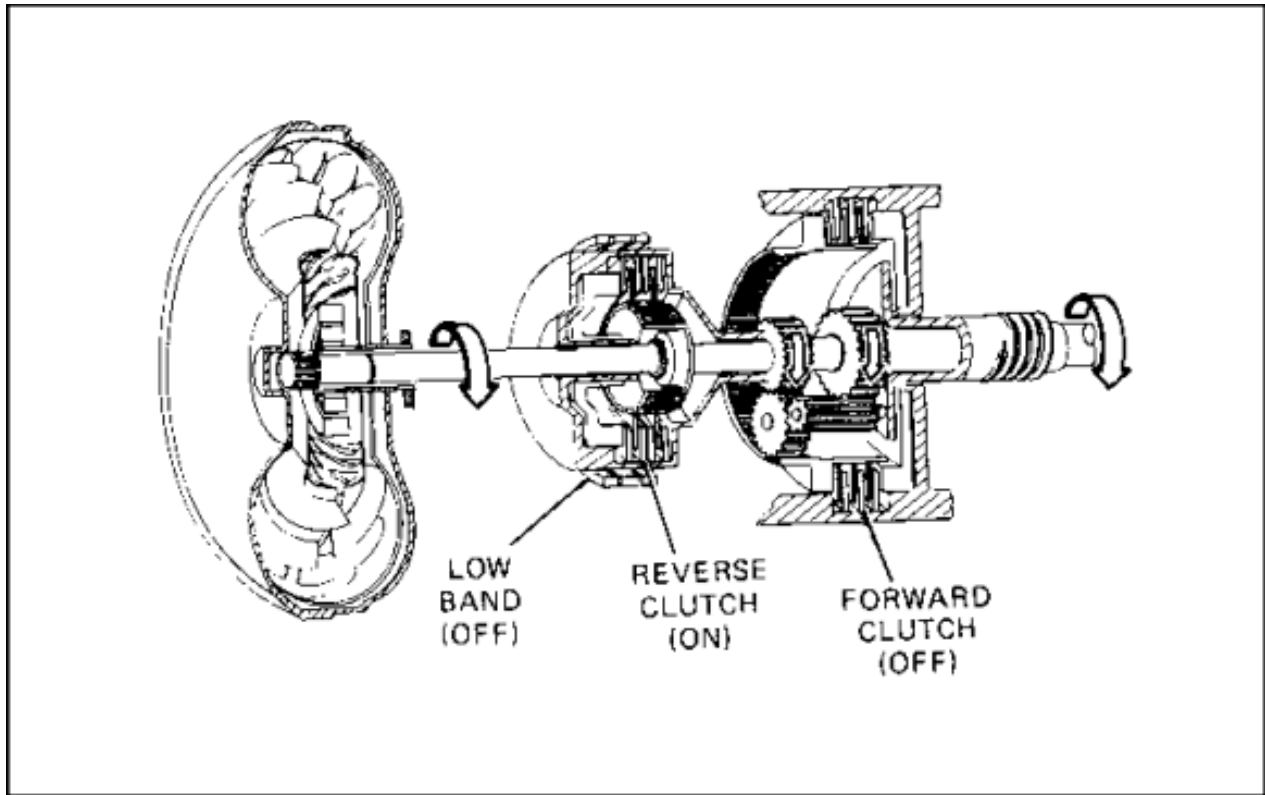

FIGURE 15. POWER FLOW - DIRECT DRIVE.

Direct Drive

When the gearshift lever is placed in drive, the transmission is in low gear until the vehicle reaches a speed sufficient to allow the transmission to automatically shift to direct drive. The shift to direct drive releases the low brake band and applies the direct clutch, locking the low sun gear to the input shaft. The reverse clutch remains released. Power flow through the drive train is as follows:

- From the input sun gear to the long planetary pinions.
- From the long planetary pinions to the short planetary pinions.

Because the input and low sun gears are both locked, the planetary pinions are locked and unable to rotate. This forces the planetary carrier and the attached output shaft to rotate at a 1:1 ratio with the input shaft.

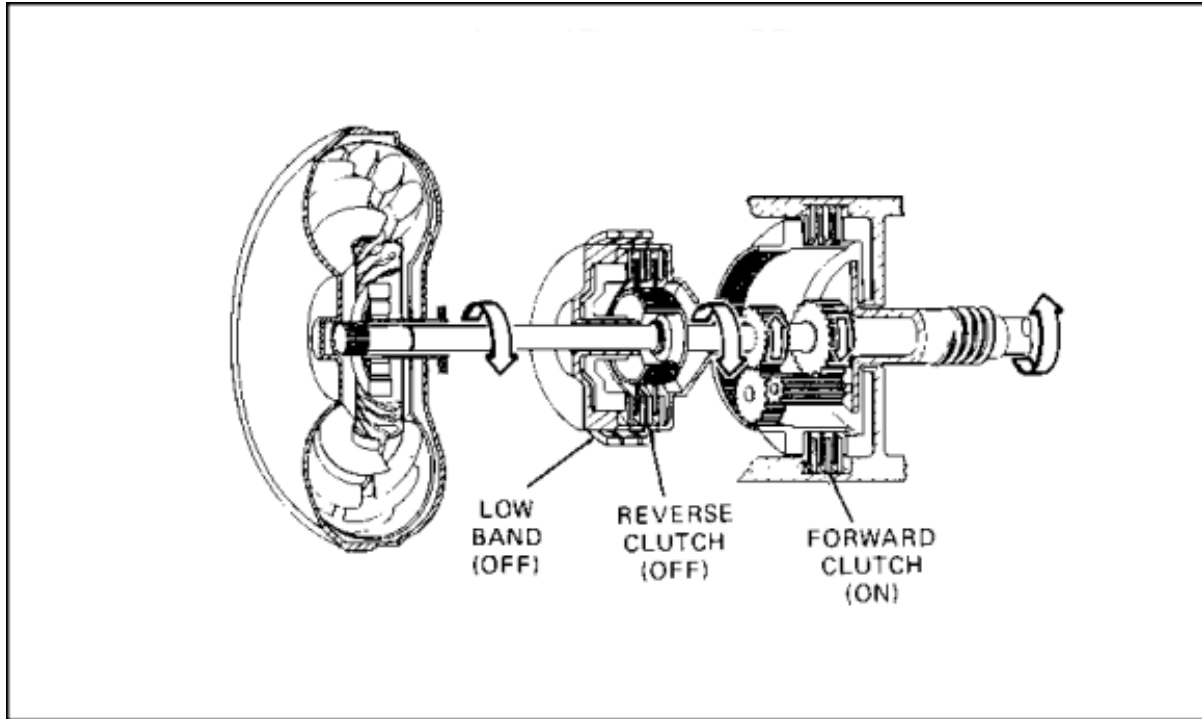

FIGURE 16. POWER FLOW - REVERSE.

Reverse

When the gearshift lever is placed in reverse, the low brake band and the direct clutch are released. The reverse clutch is applied, locking the internal gear of the planetary gearset. Power flow through the drive train is as follows:

- From the input sun gear to the long planetary pinions.
- From the long planetary pinions to the short planetary pinions.

The short planetary pinions walk around the inside of the locked internal gear, rotating the planetary carrier and the attached output shaft in the opposite direction of the input shaft. The speed reduction ratio of the input to the output shafts is approximately 1.8:1.

Simpson Drive Train

This arrangement combines two multiple-disk clutches, two brake bands, an overrunning clutch, and two planetary gearsets operating on a common sun gear. The Simpson drive train is the standard for virtually all three-speed automatic transmissions that are currently produced.

RANGE	GEAR	FRONT CLUTCH	REAR CLUTCH	KICKDOWN BAND	LOW-REVERSE BAND	OVERRUNNING CLUTCH
Reverse		on	off	off	on	nomovement
Neutral		off	off	off	off	nomovement
D-drive	first	off	on	off	off	holds
	second	off	on	on	off	overruns
	third	on	on	off	off	overruns
2-drive	second	off	on	on	off	overruns
	first	off	on	off	off	holds
1-low	first	off	on	off	on	holds

FIGURE 17. POWER FLOW.

Operation

The Simpson drive train provides three forward speeds, reverse, and neutral. Power flow is outlined in the above chart and the following text.

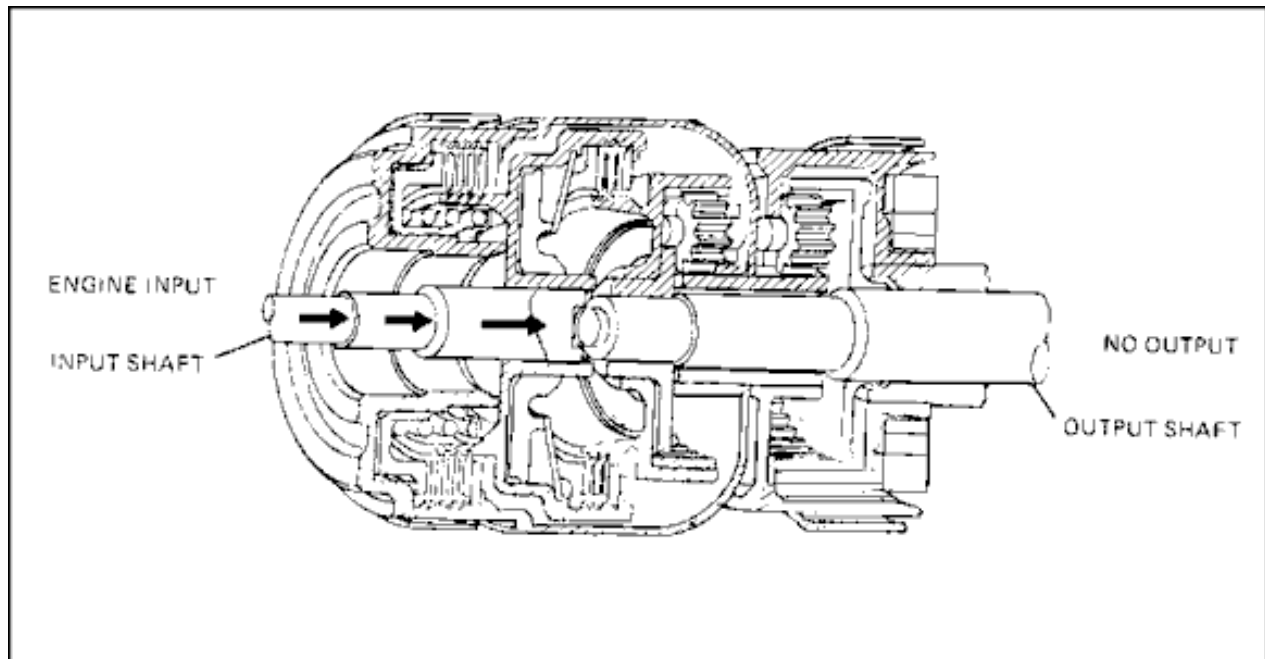

FIGURE 18. POWER FLOW - NEUTRAL.

Neutral

When the gearshift lever is placed in neutral, the clutch and brake bands are released. The input shaft rotates freely and no torque is transmitted to the output shaft.

Drive-Low

When the gearshift lever is placed in drive, the automatic transmission will be in low gear when the vehicle is in a speed range of zero to approximately 8 MPH. In drive-low, the rear clutch is engaged, locking the input shaft to the internal gear of the front planetary gearset. Power flow through the drive train is as follows:

- From the input shaft to the internal gear of the front planetary gearset.
- From the internal gear to the pinions of the front planetary gearset.

Because the front planetary carrier is locked to the output shaft, it cannot rotate backwards and therefore acts as a reactionary member. This causes the planetary pinions to drive the sun gear.

The sun gear, which is common to both planetary gearsets, then drives the rear planetary pinions.

The rear planetary carrier, which is locked to the transmission case by the overrunning clutch, serves as a reactionary member. The rear planetary pinions, therefore, drive the rear planetary internal gear and the attached output shaft at a speed reduction ratio of approximately 2.45:1.

Drive-Second

When the gearshift lever is in drive and the vehicle is between approximately 8 to 20 MPH, the transmission normally will be in second gear. In second gear, the rear clutch is applied, locking the input shaft to the internal gear of the front planetary gearset. The front brake band also is engaged, locking the sun gear stationary. Power flow through the drive train is as follows:

- From the input shaft to the internal gear of the front planetary gearset.
- From the internal gear to the pinions of the front planetary gearset.

Because the sun gear is locked, it acts as a reactionary member. This causes the planetary pinions to walk around it and rotate the front planetary carrier, which drives the attached output shaft.

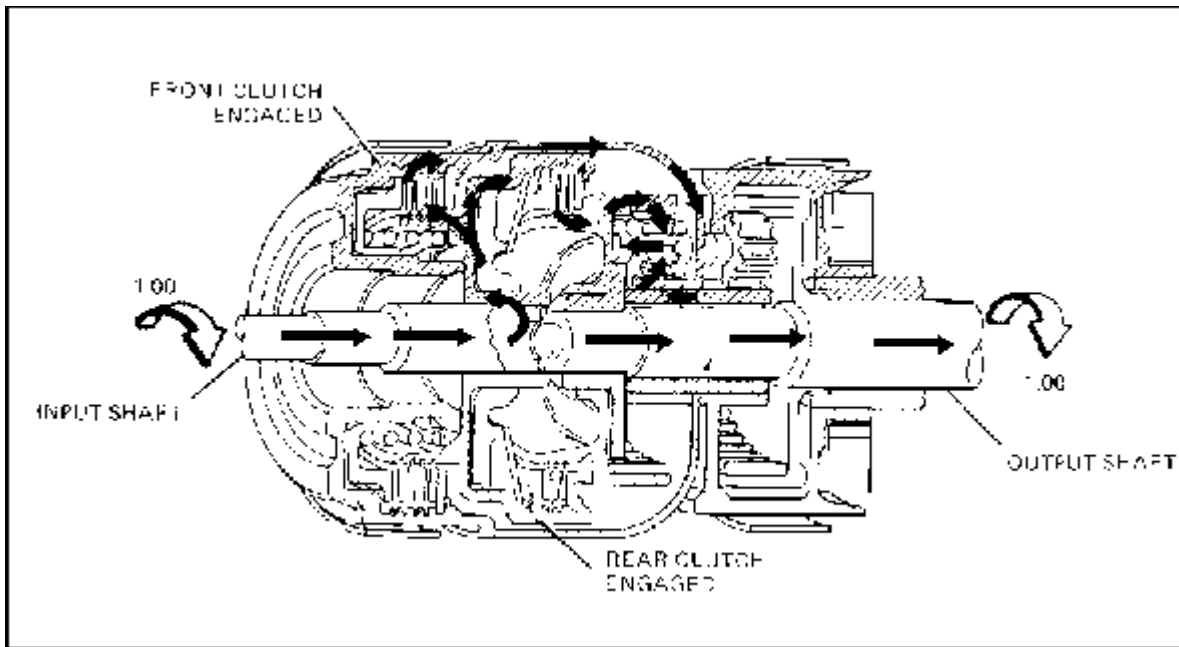

FIGURE 19. POWER FLOW - D (DRIVE) POSITION - DIRECT.

Direct Drive

When the gearshift lever is in drive and vehicle speed is above approximately 25 MPH, the automatic transmission normally is in direct drive. In direct drive, both the front and rear clutches are applied, which ultimately results in the locking of the internal gear to the internal gear in the front planetary gearset. This results in the planetary gears being locked and the whole planetary gearset and the attached output shaft rotating at a 1:1 speed ratio with the input shaft.

Low

When the gearshift lever is placed low, the power flow through the drive train is identical to that of drive-low described above. The only difference is the use of the rear brake band rather than the overrunning clutch to lock the carrier of the rear planetary gearset. Because the rear brake band prevents the element from rotating in either direction, the drive train is able to provide engine braking during vehicle deceleration with the transmission in low. This contrasts with drive-low, which allows the vehicle to freewheel during deceleration due to the one-way locking of the overrunning clutch.

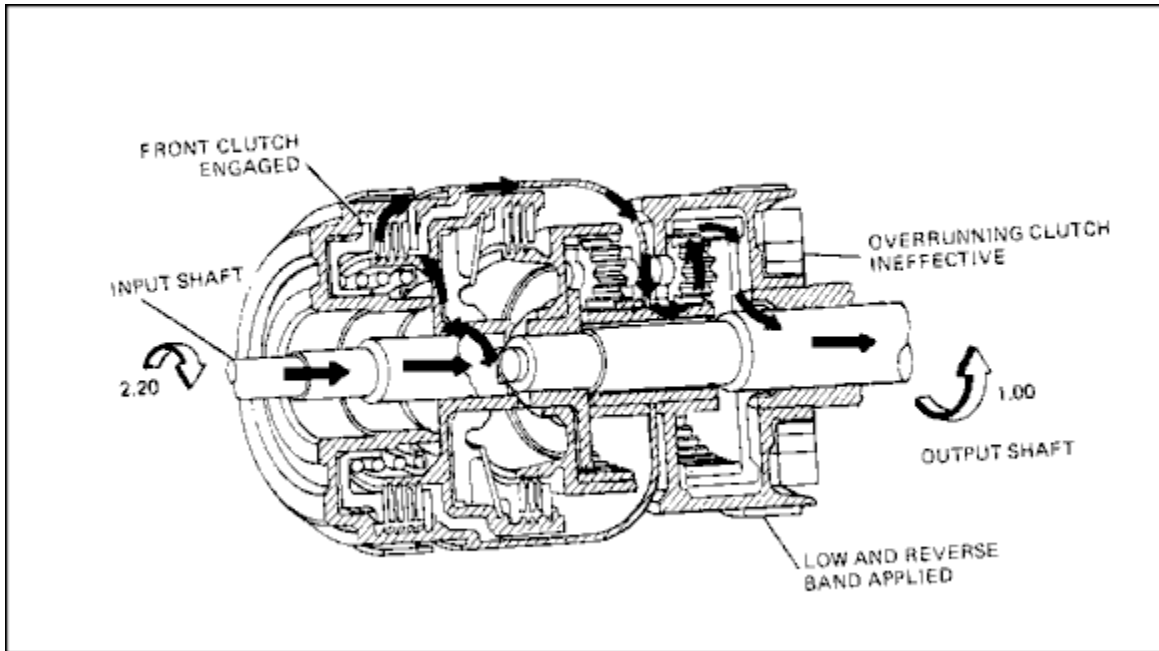

FIGURE 20. POWER FLOW - REVERSE.

Reverse

When the gearshift lever is in reverse, the front clutch is applied, locking the sun gear to the input shaft. The rear brake band also is applied, holding the carrier of the rear planetary gearset stationary. Power flow through the drive train is as follows:

- From the input shaft to the sun gear.
- From the sun gear to the rear planetary pinions.

Because the rear planetary carrier is held stationary, it acts as a reactionary member. The rear planetary pinions, therefore, drive the internal gear of the rear planetary gearset and the attached output shaft in reverse rotation to the input shaft at a speed reduction ratio of approximately 2.2:1.

Learning Event 3:

DESCRIBE THE HYDRAULIC SYSTEM OF THE AUTOMATIC TRANSMISSION

PURPOSE

Hydraulic pressure from the hydraulic slave circuits actuate the planetary holding devices (clutches and brake bands).

The hydraulic system controls the shifting pattern of the transmission. This is done by switching hydraulic pressure to programmed combinations of the planetary holding devices based on vehicle speed and engine load indicators.

The hydraulic system circulates oil through a remote cooler to remove excess heat that is generated in the transmission and torque converter.

The hydraulic system provides a constant, fresh supply of oil to all critical wearing surfaces of the transmission.

SUPPLY SYSTEM

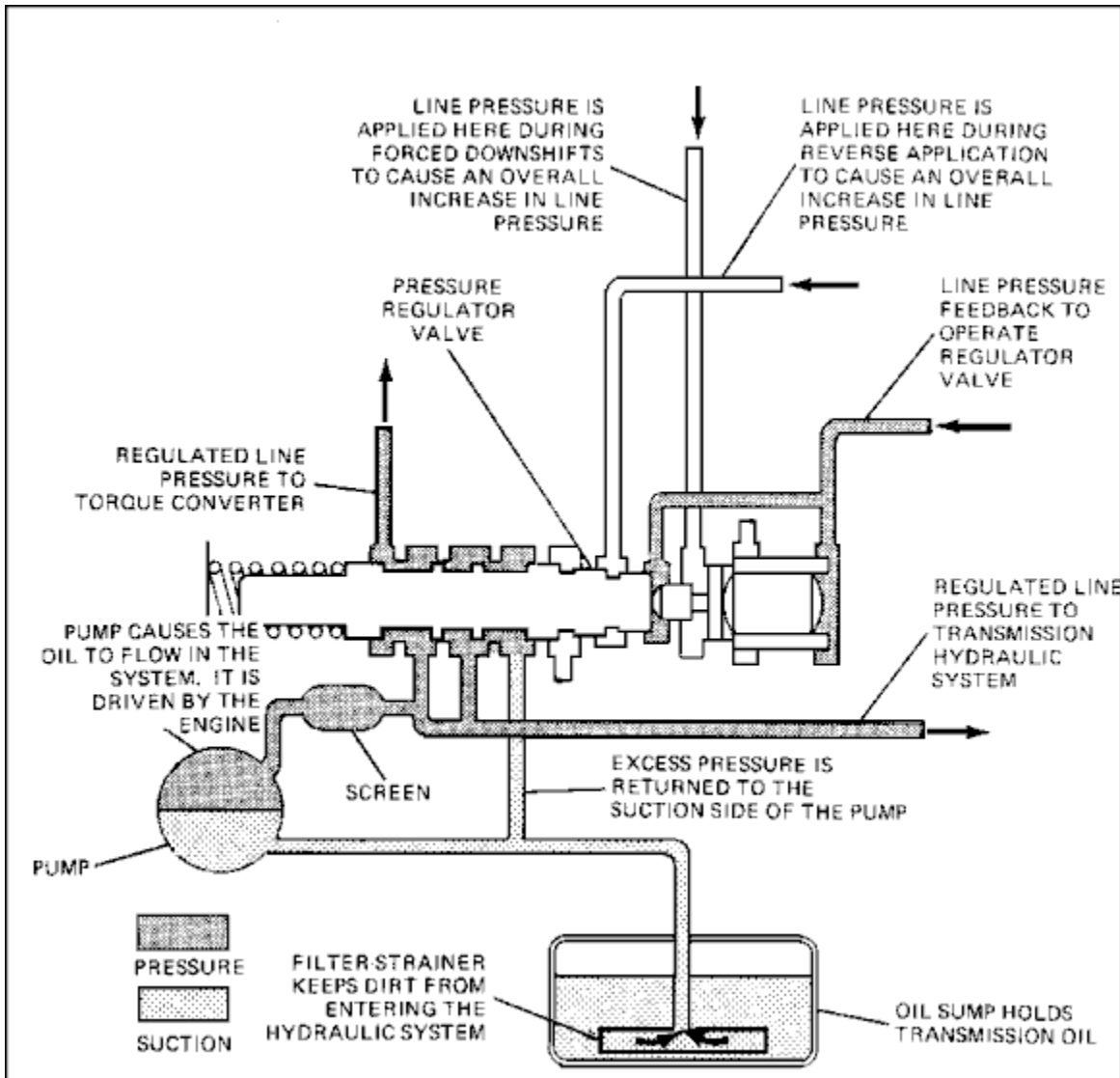

FIGURE 21. TYPICAL HYDRAULIC SUPPLY SYSTEM.

The supply system provides a clean, pressure-regulated supply of oil for the hydraulic system of the automatic transmission. Early automatic transmissions used a combination of an engine-driven pump that worked in conjunction with an output shaft-driven pump. This configuration no longer is used and, therefore, will not be covered. The operation and construction of a typical system is described below.

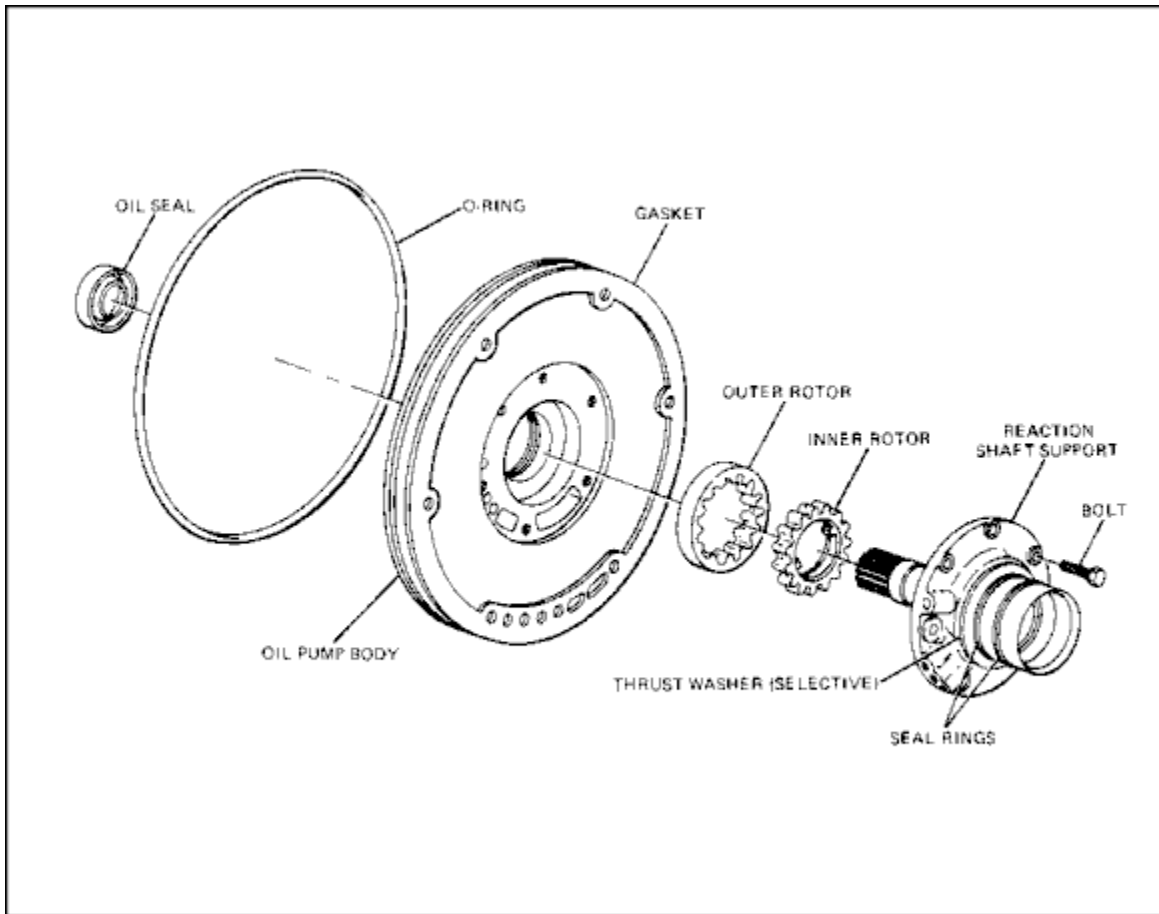

FIGURE 22. TYPICAL TRANSMISSION HYDRAULIC PUMP.

Hydraulic Pump

The typical hydraulic pump is usually a standard-type internal-external rotor-type pump or an internal-external gear-type pump. It usually is located in the front of the transmission case and is keyed to the torque converter hub so that it is driven by the engine.

Oil Sump and Filter

The oil sump usually is in the form of a sheet metal pan that attaches to the bottom of the transmission case. The pump draws oil from the sump through a strainer. The strainer usually is made of paper or metal.

Regulator Valve

The regulator valve controls the pressure of the hydraulic pump so that the hydraulic system of the transmission receives a constant working pressure. The pressure supply received by the hydraulic system is called line pressure.

Pump pressure is fed to the hydraulic system through the spool valve. The spool is held to the right by a calibrated spring. In this position, the spool closes the port that allows pump pressure to be fed back to the pump suction line.

After the pump pressure leaves the spool valve, a portion of it is fed back to the end of the spool valve, opposite to the spring. This pump pressure signal attempts to move the spool against spring pressure.

As pump pressure overcomes the spring pressure, the spool is pushed to the left, uncovering the pump suction feedback port. Pump pressure then is bled off through this port causing a line pressure drop.

The line pressure drop allows the spring to close the bleed port, which, in turn allows pump pressure to build again. From then on the regulation of line pressure is a constant cycle between pump and spring pressure operating the spool valve.

The valve described above is a balance-type spool valve. Balance-type spool valves are very common in the transmission's hydraulic system.

Modulation of the Regulator Valve

After the pump pressure passes through the regulator valve, it becomes regulated line pressure. In operation, however, automatic transmissions need more than one set line pressure. To accomplish this, additional signals are fed to the regulator to modulate the line pressure for specific purposes. The following considerations are the most common in the modulation of line pressure:

- Under normal conditions, the regulator valve functions in an unmodulated mode as described in the previous paragraph. Normal line pressure is sufficient to operate the transmission and still maintain a smooth shifting quality.

- During periods of heavy acceleration, additional line pressure is required to hold the clutches and brake bands tight enough to transmit the increased engine torque. This is particularly important during the initial application of the elements during shift changes to minimize slippage during engagement, which would cause burning and premature wear of friction facings.
- Operation in reverse places additional torque requirements on the clutch or brake band that holds the element of the planetary gearset. For this reason, the line pressure is increased at least twofold during operation in reverse.
- Any condition that causes a drop below line pressure will cause the regulator valve to temporarily cut off the oil supply to the torque converter. A common occurrence of this condition is the shifting to reverse, which temporarily increases the requirements placed on the pump while the engine is idling and the pump is turning slowly.

Modulation of the line pressure is a fairly simple matter. Pressure signals are fed back into the regulator valve to assist the spring. The result is that the line pressure must increase to overcome the higher pressure before the suction feedback port is uncovered. The feedback signals come from the manual valve and the throttle modulation system.

CONVERTER FEED CIRCUIT

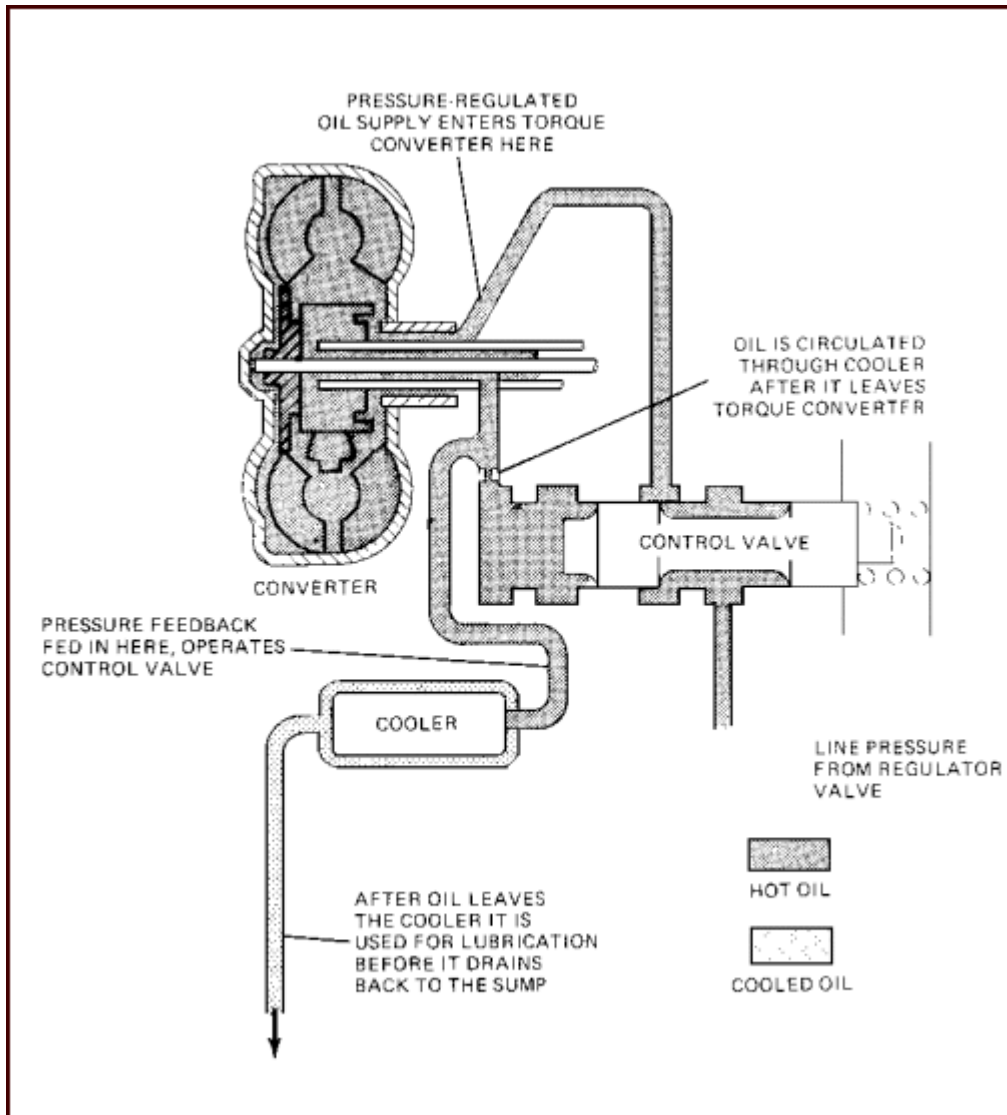

FIGURE 23. TYPICAL TORQUE CONVERTER FEED CIRCUIT.

Torque converter supply, cooling, and lubrication tasks are all handled by the converter feed circuit of the hydraulic system.

This integration is a logical one for the following reasons:

- All phases of this circuit will function within approximately the same operating pressure range.

- The majority of the heat generated within the transmission originates in the torque converter. It is therefore logical that the oil, after it circulates through the torque converter, should pass directly to the cooler. This arrangement effectively isolates the transmission from this major heat source.
- A major reason for lubrication within the transmission is to cool the localized areas where heat is generated between moving parts. For this reason, transmission lubrication is handled by the oil after it is passed through the cooler.

Oil Supply

The supply of oil for the converter feed circuit passes through the regulator valve. The regulator valve will cut off this oil supply if line pressure drops below an operating minimum. Under normal circumstances, however, the oil pressure cutoff will last no more than a few seconds and will not affect transmission operation. During periods of engine shutdown, the regulator valve also prevents the torque converter from draining back to the oil sump. This condition otherwise would require the pump to refill the converter at each engine restart, creating an unacceptable delay in operation.

Regulation of Circuit Oil Pressure

The regulator valve supplies the converter feed circuit at regulated line pressure. The converter feed circuit, however, requires a constant pressure that is independent of transmission operating modes and generally lower than line pressure. The converter control valve controls the pressure for the converter feed circuit. The converter control valve is a balance-type spool valve whose operating principles are much like that of the regulator valve. When operating pressure is low, the calibrated spring pushes the spool to the left, opening the delivery port. As pressure reaches the desired level, the spool is forced to the right, blocking the delivery port. A metered orifice is usually provided between the torque converter and the cooler to control the volume of oil flow through the system.

Oil Flow Through the Torque Converter

Oil flow through the converter, in most cases, is as follows:

- Oil passes from the converter control valve to the torque converter through internally drilled passages in the transmission case.

- The oil enters the torque converter through a clearance between the outside of the stator support and the inside of the converter hub.
- After the oil circulates within the converter, it exists through a clearance between the input shaft and the inside of the stator support shaft.
- The oil then passes through an internally drilled passage to the oil cooler outlet.

Cooler

The cooler is a heat exchange that is located remotely from the transmission. The following are the most popular configurations:

- The most popular transmission cooler for use in light vehicles is integral with the engine radiator. The cooler is basically a pipe that extends for the entire length of the inside of the outlet tank of the radiator. As the oil passes through the cooler, a portion of its latent heat is transferred to the engine coolant. The oil then returns to the transmission. (It should be noted that there is no mixing or physical contact between the engine coolant and the transmission oil.)
- In heavy-duty use, a separate oil-to-air type cooler is preferred. This is because in severe use, enough heat can be generated by the transmission to actually cause the engine to overheat if transmission heat is transferred directly to the engine coolant. The oil-to-air type heat exchanger is built much the same as an automotive radiator. It consists of a continuous tubing arranged in rows. The rows of tubing pass through a series of fins. As the oil passes through the tubing, its latent heat is transferred to the air via conduction through the fins. This type of cooler usually is located in front of the engine radiator where it is subjected to airflow. This condition is important for its efficient operation.

Lubrication

After the oil is passed through the oil cooler, it is piped through internal passages in the transmission case to the rear section of the transmission where it provides lubrication for components such as the planetary gearsets and output shaft bearings. The oil then drains back to the sump. (At this time, it should be noted that the oil sump also dissipates heat from the transmission oil and is considered to be a source of transmission cooling.)

RANGE CONTROL SYSTEM

The range control system provides automatic or operator-controlled shifting of the transmission. Shifting of the transmission is controlled by the following two indicators:

Manual Selection

The position of the gearshift lever selected by the operator chooses the desired shifting program. The selections available to the operator of a typical two-speed unit are:

- Neutral (N). In neutral (N), the engine freewheels, providing no driving force to the vehicle.
- Drive (D). In drive (D), the transmission provides automatic shifting through the low- to high-gear ranges.
- Drive-Low (L). In drive-low (L), the transmission is locked in the low range and no automatic shifting occurs.
- Reverse (R). Reverse (R) reverses the direction of engine torque to drive wheels, and the vehicle is driven backwards.
- Park (P). Park (P) is the same as neutral except that the drive wheels are locked by a positive latching device within the transmission.

The three-speed transmission has all of the above selections plus drive second. This position allows for an automatic shift from first to second gear, but blocks an automatic shift from second to third gear.

Vehicle Speed Versus Engine Loading

Shifting of the automatic transmission is controlled by two pressure signals that are indicators of speed and engine loading. These signals work against each other to produce a shifting sequence.

The center of all shift control is the valve body. This unit, which can be thought of as a hydraulic computer, receives information from the indicators described above. Based on this information the valve body switches line pressure to the proper planetary holding elements to produce the required gear range. As the information changes the valve body changes its line pressure outputs accordingly. For the sake of simplicity, a two-speed transmission will be used to explain the operation of all of the typical components. A hypothetical automatic transmission hydraulic system will be constructed in this paragraph? It must be stressed that this hypothetical system by no means contains all of the devices necessary in a real transmission. It is useful for the sake of learning, because it clearly illustrates how the decision and the action of shifting is initiated.

Manual Valve

The manual valve is the device that selects the desired shift program through the position of the gearshift lever. A manual valve is basically a multiport spool valve that switches line pressure to selected passages as it is moved through its operating positions.

Governor

The governor modulates line pressure to produce a signal that is an indication of vehicle speed. This signal is used by the valve body to formulate gear-range selections for the transmission. The governor uses a spool valve that is operated by centrifugally operated weights. The weights are rotated by the output shaft of the transmission because it is solidly linked to the drive wheels and therefore consistently provides a true indication of vehicle speed. As the weights rotate, they are acted on by centrifugal force which tends to pull them outward from the axis of rotation. The weights are pulled inward by specially calibrated springs that allow the weights to move from a fully retracted to a fully extended position within a desired output shaft speed range. The spool valve is in a position where all line pressure is blocked when the governor weights are fully retracted. As the weights move outward, the spool valve gradually opens the line pressure port to the governor pressure port. The result is an approximate linear speed and governor pressure increase.

Shift Valve

The shift valve is a simple balance-type spool valve that selects between low and high gear when the manual valve is in the drive (D) position. Governor pressure acts on the spool valve in one direction, trying to push the spool towards the high-gear position. At the same time, spring pressure modulated by the position of the accelerator pedal tries to push the spool toward the low-gear position. The decision of the shift valve is dependent on which pressure is greater, governor or throttle. The shift valve also contains a device known as a throttle plug. At full throttle, the throttle plug makes physical contact with the shift valve spool, forcing it into the low-gear position. This is how a forced downshift (passing gear) is initiated.

Operation

The following subparagraphs describe the operation of a hypothetical hydraulic system for a two-speed automatic transmission in all of its modes of operation. A reverse band rather than a reverse clutch is used in this hypothetical transmission.

- When the shift lever is placed in neutral (N), line pressure is blocked at the manual valve and none of the frictional elements are applied.
- When the shift lever is placed in drive-low (L), the manual valve delivers line pressure directly to the low band. The compound planetary gear train then is in low gear.
- When the gearshift lever is placed in reverse (R), the manual valve delivers line pressure directly to the reverse band. The compound planetary gear train then is in low gear.
- When the gearshift lever is placed in drive (D), the manual valve delivers line pressure directly to the low band and to the governor. Because the vehicle is not moving, the governor does not supply pressure to the shift valve and the compound planetary gear train remains in low gear.

- As the vehicle begins to move with the gearshift lever in drive, the transmission is in low gear, providing the engine with the necessary mechanical advantage to accelerate the vehicle to speed. As the vehicle speed increases, the governor pressure rises proportionately. When vehicle speed reaches a point where the governor pressure on one side of the shift valve spool can overcome the throttle spring pressure on the other side of the shift valve spool, the spool moves to the direct or high-gear position. As the valve spool moves, the shift valve begins to deliver line pressure to apply the direct clutch and release the low band. The low band, so that it can be released while it is still under apply pressure, uses a double-acting servo. The double-acting servo can be released by applying pressure under the piston. The diameters of the piston and the bore of the double-acting servo are stepped so that the pressure under the piston will act on a greater surface area and therefore overcome apply pressure. The application of the direct clutch and the release of the low band place the compound planetary gear train in high gear or direct drive. The pressure exerted by the throttle spring against the shift valve spool increases proportionately as the accelerator is depressed. This in turn will proportionately raise the vehicle speed at which automatic upshifts occur.
- If a situation arises when quick acceleration is needed, the operator can initiate a forced downshift by pushing the accelerator to the floor. This action causes the throttle plug to contact the shift valve spool, forcing it into the low-gear position. This action cuts off line pressure to the direct clutch and the release side of the low-band servo, causing the direct clutch to release as the low band applies. This places the compound planetary gear train in low gear.

Auxiliary Devices

The hypothetical hydraulic system mentioned above is a good learning tool; however, to actually function, many more devices are necessary. The following devices are necessary in addition to the basic operation of the hydraulic system:

Devices called accumulators are connected into the pressure supply lines of selected planetary gearset holding elements. An accumulator is a spring-loaded piston that causes line pressure to build gradually when the element is applied. This gives a cushioning effect to its application, resulting in smoother shifting of the transmission.

Lesson 4/Learning Event 3

Valves are installed to prevent the transmission from being shifted into reverse during forward movement and to prevent a forced downshift above a predetermined speed.

A modulator is used in some automatic transmissions in place of throttle linkage. The modulator is a diaphragm device that uses engine manifold vacuum to indicate engine load to the shift valve

PRACTICE EXERCISE

1. The automatic transmission is coupled to the engine through
 - a. an overrunning clutch.
 - b. a torque converter.
 - c. a planetary gearset.

2. The multiple-disk clutch is used to
 - a. engage the automatic transmission.
 - b. lock planetary gearset elements.
 - c. cushion the torque converter.

3. The automatic transmission shifts gears by locking and releasing
 - a. planetary gearsets.
 - b. multiple-disk clutches.
 - c. brake bands.

4. The shifting pattern of the transmission is controlled by the
 - a. shift lever.
 - b. regulator valve.
 - c. hydraulic system.

5. The center of all shift control is the
 - a. valve body.
 - b. modulator valve.
 - c. shift tower.

ANSWERS TO PRACTICE EXERCISE

1. b (page 63)
2. b (page 64)
3. a (page 64)
4. c (page 79)
5. a (page 89)

LESSON 5
FUNDAMENTALS OF TRANSFER CASES

TASK

Describe the fundamentals of transfer cases.

CONDITIONS

Given information on the construction, lubrication, and operation of transfer cases.

STANDARDS

Answer 70 percent of the multiple-choice items covering fundamentals of transfer cases.

REFERENCES

TM 9-8000

Learning Event 1:

DESCRIBE THE CONSTRUCTION AND OPERATION OF TRANSFER CASES

In previous lessons, we discussed how transmissions could provide various gear ratios so that the engine could develop enough power for starting a vehicle, running at high speeds, and pulling heavy loads. We also mentioned that military vehicles had to be able to operate in mud, snow, sand, and other unusual terrains. To do this, driving power has to be available at the front wheels as well as the rear wheels so the vehicle will not get stuck. Therefore, tactical military wheeled vehicles include a second gearbox called the transfer case. Its purpose is to take the output power from the transmission and divide it so that it will drive the rear wheels at all times and drive the front wheels when needed.

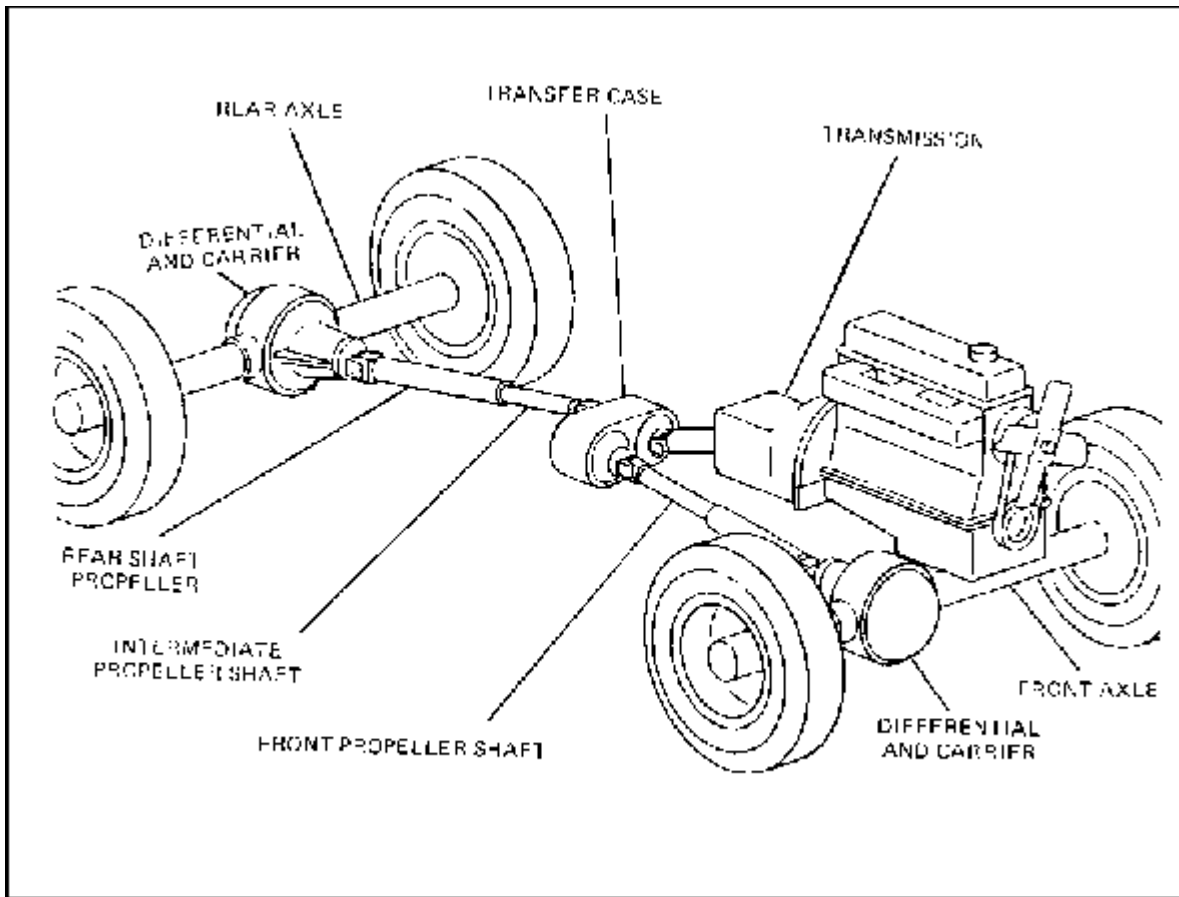

FIGURE 25. TYPICAL DRIVELINE ARRANGEMENT WITH TRANSFER ASSEMBLY.

The transfer case can be mounted in several ways in a vehicle. It can be a separate component mounted to the rear of the transmission and driven by a propeller shaft connecting it to the output of the transmission. It can also be a part of the transmission and driven by a gear on the output shaft of the transmission. The transfer case performs one or more of the following functions:

- It transfers the transmission power to a point low enough so that a propeller shaft can be mounted under the engine and power the front axle.
- It provides an output to power one or more rear axles.
- It provides a high and low gear ratio for vehicles that do not have the necessary gear reductions in the transmission.

- It provides arrangements for engaging and disengaging front wheel drive and high and low ranges when applicable.

Because of its many functions, the shape, mounting, construction, and appearance of transfers for various vehicles will differ. In the following paragraphs, we will discuss the wheeled vehicle transfer cases.

The transfer case used with the M151A1, 1/4-ton vehicle is also mounted directly on the transmission. This transfer does not provide a separate gear reduction and has only a direct drive. It does have a shift lever for engaging and disengaging the front-wheel drive.

The transfer case of the M561, 1 1/4-ton truck is mounted at the output end of the transmission. It transfers power from the transmission to the propeller shafts and differentials. Selections are high- and low-operating ranges, neutral to disengage the case, and two- or six-wheel drive. Two-wheel drive disengages the front and rear axles, leaving only the center wheels to drive the vehicle.

The 3/4-ton and 1 1/4-ton trucks use the same type of transfers. They are mounted behind the transmission and connected to the output of transmission. They contain a high and low range. Engaging and disengaging of front-wheel drive and range selections are done manually with shift levers.

The 2 1/2-ton and 5-ton truck transfers are similar. They are mounted behind the transmission and powered by a propeller shaft. All have a high and low range which is selected with a manual lever. On some vehicles, the front-wheel drive engages automatically anytime the rear wheels start turning faster than the front wheels. This is done with a sprag unit that is similar to a bicycle coaster brake. On other models, the front-wheel drive is engaged and disengaged with a manual shift.

For our discussion in this lesson, we will refer to the transfer cases used on 2 1/2-ton trucks primarily. Most transfers work about the same. However, more unit level maintenance is required on 2 1/2-ton transfers than most other models.

CONSTRUCTION OF A TYPICAL TRANSFER

To understand how a transfer case works, it is best to first become familiar with the location of the internal parts.

The typical transfer assembly has one input shaft and three output shafts. Other transfers may have one input shaft and two output shafts: one shaft for the front axle and one for the rear axle or axles. Their operations will be much the same.

We will discuss the components as they are listed.

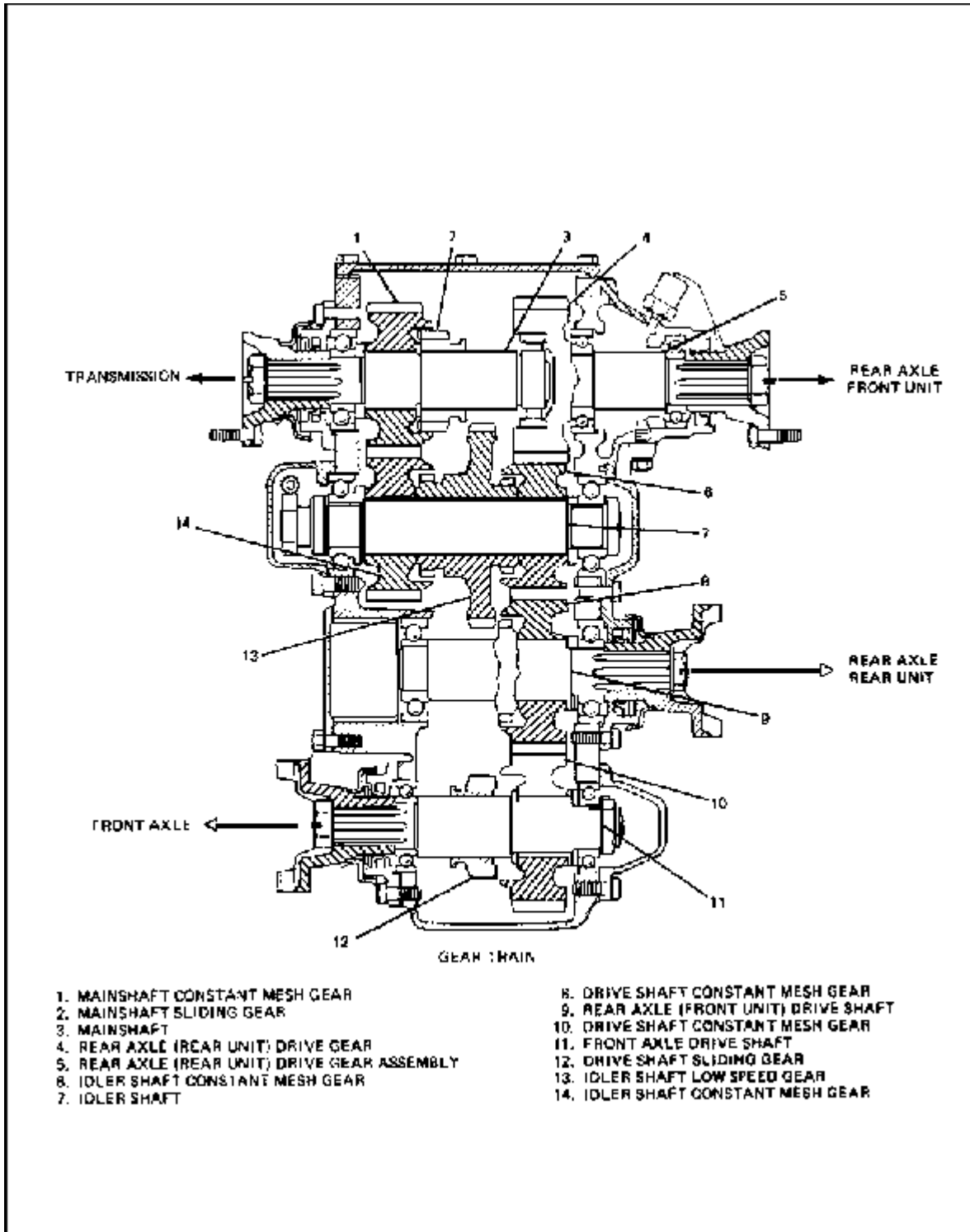

FIGURE 26. TYPICAL CONVENTIONAL TRANSFER ASSEMBLY FOR 6X6 VEHICLES.

Lesson 5/Learning Event 1

At the top of the illustration, look at gear (1). It is mounted on the main input shaft (3) but is free to rotate without turning the shaft. It has external teeth on the outside that are in constant mesh with gear (14). It also has internal gear teeth on the inside. Gear (2) is also mounted on the main input shaft (3). However, notice that this gear is splined to the shaft and must turn anytime the input power shaft turns. It can slide back and forth on the shaft between gears (1) and (4). This gear has external teeth and acts as a dog clutch between gear (1) and shaft (3).

Gear (4), the rear axle (rear unit) drive gear, is fastened to and turns item (5), the rear axle (rear unit) drive shaft assembly. Gear (4) is in mesh with gear (6), the idler shaft constant-mesh gear.

Gear (6) has both external and internal teeth. It is mounted on, and is free to turn on, item (7), the idler shaft. The idler shaft constant-mesh gear is in mesh with gear (8), the drive shaft constant-mesh gear.

The drive shaft constant-mesh gear has external and internal teeth. It is mounted on item (9), the rear axle (front unit) drive shaft. An external tooth gear, fastened to item (9), is in mesh with the internal teeth of the drive shaft constant-mesh gear (8). This gear turns item (9), the rear axle (front unit) drive shaft.

Gear (8) is in mesh with gear (10), the drive shaft constant-mesh gear. This gear has external and internal teeth and is mounted on, and free to turn on, item (11), the front axle drive shaft.

Gear (12), the drive shaft sliding gear, has external teeth and internal splines and can slide on the splines of the front axle drive shaft. When the external teeth of gear (12) are in mesh with the internal teeth of the drive shaft constant-mesh gear (10), the front axle drive shaft is engaged and will turn at the same speed as gear (10).

Gear (13), the idler shaft low-speed gear, is mounted on the idler shaft. One end of gear (13) is in mesh or engaged with gear (6), the idler shaft constant-mesh gear. The other end is in mesh or engaged with item (14), another idler shaft constant-mesh gear. This locks gears (6), (13), and (14) together so they turn as a unit. The idler shaft constant-mesh gear (14) is in mesh with the main shaft constant-mesh gear (1).

OPERATION

Now that you have seen how the parts of a transfer fit together, we will take a look at what goes on when the transfer is in operation. When the transfer is operating in high range, with the front-wheel drive engaged, all wheels are pulling.

Power comes into the transfer from the transmission on the main shaft (3). When the main shaft turns, the main shaft sliding gear (2) turns because it is splined to the main shaft. In high range, the main shaft sliding gear is in mesh with the internal teeth of gear (1), the main shaft constant-mesh gear. This causes gear (1) to turn.

The external teeth of gear (1) are in mesh with the external teeth of gear (14), the idler shaft constant-mesh gear. When gear (1) turns, it drives gear (14).

One end of gear (13), the idler shaft low-speed gear, is in mesh with gear (14). The other end is in mesh with gear (6), the other idler shaft constant-mesh gear. This means that when gear (14) turns, all gears on the idler shaft turn.

Gear (6) is in mesh with gear (4). When gear (6) turns, it drives gear (4); gear (4) turns shaft (5) which sends power to the rear axle rear unit.

Gear (6) is also in mesh with and drives gear (8). The internal teeth of gear (8) are in mesh with the gear fastened to shaft (9). When gear (8) is turned, power is sent to the rear axle front unit.

Gear (8) is also in mesh with and turns gear (10). When the front-wheel drive is engaged, gear (10) is in mesh with and drives gear (12), the drive shaft sliding gear. Gear (12) is splined to shaft (11), the front-axle drive shaft. When gear (12) is turned, power is sent through shaft (11) to the front axle. The driver, by means of a shift lever and linkage, can slide gear (12) away from gear (10). When gear (12) is not in mesh with gear (10), no power is being sent to the front axle.

When more torque is needed to move the vehicle, the driver can shift the transfer to low range. The shifting linkage on some vehicles is made so that the vehicle must be in front-wheel drive before shifting to low range. This prevents the driver from sending full torque to the rear wheels only, which might cause damage.

Lesson 5/Learning Event 1

When the transfer is shifted to low range, the mainshaft sliding gear (2) is disengaged from the constant-mesh gear (1). It is then engaged with the idler shaft low-speed gear (13). Gear (2) is the driving gear and is smaller than driven gear (13). This gives less speed and more torque or a gear reduction. From here on, the power flow is the same as in high range. The transfer is in neutral, while gear (2) is not in mesh with either gear 1 or gear

Learning Event 2:**DESCRIBE THE CONSTRUCTION AND OPERATION OF SPRAG UNITS**

Some transfers contain an overrunning sprag unit (or units) on the front output shaft. The operation of these units is much like that of an overrunning clutch in the starting motor.

On these units, the transfer is made to drive the front axle a little slower than the rear axle(s). During normal operation on good roads, when both front and rear wheels turn at the same speed, only the rear wheels drive the vehicle. However, if the rear wheels start to slip, they turn faster than the front wheels. If this happens, the sprag unit automatically engages so that the front wheels also drive the vehicle. The sprag unit simply provides an automatic means of engaging the front-wheel drive whenever the back wheels start to slip. There are three types of sprag units used with transfers. They are a single-sprag unit, a double-sprag unit, and an air-operated, double-sprag unit. They all work in almost the same way. This type transfer is much like the one we just discussed. The main difference is that a sprag unit is used instead of the hand-operated sliding gear or clutch on the front output shaft.

The sprag is a steel block shaped to act as a wedge in the complete assembly. In some units, there are 42 sprags assembled into an outer race and held in place by two springs. The springs fit into the notches in the ends of the sprags and hold them in place. The outer race is in the driven gear on the front output shaft. The inner race is on the front output shaft.

Now, let's see how a single-sprag unit operates. During normal operation, the front and rear wheels are turning at the same speed. The outer race of the sprag unit (in the driven gear) turns a little slower than the inner race (on the front output shaft). This prevents the sprags from wedging between the races. No lockup takes place, and the front wheels turn freely; they are not driven. However, if the rear wheels start to slip and turn faster than the front wheels, the outer race tries to turn faster than the inner race. When this happens the sprags wedge or jam between the two races. The two races now turn as a unit and provide driving power to the front wheels. As soon as the rear wheels quit slipping and start to turn the same speed as the front wheels, the sprags release.

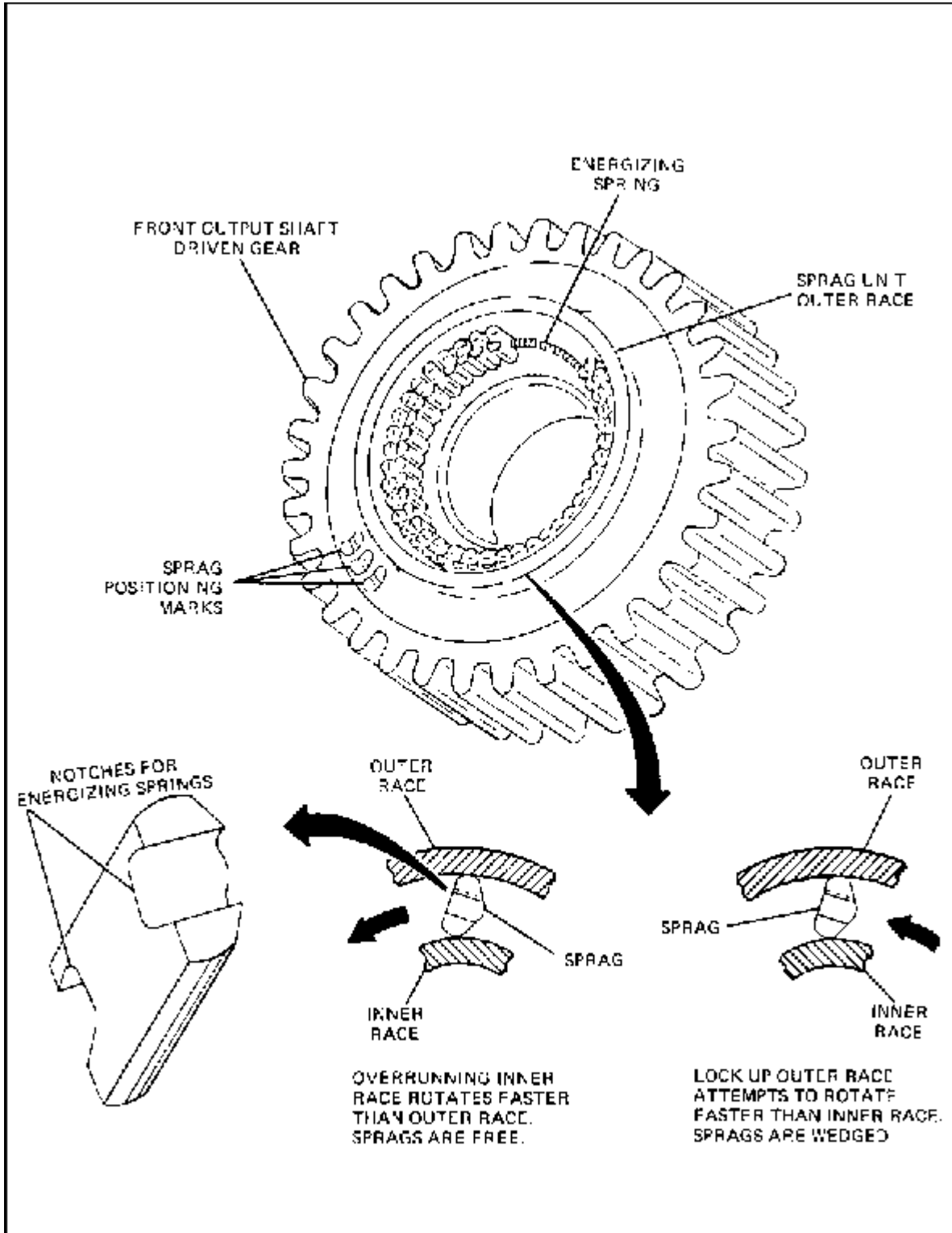

FIGURE 27. TRANSFER ASSEMBLY SPRAG UNIT.

In reverse, it is necessary to lock out the single-sprag unit. The turning is reversed; this means that we cannot drive through the sprag unit. The lockout is done through a linkage to the transmission that shifts a reverse shift collar in the transfer. As the reverse shift collar is shifted, internal splines in the collar mesh with external splines on the reverse shift driven gear and on the front output gear so there is a solid drive around the sprag unit.

The double-sprag unit operates the same way as the single-sprag in forward speeds. The difference between the two units shows up in reverse. In the double-sprag unit, a second sprag unit has been added which operates only in reverse.

When the shift is made to reverse, the forward sprag unit is locked out, almost exactly the same as the single-sprag unit. However, the reverse-sprag unit now comes into operation. The front wheels drive, in reverse, when the rear wheels start to slip. The shift from one sprag unit to the other is done by a linkage to the transmission. This shifts a reverse shift collar in the transfer. As the reverse shift collar is shifted, internal splines (or teeth) in the collar unmesh from the external splines on the outer race of one sprag unit. It then meshes with the external splines on the other sprag unit.

Another type sprag unit is the air-controlled, double-sprag unit. This unit does the same job as the double-sprag unit we just discussed. The main difference is an air valve on the transmission low and reverse shifter shaft. This valve automatically shifts the sprag unit to forward or reverse whenever the transmission is shifted to low or reverse.

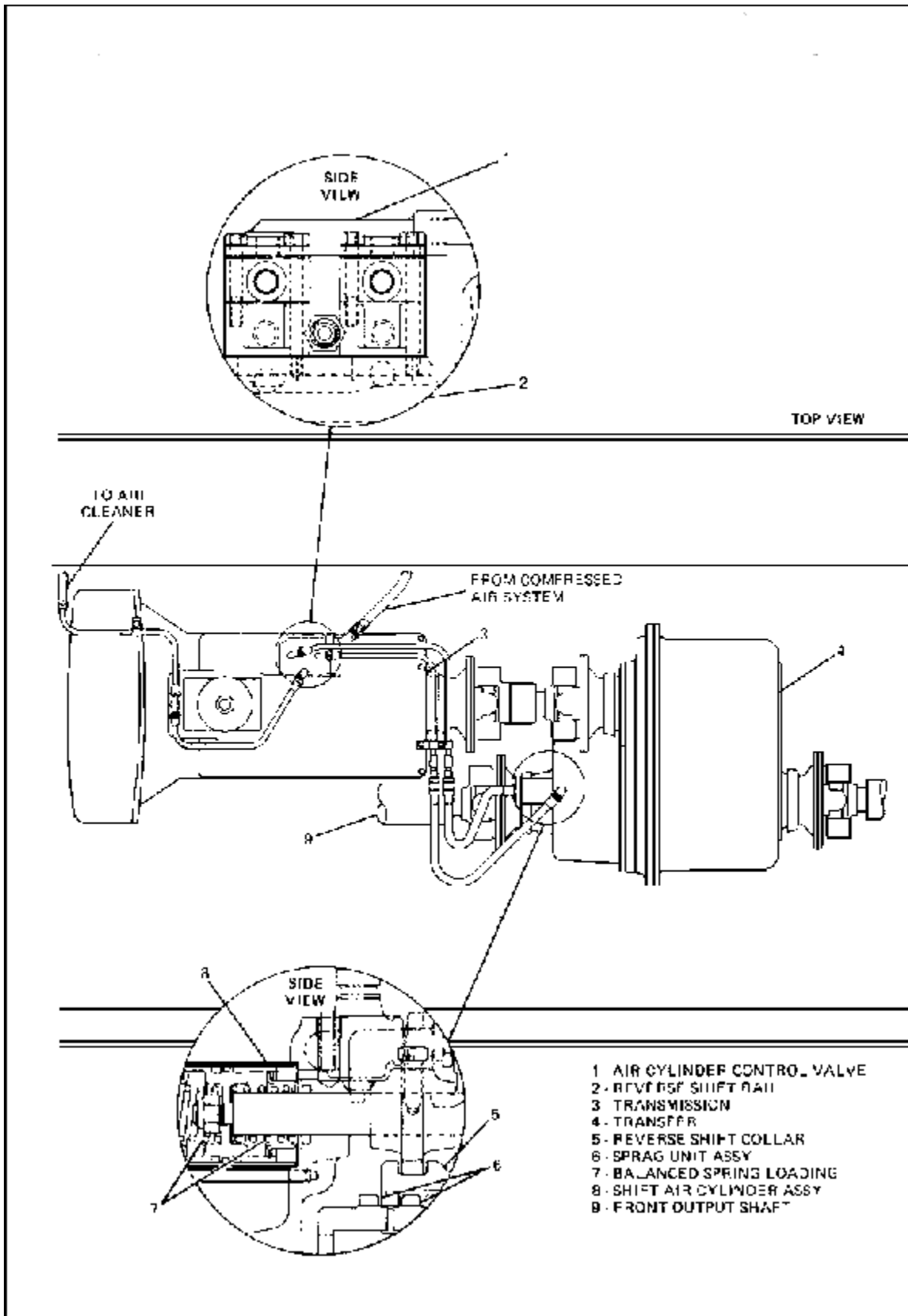

FIGURE 28. AIR-CONTROL DIAGRAM OF TRANSMISSION AND TRANSFER ASSEMBLY USING AN AIR-CONTROLLED, DOUBLE-SPRAG UNIT.

This illustration shows an air-control diagram of the transmission and transfer assembly using an air-controlled, double-sprag unit. This type is used in the 5-ton truck. Now let's take a look at what happens when there is compressed air in the system, and the transmission is in a forward or neutral position. The air cylinder control valve will admit air under pressure from the compressed air system into the shift air cylinder assembly. The air is then admitted to the forward-shift side of the spring-balanced piston in the cylinder. This moves the piston and causes engagement of the forward sprag unit. When the transmission is shifted into reverse, the air cylinder control valve admits air to the opposite side of the piston. This causes engagement of the reverse sprag unit. When the forward sprag unit is engaged, the front wheels will freewheel or turn only in a forward direction. If the reverse sprag unit is engaged, the front wheels cannot be turned in a forward direction. A parked vehicle, with air pressure in the system and the transmission in neutral, cannot be pushed backward until the transmission is shifted to reverse.

The transfer uses the dip or splash type of lubrication system. The gears are in the transfer case, and the case is filled with gear oil (GO 90 in warm weather). As the gears operate, they turn in the oil and no pressure is used. The turning gears will throw the oil onto the shafts and into the bearings. The oil is kept from leaking from the case by seals around the input and output shafts.

PRACTICE EXERCISE

1. What type of sprag unit is used on the 5-ton truck?
 - a. Single sprag
 - b. Double sprag
 - c. Air-controlled double sprag

2. What drives the mainshaft constant-mesh gear in the transfer?
 - a. Idler shaft constant-mesh gear
 - b. Drive shaft sliding gear
 - c. Mainshaft sliding gear

3. What type lubrication system is used in the transfer case?
 - a. Full force
 - b. Dip or splash
 - c. Force and splash

4. The sprags used in a sprag unit are steel
 - a. blocks.
 - b. balls.
 - c. rollers.

5. Which of the following is a purpose of the transfer case?
 - a. Provide gear reduction
 - b. Provide reverse gear
 - c. Provide overdrive

Lesson 5

Lesson 5

This page intentionally left blank.

ANSWERS TO PRACTICE EXERCISE

1. c (page 107)

2. c (page 101)

3. b (page 107)

4. a (page 103)

5. a (page 96)