

**United States Army Combined Arms Support Command**

**WHEELED VEHICLE ELECTRICAL SYSTEMS**

**(PART I)**

**SUBCOURSE NO. OD1002**

**US Army Ordnance Center and School**

**Aberdeen Proving Ground, Maryland**

**Five Credit Hours**

**GENERAL**

The Wheeled Vehicle Electrical System (Part I) Subcourse, part of the Light Wheel Vehicle Mechanic MOS 63B Skill Level 3 course, is designed to teach the knowledge necessary for performing tasks related to maintenance and repair of wheeled vehicle electrical systems. Information is provided on the fundamentals of automotive electrical systems, to include circuits, batteries, and the fundamentals and use of electrical test equipment. This subcourse is presented in three lessons, each lesson corresponding to a terminal objective as indicated below.

**Lesson 1: INTRODUCTION TO AUTOMOTIVE ELECTRICITY**

**TASK:** Describe the fundamentals of alternating current (AC) and direct current (DC) electricity as applied to automotive equipment.

**CONDITIONS:** Given information on the history and theory of electricity; characteristics of conductors and insulators; current, voltage, and resistance and their relationship; AC and DC; magnetism and induction; electrical symbols and circuits; and common circuit defects.

**STANDARDS:** Answer 70 percent of the multiple-choice items covering introduction to automotive electricity.

## **Lesson 2: AUTOMOTIVE BATTERIES**

**TASK:** Describe the construction, operation, and maintenance of automotive batteries.

**CONDITIONS:** Given information on the construction, operation, and rating of batteries; methods of connection; and maintenance procedures.

**STANDARDS:** Answer 70 percent of the multiple-choice items covering automotive batteries.

## **Lesson 3: FUNDAMENTALS OF ELECTRICAL TEST EQUIPMENT**

**TASK:** Describe the purpose, construction, and operation of electrical test equipment.

**CONDITIONS:** Given information on voltmeters, ammeters, and ohmmeters; low-voltage circuit testers; multimeters; and simplified test equipment for internal combustion engines (STE/ICE).

**STANDARDS:** Answer 70 percent of the multiple-choice items covering electrical test equipment.

# TABLE OF CONTENTS

<b>Section</b>	<b>Page</b>
TITLE PAGE.....	i
TABLE OF CONTENTS.....	iii
ADMINISTRATIVE INSTRUCTIONS.....	v
GRADING AND CERTIFICATION INSTRUCTIONS.....	v
INTRODUCTION TO WHEELED VEHICLE ELECTRICAL SYSTEMS.....	vi
Lesson 1: INTRODUCTION TO AUTOMOTIVE ELECTRICITY	
Learning Event 1: Describe Principles of Electricity and Magnetism.....	1
Learning Event 2: Describe Fundamentals of Electrical Circuits and Symbols.....	17
Practice Exercise.....	29
Answers to Practice Exercise.....	30
Lesson 2: AUTOMOTIVE BATTERIES	
Learning Event 1: Describe Fundamentals of Automotive Batteries.....	31
Learning Event 2: Describe Maintenance Procedures for Automotive Batteries.....	48
Practice Exercise.....	61
Answers to Practice Exercise.....	62
Lesson 3: FUNDAMENTALS OF ELECTRICAL TEST EQUIPMENT	
Learning Event 1: Describe Principles of Meters.....	63
Learning Event 2: Describe Construction and Use of Low-Voltage Circuit Testers.....	79

<b>Section</b>	<b>Page</b>
Learning Event 3: Describe Construction and Use of Multimeters.....	84
Learning Event 4: Describe Construction and Use of Simplified Test Equipment/Internal Combustion Engine (STE/ICE).....	87
Practice Exercise.....	118
Answers to Practice Exercise.....	120
EXAMINATION.....	121

## **ADMINISTRATIVE INSTRUCTIONS**

### **SUBCOURSE CONTENT**

This subcourse contains three lessons, each related to wheeled vehicle electrical systems. An introduction presents an overall view of the subject. Each lesson then covers a specific topic pertaining to wheeled vehicle electrical systems. Each lesson is followed by a practice exercise. An examination covering the three lessons is provided at the end of the subcourse.

#### Supplementary Requirements

**Materials Needed.** You will need a No. 2 pencil and paper to complete this subcourse.

**Supervisory Assistance.** There are no supervisory requirements for completion of this subcourse.

**References.** No supplementary references are needed for this subcourse.

## **GRADING AND CERTIFICATION INSTRUCTIONS**

### **INSTRUCTIONS TO THE STUDENT**

This subcourse has an examination that consists of 20 multiple-choice test items covering three lessons. You must score a minimum of 75% percent on this test to meet the objective of the subcourse. Answer all questions on the enclosed ACCP examination response sheet. After completing the examination, place the answer sheet in the self-addressed envelope provided and mail it to the Institute for Professional Development (IPD) for scoring. IPD will send you a copy of your score.

Five credit hours will be awarded for successful completion of this subcourse.

## INTRODUCTION TO WHEELED VEHICLE ELECTRICAL SYSTEMS

The electrical systems of military wheeled vehicles are well designed and constructed. With few exceptions, they are much like the systems used on civilian-type vehicles. The biggest difference is that 24-volt systems are used on military vehicles and 6- or 12-volt systems on civilian types. Also, the electrical systems on most military vehicles are waterproof.

Although these systems are well made, they still give some trouble, and they are systems that most wheeled vehicle repairers understand the least.

One of your jobs is the maintenance of these systems. While this is not difficult, it does take some "know-how."

This subcourse will familiarize you with these systems and will provide you with the "know-how" you need.

## LESSON 1

### INTRODUCTION TO AUTOMOTIVE ELECTRICITY

#### TASK

Describe the fundamentals of AC and DC electricity as applied to automotive equipment.

#### CONDITIONS

Given information on the history and theory of electricity; characteristics of conductors and insulators; current, voltage, and resistance and their relationship; AC and DC; magnetism and induction; electrical symbols and circuits; and common circuit defects.

#### STANDARDS

Answer 70 percent of the multiple-choice items covering introduction to automotive electricity.

#### REFERENCES

TM9-8000

#### Learning Event 1:

#### DESCRIBE PRINCIPLES OF ELECTRICITY AND MAGNETISM

#### INTRODUCTION

During the past 100 years, electricity became more important to man as each year went by. Today, in our homes, we depend on it for light, heat, and music. It provides power to operate water pumps, tools, kitchen appliances, and many other household items. Outside of the home, we also depend on electricity for many things. The family car is a good example. It uses electricity for lights, music, heat, and to make the engine run.

## **Lesson 1/Learning Event 1**

Most of the time we simply flip a switch to make electricity work for us. In a house, you use a switch to turn the lights or radio on. You do the same thing in your car. If the electricity does not do the work it is supposed to do when you move the switch, you usually need to get help from a repairer.

You, as a wheeled vehicle mechanic, are the repairer who will be called upon when the electrical systems of Army vehicles do not work. You will need to find out what is wrong, first, and then correct the trouble.

Each of us realizes how much we depend on electricity in our day-to-day activity. Without it, there would be no electric lights, heat, refrigeration, and so forth.

The military vehicles you will be working on must have electricity for many purposes such as ignition, lights, blower fans, and so forth.

Therefore, it is easy to see that a wheeled vehicle mechanic must have a working knowledge of electrical circuits to keep the equipment in good operating condition.

To do your job, you will have to know what electricity is, how it is used, and how electrical items work. This lesson will give you the information to understand what electricity is and how it can be made to do work for us.

### **COMMON KNOWLEDGE OF ELECTRICITY**

To begin with, let's review some of the things commonly known about electricity.

Normally, closing a switch is all it takes to make it work.

It is available from several sources, such as flashlight batteries, storage batteries like the ones used in cars, and generators ranging from hydroelectric plants to car generators.

We know electricity can cause a shocking sensation if it touches our bodies. We also know that, as the amount of electricity increases, the shock we feel gets worse.

It can do work. Today, it is one of our most important sources of energy.

We also know that wires or other connections are needed between the source of electricity and the appliance to be operated.



## SCOPE OF THIS LESSON

The complete study of electricity is a wide and complicated field. Even now, a lot of questions are unanswered and there is still a lot to learn. This lesson is not designed to teach you all there is to know about the subject. The information in this lesson will enable you to understand automotive electricity so that you know what it is, what it is supposed to do, how it does it, and how to determine what is wrong if there is trouble.

## HISTORICAL MILESTONES

The word "electricity" comes from the Greek word "elektron" which means amber. More than 2,500 years ago, Thales, a famous Greek, found out that electricity existed. Thales noticed that after he rubbed a piece of amber with a woolen cloth, the amber would attract lightweight items like dust, straws, feathers, and lint. This was because the amber had become electrically charged. Thales knew nothing about electricity, so he thought that this happened only with amber.

In 1733, a French scientist named Dufay found out that if a piece of glass was rubbed with cat's fur, the glass and the cat fur would become charged or electrified. He also found out that the charged glass would attract certain things that the fur would repel or push away. From this experiment, he correctly decided there were two kinds of electricity that were directly opposite.

Benjamin Franklin decided the two kinds of electricity should be named POSITIVE and NEGATIVE. They are also commonly referred to as plus and minus and are shown as (+) and (-). "Positive," "plus," and "+" refer to one kind of electrical charge; "negative," "minus," and "-" refer to the opposite charge.

Like charges repel each other, and unlike charges attract. Thus, if we have two items that have positive charges, they will repel or push away from each other. The same action occurs if the items have negative charges. On the other hand, if we have one item with a positive charge and another item with a negative charge, they will attract or pull together.

For many years it was believed that only such things as glass, amber, silk, and cat's fur could be electrified or charged. We know now, however, that under certain conditions all substances can be electrified.

## Lesson 1/Learning Event 1

### MATTER AND THE ATOM

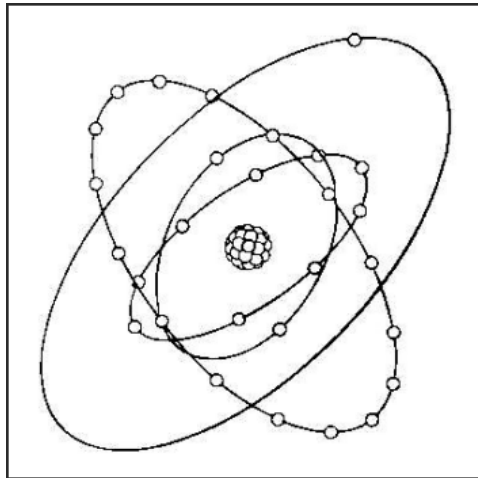
The mystery of electrification and the positive and negative charges was finally solved by studying the construction of matter. "Matter" is any substance that has weight and occupies space. Examples of matter are the air we breathe, water, cars, clothing, and so forth. To give you an idea of what electricity really is, so that you will be able to predict its action in automotive electrical circuits, we need to take a brief look at the construction of matter.

Imagine that you could take some form of matter, such as a rock, and break it down into the smallest particles that it can exist in and still be the original substance that you started with. These tiny particles are known as molecules.

Actually, you would not be able to do this, for as you continued to crush the rock you would finally end up with particles of dust, and just one of the small dust particles would contain thousands of molecules.

Scientists have discovered that any molecule contains one or more building blocks known as atoms. Each atom is an element. There are about 100 different kinds of atoms or elements. Some are metal, such as copper, iron, and gold. Others are nonmetallic, such as oxygen, hydrogen, and sulfur. While an element by itself is matter, different kinds of matter are formed by mixing elements. When two or more elements are mixed, we get matter that is known as a compound. For instance, a molecule of water is formed when two hydrogen atoms are joined with one oxygen atom. Therefore, water is a compound.

The secret of electrification was not discovered until scientists finally discovered that atoms are made up of three smaller particles. These particles are electrons, protons, and neutrons. The protons have a positive charge, electrons have a negative charge, and neutrons are neutral (have no charge). Figure 1 shows what we believe the atom looks like.



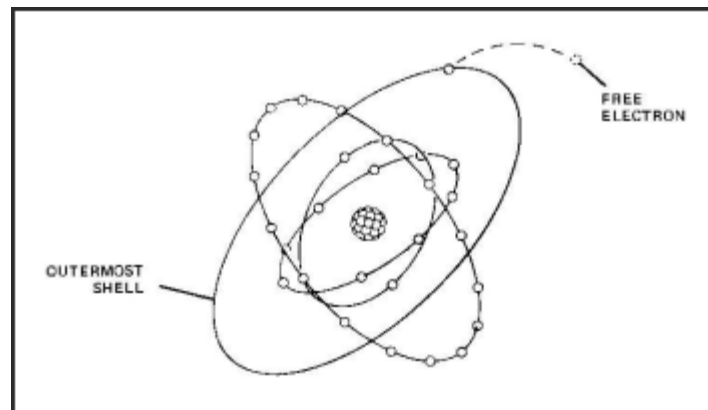
**FIGURE 1. COPPER ATOM.**

As an example, we will use one atom of the element "copper." Imagine that we have a magnifying glass that is able to magnify the atom so it appears to be one hundred million times larger than its actual size. This makes it look to be about 1 inch in diameter. We can now easily see that the atom has a central body, the nucleus. We can also see there are 29 smaller particles—electrons—rapidly circling around the nucleus, each one moving in a different path.

Now, imagine that we are able to magnify this copper atom even more, so that only the nucleus fills the viewing area. The nucleus now looks like a bunch of grapes. It actually consists of 64 particles bound tightly together, 29 of which are protons and the other 35 are neutrons.

All atoms in any one element are exactly alike. They have the same number of electrons, protons, and neutrons; they are all the same size; and all weigh the same. On the other hand, atoms from different elements are completely different. The atoms from each element contain an equal number of electrons and protons. Recall that our copper atom contains 29 electrons and 29 protons.

## Lesson 1/Learning Event 1



**FIGURE 2. FREE ELECTRON.**

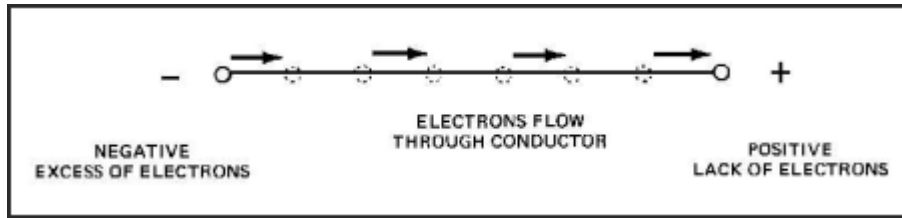
Now, let's go back to our magnifying glass and reduce its power so that we can see several atoms of copper in the viewing area. You can now see that some electrons moving in the outer circles of the atoms do not always stay in the same atom. Instead, they move haphazardly from atom to atom. They are known as free electrons, and they are the ones we are most interested in for our study of automotive electricity.

As some of the free electrons move out of their orbits (paths), the atom will have more protons than it does electrons. Since the protons have a positive charge, this gives the atom a positive charge. If the free electrons move to an atom that already has enough electrons, that atom will be negatively charged, since it will have a surplus of electrons. A negatively charged body repels electrons while a positively charged body attracts electrons.

### **ELECTRON MOTION**

In automotive electricity, we are most interested in the mass movement of electrons through an item, such as a wire. Such a movement of electrons is known as **ELECTRIC CURRENT** just as the flow of water in a stream is known as current.

When there is a surplus of electrons at one end of a wire and a shortage of electrons at the other end, electrons will flow from the surplus to the shortage. Since a surplus of electrons is a negative charge and the shortage a positive charge, electric current then flows from negative to positive.



**FIGURE 3. ELECTRON MOTION.**

When an electron leaves the negative source, this same electron does not just speed through the wire. Instead it strikes another electron and knocks it loose from its atom. This loosened electron then strikes another electron knocking it free. As one electron knocks another loose, it replaces the one it knocked out. This occurs as a chain reaction throughout the entire length of the wire.

To illustrate this action, imagine that you have a pipe filled with marbles from end to end. If you push a marble in one end of the pipe one marble will pop out the opposite end. As soon as the marble presses on the column of marbles, its movement is transmitted all the way through the pipe. The pipe is comparable to a wire and the marbles to electrons.

## **ELECTROSTATICS**

## **MAGNETISM**

We know that it takes mechanical energy to crank an engine, yet it is done by supplying electrical energy to a starter motor from the vehicle battery. Also, we know that by using mechanical energy from the engine to drive the generator, we are able to produce electricity. Magnetism is the connecting link between mechanical energy and electrical energy. To understand why it is, we must first learn some basic facts about magnetism.

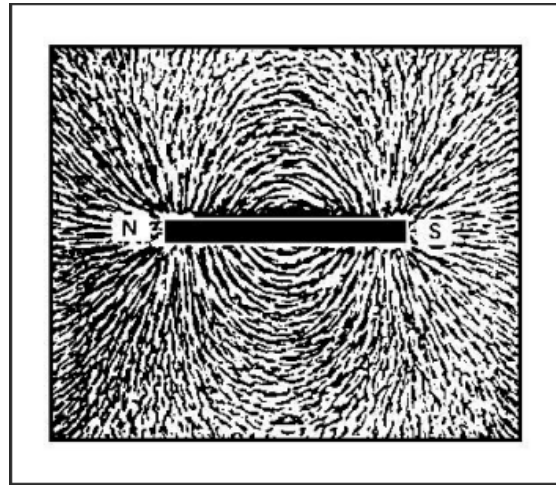
## Lesson 1/Learning Event 1

Magnetism is an invisible force that attracts iron and steel. It was first noticed in a particular type of stone called magnetite that is a natural magnet. Magnetite was first used as a compass to tell directions for sailors on the ocean or travelers in unfamiliar country. This was possible because, if a piece of magnetite is suspended so it is free to rotate, it will turn so it points to the earth's magnetic north and south poles. One end always points to the north so this is called the north pole and the opposite end is called the south pole.

Pieces of magnetite, natural magnets taken from the earth, have little value now. Better magnets can be made from iron and steel by artificial means. Magnets that are made from soft iron are known as "temporary" magnets because they lose their magnetism quickly. Magnets made from steel are known as "permanent" magnets because they stay magnetized for a long time. Permanent magnets that most of us are familiar with are the bar- and horseshoe-shaped kinds. Let's discuss a few experiments with some permanent bar magnets to gain some knowledge of the invisible forces they possess.

- If a bar magnet is suspended by a thread, it will swing into a north-south direction with its ends pointing to the earth's magnetic poles. Like the magnetite, the end of the magnet toward the north is known as the north pole and the end to the south the south pole.
- If we obtain a second bar magnet and move its north pole toward the north pole of the suspended magnet we can see that the suspended magnet moves away from the second magnet. Likewise, if the south poles are moved close together, the suspended magnet will move away. Therefore magnetic poles that are alike repel each other.
- Now, let's move the south pole of the second bar magnet toward the north pole of the suspended magnet. Instead of moving away as it did before, the suspended magnet now moves toward the second magnet. In fact, if we allow the north and south poles of the magnets to come in contact, they stick together, and it takes considerable force to pull them apart. This last experiment then proves that unlike magnetic poles attract each other.

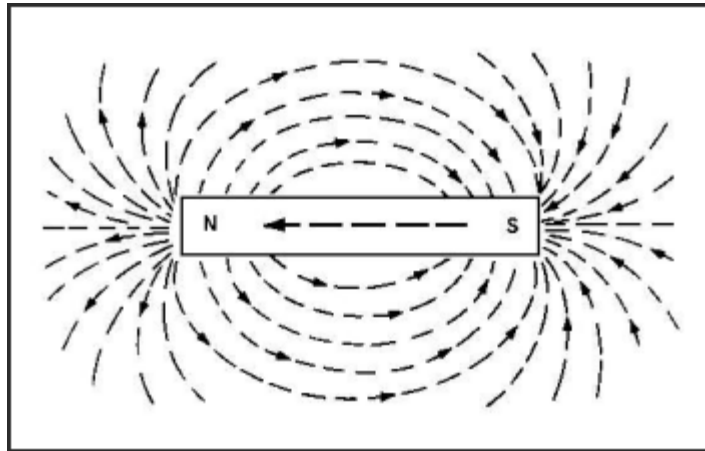
The surrounding space around a magnet that is affected by the magnet's invisible force is known as a MAGNETIC FIELD. The magnetic field is often demonstrated by sprinkling some iron filings on a piece of paper that has been placed on a tabletop. A bar magnet is then dropped into the center of the paper. Of course, a large number of the filings are immediately attracted and moved about by the magnet.



**FIGURE 4. MAGNETIC FIELD.**

If the tabletop is gently tapped, the filings will move about and arrange themselves in a definite pattern of lines about the magnet. The pattern shape is determined by the forces of the magnetic field around the magnet. Notice that the lines are clear near the magnet and get less distinct farther away. This is because the magnetic field is strongest near the magnet and gets weaker with distance.

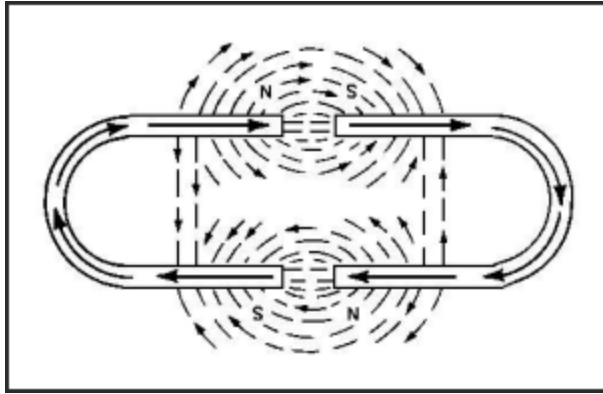
## Lesson 1/Learning Event 1



**FIGURE 5. MAGNETIC LINES OF FORCE.**

The lines formed about the magnet are known as **LINES OF FORCE**. Actually, the lines of force extend all the way around the magnet instead of just in a flat plane as shown by the filings on the paper. This is shown by the lines drawn at the end views of a bar magnet shown here. Note that arrowheads have been placed on the lines of force here to indicate direction of movement. Also note that the arrows indicate that the lines of force leave the north pole and enter the south pole.

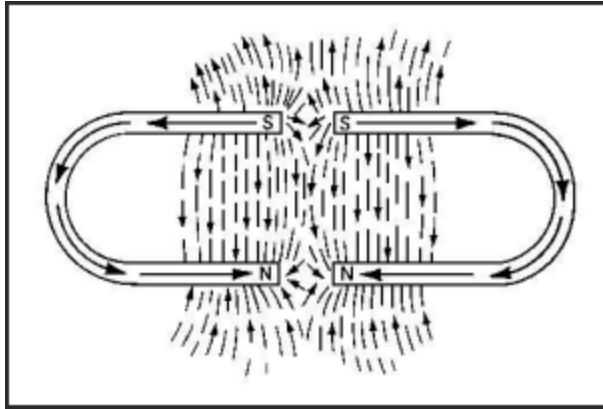




**FIGURE 6. UNLIKE POLES.**

It can be proved that the lines of force do have a direction of movement by using two magnets and iron filings. First, place the magnets in iron filings so unlike poles are facing. Notice that the lines of force between the unlike poles combine to increase the strength of the magnetic field between the two magnets. This indicates that the lines of force between unlike poles flow in the same direction.

## Lesson 1/Learning Event 1

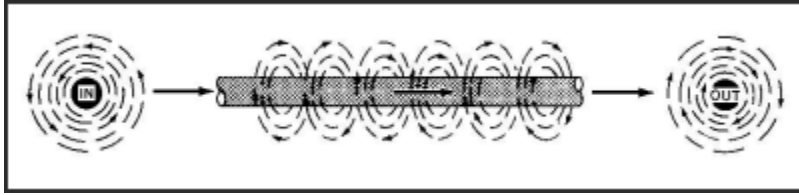


**FIGURE 7. LIKE POLES.**

Now, position the two magnets so the like poles are facing. Notice that the iron filings in the magnetic field do not mix. Instead they turn away from each other indicating they are moving in opposite directions, thus repelling each other.

## INDUCTION

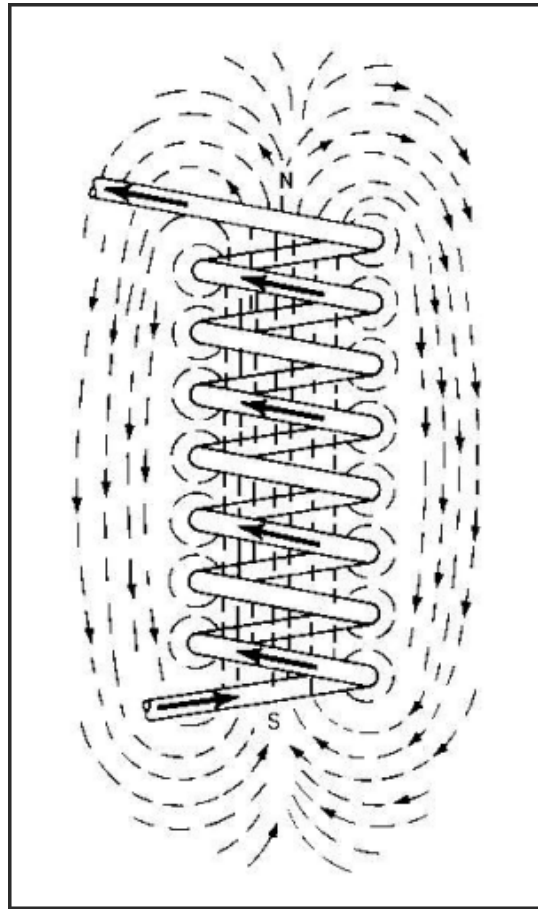
By now you may be thinking, so what does magnetic force have to do with electricity? Well, let's give this matter more consideration and find out what the connection is and how it may be used.



**FIGURE 8. ELECTROMAGNETISM.**

First, think about this experiment that is easily done. Pass a wire through a hole in the center of a piece of cardboard. With the cardboard level, sprinkle iron filings on it around the wire. Now connect the wire to a battery so it conducts current and tap gently on the cardboard. The filings will then form circles around the wire. This proves that a magnetic field circles the wire. A magnetic field created by electricity, such as in this experiment, is known as ELECTROMAGNETISM.

We can carry the experiment out farther and prove that the lines of force about the wire have direction and that the direction is affected by the direction of current flow. Start by placing a compass at various points in the magnetic field around the wire. You will notice that the compass needle always aligns with the lines of force, with the north pole of the needle pointing in the direction of the magnetic field. Now reverse the wires on the battery terminals so the current flows in the opposite direction. The north pole of the compass needle will also reverse direction, proving that reversing the direction of current in the wire reverses the direction of the magnetic field.

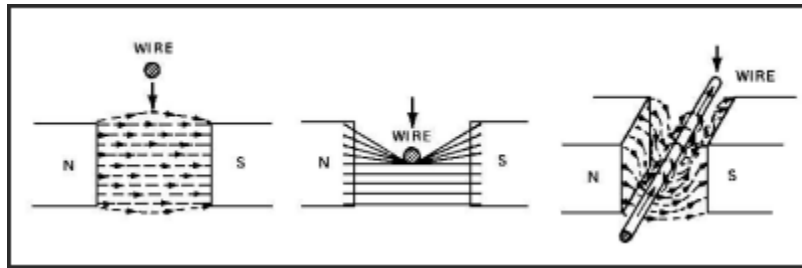


**FIGURE 9. LINES OF FORCE IN A COIL.**

An electromagnet is made stronger by increasing the amount of current flowing in the conductor or weaker by decreasing the current. It can be concentrated to make the magnetic field stronger in one area by winding the conductor into a coil. The more turns in the coil, the stronger the magnetic field in that area. Often, an iron core is placed inside the coil to make the magnetic field even stronger. This is possible because the lines of force travel through iron easier than they do through air.

The repelling and attracting forces of magnetic fields of electromagnets are used in electric motors and other devices to do mechanical jobs. In automotive vehicles, these jobs range from cranking the engine to opening or closing small contact points in a relay switch.

Now, let's see how mechanical force can be used in creating an electric current. Using a horseshoe magnet, a conductor (such as a copper wire), and a sensitive, current-indicating meter (such as a galvanometer), you can demonstrate this.



**FIGURE 10. ELECTROMAGNETIC INDUCTION.**

Connect the meter to the conductor and then move the conductor downward between the poles of the magnet. When this is done, the indicating needle on the meter will momentarily move away from zero indicating a surge of current flow. If the conductor is then held still in the magnetic field, the meter needle will not move from zero, indicating that there is no current flowing in the conductor. This shows the magnetic field causes free electrons to move only when the conductor is in motion, moving across the lines of force.

The amount of voltage and resulting current flow created (induced) in the conductor can be increased by several methods. The faster the conductor is moved across the lines of force, the greater the voltage. Also, increasing the strength of the magnetic field will increase voltage. Another method of increasing voltage is to wind the conductor into a coil so that several turns of the coil can be passed through the magnetic field at one time.

## Lesson 1/Learning Event 1

As you can see, to induce electricity in a conductor, we must have a magnetic field and motion. In automotive generators, mechanical energy from the engine is used to supply the motion. On some types of generators, the conductor is moved through a stationary magnetic field, while on others the magnetic field is moved and the conductor is stationary.

The induction principle is also used in TRANSFORMERS. A transformer is an electrical device that is used for stepping up or stepping down electrical voltage. The ignition coil of an automotive vehicle is actually a transformer that steps the 12- to 24-volt battery voltage up to the several thousand volts needed to ignite the fuel mixture. In the following paragraphs, we will discuss the construction and operation of transformers.

A simple transformer often contains an iron core and consists of two coils of wire. One coil is actually an electromagnet and is called the primary winding. The second coil is called the secondary winding.

If the primary winding is connected to a battery, current will flow through the winding causing a magnetic field to build up around the coil. As the field builds up, its lines of force move outward cutting across the coils of the secondary winding. The secondary winding will have a voltage induced in it as a result of the lines of force cutting across its coils. Now, if the ends of the secondary winding conductor were connected into a complete circuit, current would flow until the induced voltage dropped to zero.

When the primary winding is disconnected from the battery, the magnetic lines of force will collapse and disappear. As this happens, the lines of force move rapidly inward toward the primary winding. Again, the moving lines of force cut across the coils of the secondary winding inducing a voltage. This time the lines are moving in the opposite direction so the induced voltage causes current to flow in the opposite direction.

**Learning Event 2:**

**DESCRIBE FUNDAMENTALS OF ELECTRICAL CIRCUITS AND SYMBOLS**

**CONDUCTORS**

Atoms from different elements are not alike. Electrical current will flow through some materials easily but, in others, practically no electrons will flow. If current flows through a material easily, the material is called a CONDUCTOR.

A good conductor is a material that has a large number of free electrons. All metals are conductors of electricity, but some are better conductors than others. Examples of good conductors are silver, copper, and aluminum. Silver is a better conductor than copper, but copper is more widely used because it is cheaper. Since aluminum is light, it is used as a conductor where weight is a major consideration.

The ability of a material to conduct electricity also depends on its size. The greater its diameter and the shorter its length, the better it conducts. Conductors may be in the forms of bars, tubes, or sheets, but the most common form is wire. Many sizes of wire are used, from the fine hair-like wire in sensitive measuring instruments to the large bar-like wire used for carrying high current in power generating plants.

Most wire conductors that you will be working with on automotive vehicles are stranded wires. A stranded wire consists of many small wires twisted together to make one conductor. This makes them very flexible so they can be bent and fitted around vehicle components without breaking.

**INSULATORS**

If a material has so few free electrons that it blocks electron flow, it is called an INSULATOR.

No material known is a perfect insulator, but some materials are such poor conductors that for all practical purposes they are classed as insulators. Examples of insulators are porcelain, glass, air, rubber, oil, Bakelite, and certain kinds of enamel and varnish.

Insulators are used to make sure that the flow of electrons does not stray out of the path that has been provided with conductors. An example of this is the insulator used to anchor overhead electric lines to their utility poles. The insulators block the electrons to prevent them from flowing into the pole and into the ground.

## Lesson 1/Learning Event 2

In automotive vehicles, insulators must be used to keep the electrons or current in the proper path. Wire conductors are covered with insulating material, such as rubber, cotton, plastic, or enamel. Hard materials, such as fiberboard and Bakelite, are used in the ignition system and for switches where parts need to be mounted securely by a rigid insulator.

### CURRENT

Electric current, like the flow of water, can be measured. Water flowing in a pipe is measured by the number of gallons of water that flow per minute. Electric current is measured by units known as AMPERES. It takes more than six billion electrons moving past a given point in one second to make up one ampere.

A device known as an AMMETER is used to measure amperes.

While 1 ampere may sound like a lot, in automotive electricity it is considered a rather small amount of current. Some lights may require about 1 ampere, but the starter motor requires 100 amperes or more.

### VOLTAGE

As we said before, electron flow or current is caused by electron unbalance. In other words, when one end of a conductor has a positive charge and the other end has a negative charge, electrons will move to the positive end. The greater the difference in the amount of electrons at opposite ends of a wire, the greater the pressure will be that is pushing the electrons through the wire. This pressure is commonly known as potential difference, or VOLTAGE.

Voltage and its effect on electric current in a wire can be compared to pressure and its effect on water flowing in a pipe. When pressure is increased on water in a pipe, a greater volume of water will flow in a given period. If the voltage of an electrical circuit is increased, a greater number of electrons will move—more current will flow.

Voltage is measured with a VOLTMETER, which will be covered in detail later.



## RESISTANCE

When the voltage forces the current to flow in a wire, the electrons meet RESISTANCE. Resistance is caused by the friction of the electrons bumping into the atoms. If you rub your fingertips across a table, the friction causes heat. As you move your fingertips faster, the heat becomes greater. Likewise, electrons flowing through a wire cause heat. If the voltage is increased, current flow and the amount of heat are also increased. If the current flow is increased enough, the wire will become hot enough to literally burn up.

The heating action of current flow is one of the great uses of electricity. For an example, let's take a look at a light bulb.

The bulb contains a filament made of a material that has a lot of resistance to current flow and can withstand extreme heat. The filament ends are connected to two contacts at the base of the bulb. (Usually the metal part of the base serves as one contact.) The filament is then enclosed in glass, and most of the air is removed, because if air gets to the filament, it will burn up too easily.

Voltage from a battery or other source is applied to the two contacts at the base of the bulb. Current then flows through the filament causing it to get white-hot which produces light.

For the bulb to function properly the material in the filament, the size of the filament, and the amount of voltage supplied must be carefully balanced so just the correct amount of current will flow. If the current flow is too small, the filament will not get heated enough and the bulb will not glow brightly. If the current flow is too great, the filament will burn up.

Sometimes a special part known as a RESISTOR is placed in the electrical circuit to reduce the current flow. The action of the resistor can be compared to the restricting action of a water valve or faucet. Opening the valve more will cause more water to flow because there will be less resistance to the flow of water. Likewise, reducing the resistance in an electrical circuit will cause more electrical current to flow.

Resistors are usually made from carbon or special wire. Some resistors are "fixed"; that is, they are made so you cannot change the resistance as you can with the faucet in a water system. Resistors that you can adjust are known as "variable" resistors or RHEOSTATS. A rheostat usually has a movable contact that you can move along the length of a resistor. By moving the contact, you change the effective length of the resistor. The greater the distance the current travels to get through the resistor, the greater the resistance of the rheostat.

## **Lesson 1/Learning Event 2**

The amount of resistance that a resistor or any other conductor offers to current flow is measured in OHMS. A material has 1 ohm of resistance when 1 volt (pressure) will force 1 ampere of current to flow through it. Resistance is measured with an OHMMETER, which will be covered later.

### **RELATIONSHIP OF QUANTITIES IN AN ELECTRICAL CIRCUIT**

There is a definite relationship between voltage, resistance, and amperage that must be considered when maintaining automotive electrical systems. From the example of the light bulb, you can see that whether or not the bulb works as it should depends on the amount of current that is flowing through the circuit. From our study up to now, you can also see that a change in either the amount of voltage or the amount of resistance will change the amount of current flowing in a circuit. Here are some facts about changes in voltage, resistance, and amperage that you should remember.

If the voltage in a circuit is made higher and the resistance remains the same, the amperage (current) will also get higher. The reverse of this is also true--less voltage will cause less amperage.

If more resistance is put in an electrical circuit, the current is reduced whereas less resistance allows more current to flow.

Resistance can be changed by changing the length or diameter of a wire, by using a rheostat, or by using different sizes of fixed resistors.

### **ALTERNATING CURRENT**

The electricity that comes to your home for operating the lights, refrigerators, and so forth, is ALTERNATING CURRENT (AC). It was given this name because the electrons move through the wire first in one direction and then in the opposite direction. Since current flows from negative (surplus of electrons) to positive (shortage of electrons), the generating plant producing an alternating current must be periodically changing the electrical charge. In this manner, the electrons are caused to move back and forth in the circuit instead of in a constant stream moving in one direction only.

This can be illustrated if we compare AC to the swinging pendulum of a clock. Current, like the pendulum, starts from one extreme point to the right or left and very slowly builds up to fastest speed at about one-half of its travel. Then, its speed begins to fall off until it comes to a complete stop for just an instant before swinging again in the opposite direction. AC is defined as a current that is constantly building up or falling off and periodically changing direction.

When the electron flow returns to the same point it started from, just as the pendulum completes its swing to and fro, this completes one cycle. The number of cycles that occur each second is known as the frequency of the current. The current supplied to your home, in this country, has a frequency of 60 cycles per second. Lately, the term "Hertz" is often used instead of cycles. So remember that both "60-Hertz AC" and "60-cycle AC" mean the same thing.

### **DIRECT CURRENT**

Electric current that flows in one direction only is called DIRECT CURRENT. The term direct current is commonly shortened to DC. Batteries cannot reverse the electrical charge, as must be done to produce AC, so they always supply DC. Since automotive vehicles use batteries, most electrical circuits that you will be working on use DC.

In automotive electricity, we are sometimes faced with the problem of changing AC to DC. For instance, if the vehicle is equipped with an AC generator, that current cannot be used to charge the vehicle battery. In this case, the AC must be changed to DC.

Parts called RECTIFIERS or diodes are used to change AC to DC. A rectifier works like a one-way check valve in a water system. Water or current can flow through the check valve or rectifier in one direction, but flow is blocked in the opposite direction. Rectifiers are made from materials that are constructed in such a manner that the atoms allow electrons to move in one direction but not the other.

## **Lesson 1/Learning Event 2**

### **SYMBOLS**

Automotive repair manuals use several methods to present all the information that you need to repair electrical systems. For instance, some of the information is presented through written words, but a lot is presented through drawings and the use of SYMBOLS. A symbol is a sign or figure that stands for something else. Symbols are especially useful in electricity, since they can be used to show many things that are actually invisible.

Before you can read and obtain the needed information from electrical drawings (schematic diagrams), you must know the meaning of the symbols that are used. Let's take a look at some common symbols that are used in schematic diagrams of an automotive electrical circuit.

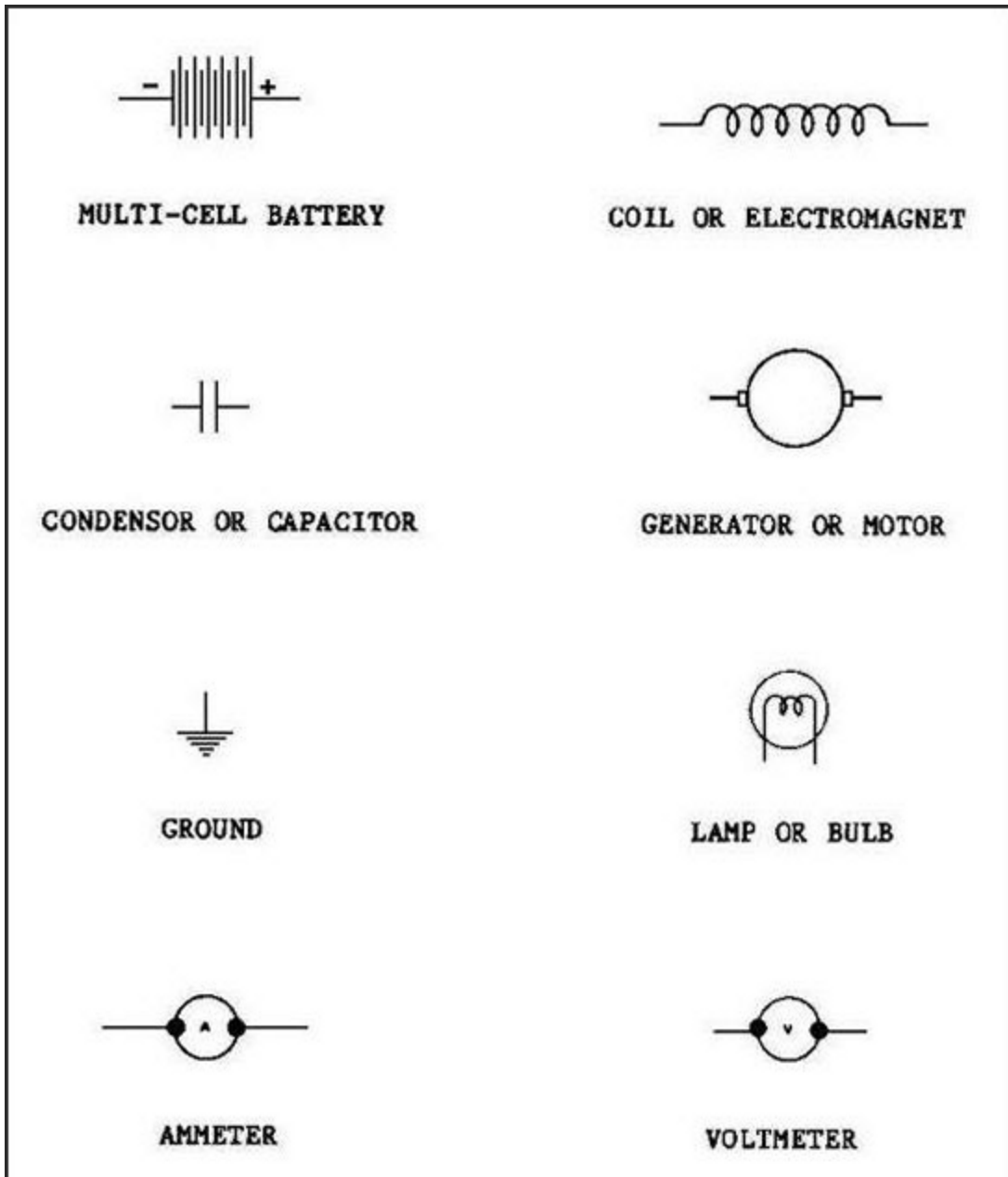


FIGURE 11. COMMON ELECTRICAL SYMBOLS.

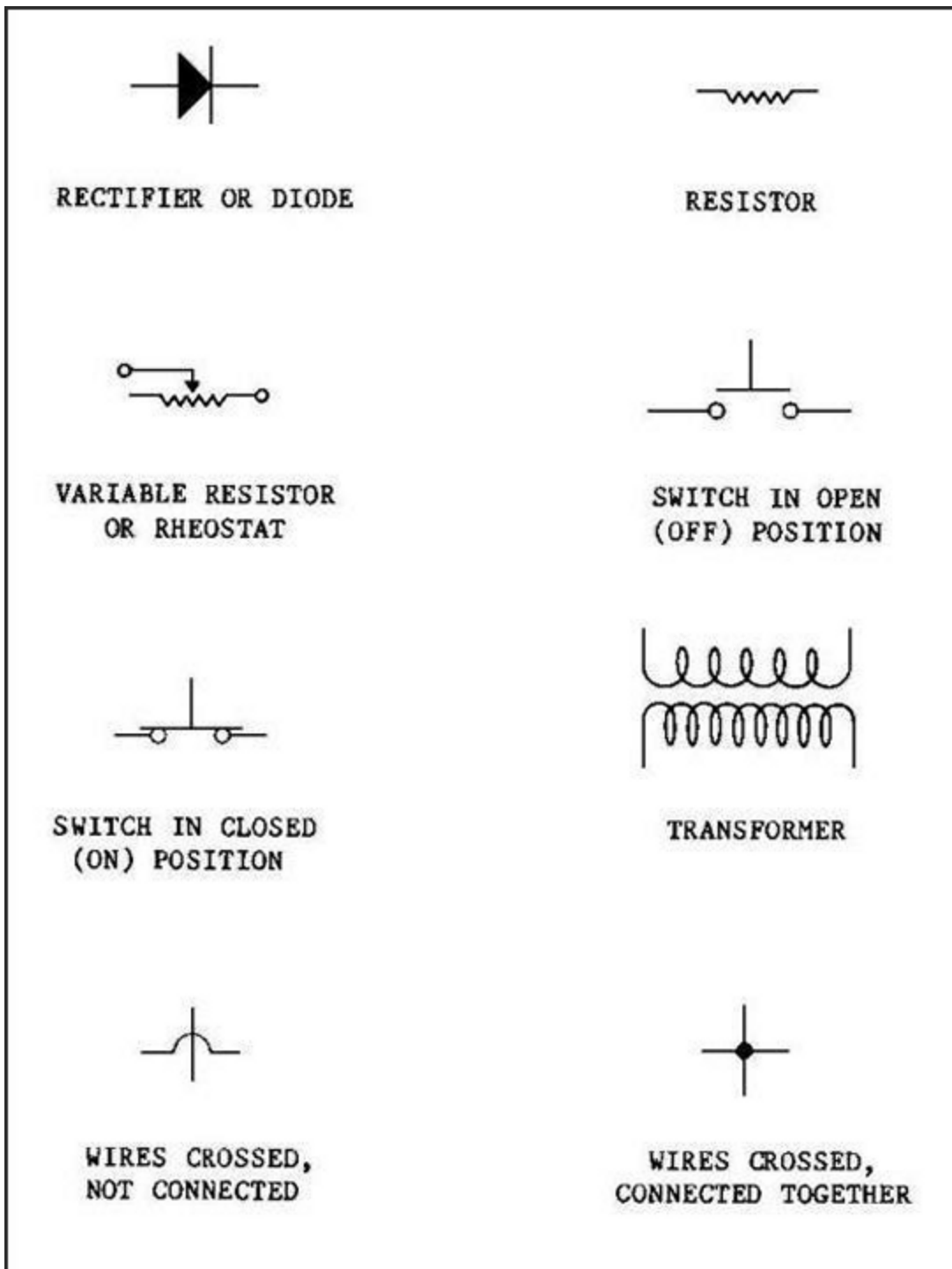
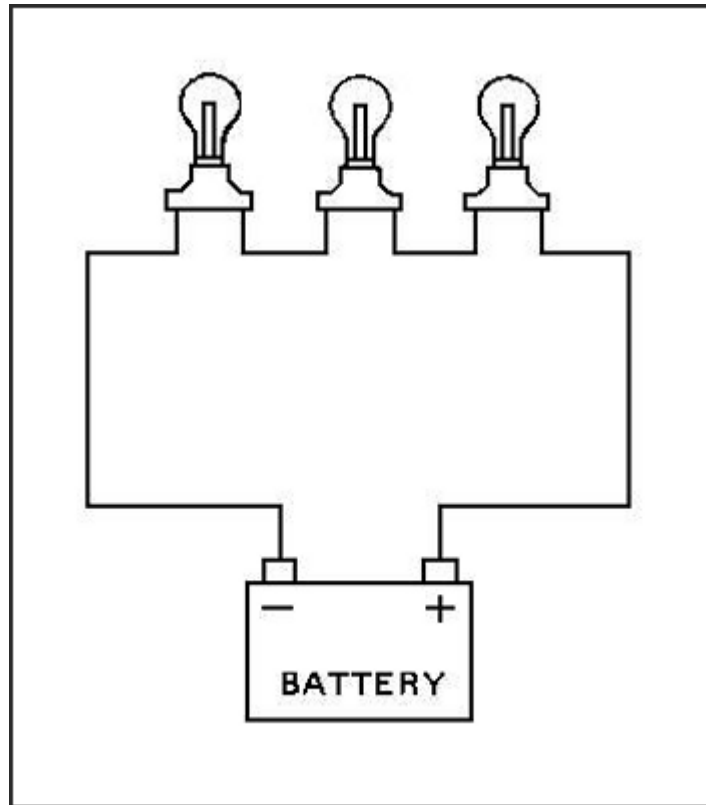


FIGURE 11. COMMON ELECTRICAL SYMBOLS (CONTINUED).

**TYPES OF CIRCUITS**

Electrical circuits can be laid out in series, parallel, or series-parallel. To troubleshoot an electrical circuit, you must be able to identify the way it is laid out and understand how current flows in the circuit.



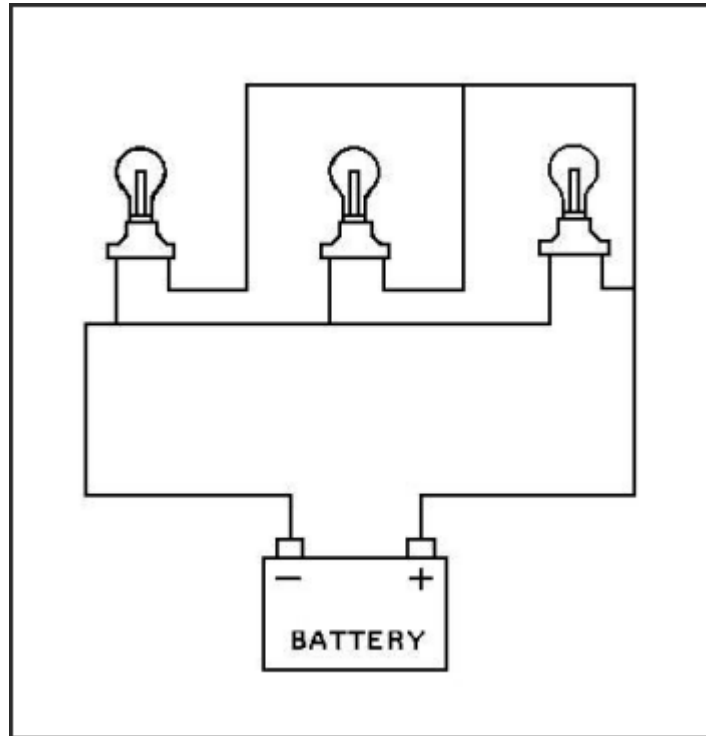
**FIGURE 12. SERIES CIRCUIT.**

First, let's take a look at the **SERIES CIRCUIT**. A good example of this circuit is a string of series-connected Christmas tree lights. Can you recall a time when all the bulbs on a light set quit working because one bulb burned out? This is what happens when a series circuit is used.

The reason for all the lights going out can be easily explained by the schematic diagram of the light set. Notice there is only one wire connected between each bulb. By following this electrical path, the current must flow from the power source to the first bulb, through that bulb filament, to the next bulb, through its filament, and so forth, in order to get back to the power source.

## Lesson 1/Learning Event 2

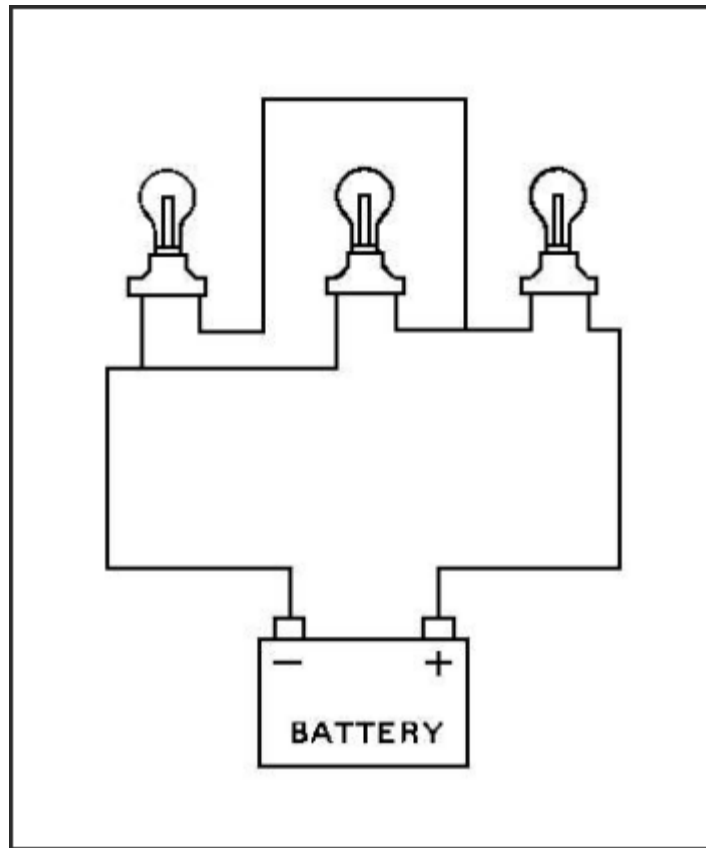
If the electrical path is broken at any point, no current will flow and all the lights will go out. This happens when the filament in any one of the bulbs burns out or a wire breaks. Actually, a break in the circuit has the same effect as turning a switch off. To sum this up, we can say that in the series circuit a number of items are connected together in such a manner so the current has only one path to follow.



**FIGURE 13. PARALLEL CIRCUIT.**

In the PARALLEL CIRCUIT, there is more than one path for the current to follow. This is the kind of circuit used when bulbs in a string of Christmas tree lights are connected together by two wires. Notice that each bulb provides a separate path for the current flow. If one bulb burns out, this will not affect the others. The parallel circuit is the most commonly used circuit in automotive electricity.





**FIGURE 14. SERIES-PARALLEL CIRCUIT.**

The **SERIES-PARALLEL** circuit is a combined series and parallel circuit. This is illustrated by the three-bulb circuit here. All the current flowing in the circuit must go through bulb 1. There is only one path here so this is the series part of the circuit. But, on the other side of bulb 1, the electrical path divides. There, part of the current flows through bulb 2 and the remainder through bulb 3. Then, the paths join again to form a single path to the power source. The divided paths through bulbs 2 and 3 are the parallel part of the circuit.

### **ELECTRICAL CIRCUIT DEFECTS**

Circuits are also described as being grounded, shorted, or open or as having a high-resistance connection. These terms refer to conditions that exist in a circuit and usually describe a defect. Let's go into these terms in more detail so you will grasp the full meaning of each.

A **GROUND**ED circuit exists when defective insulation allows a conductor, such as a wire, to touch the vehicle frame. This probably causes most of the electrical fires on automotive vehicles.

## Lesson 1/Learning Event 2

In automotive circuits only one insulated wire to the battery is used. One battery terminal, usually the negative, is connected to the vehicle frame by a ground cable, and the frame serves as one conductor. When the switch is closed, current flows from the negative terminal of the battery, through the frame to the bulb, then through an insulated wire, light switch, and to the positive terminal of the battery.

Now, let's imagine that the insulation wears off exposing a bare spot on the wire between the light switch and the bulb. Let us further imagine that the exposed wire touches the frame. Battery current can now flow from the frame to the touching wire, through the switch, and back to the battery. Before, the high resistance of the bulb prevented a large amount of current from flowing. With the wire grounded on the frame, current can bypass the bulb, and the circuit now has very little resistance. As a result, so much current will flow through the wire that it will get hot enough to melt and can set fire to any nearby flammable objects.

A **SHORT CIRCUIT** occurs when two exposed wires touch. This will let the current flow in the circuits for both wires even though the switch is closed in only one circuit. You can realize the results of this defect if you will imagine that a car has a short circuit between the wires to the tail and stoplights. When the taillight switch is turned on, battery current from the frame divides and flows through both lights and then joins to form one path at the short circuit. So both lights are burning even though the stoplight should not be.

When an **OPEN CIRCUIT** exists, no current flows. For example, a light circuit is open when its switch is off or open, when a wire conductor is broken, or when the bulb filament is burned out. An open circuit occurs in a circuit that is good when you turn off the switch. The other conditions are defects in a bad circuit.

A **HIGH-RESISTANCE CONNECTION** is usually the result of corrosion at a battery post, loose wires at any terminal, or frayed wires. (A frayed wire has some but not all of the strands of wire broken.) A high-resistance connection reduces the amount of current flowing so the circuit cannot work as it should. In a light circuit, for instance, the bulb filament would not glow as brightly as it should.

**PRACTICE EXERCISE**

1. The nucleus of an atom contains particles with
  - a. negative and positive charges.
  - b. positive and neutral charges.
  - c. neutral and negative charges.
  
2. A material that contains many free electrons is called
  - a. a compound.
  - b. a conductor.
  - c. an insulator.
  
3. Which of the following does not affect the strength of an electromagnet?
  - a. The amount of current flow
  - b. The number of turns in the coil
  - c. The direction of current flow
  
4. Which defect will prevent current flow?
  - a. Short circuit
  - b. Ground
  - c. Open circuit
  
5. The current in a circuit can be reduced by increasing the
  - a. resistance.
  - b. applied voltage.
  - c. diameter of the conductor.

## Lesson 1

### ANSWERS TO PRACTICE EXERCISE

1. b (page 4)
2. b (page 17)
3. c (page 14)
4. c (page 28)
5. a (page 20)

## LESSON 2

### AUTOMOTIVE BATTERIES

#### TASK

Describe the construction, operation, and maintenance of automotive batteries.

#### CONDITIONS

Given information on the construction, operation, and rating of batteries; methods of connection; and maintenance procedures.

#### STANDARDS

Answer 70 percent of the multiple-choice items covering automotive batteries.

#### REFERENCES

TM9-8000

#### Learning Event 1:

#### DESCRIBE FUNDAMENTALS OF AUTOMOTIVE BATTERIES

#### INTRODUCTION

In the first lesson you learned that electricity can be produced magnetically. Electricity is also produced chemically by means of a battery.

Batteries used in automotive vehicles supply electricity for cranking the engine, igniting the fuel mixture in the cylinders, and operating most accessories. In fact, cars as they are now designed could not operate without batteries. Understanding the batteries and knowing how to keep them in good condition are vital parts of good automotive maintenance. Present-day cars would be quite helpless and of no use without the electricity furnished by a good battery that is properly connected.

## Lesson 2/Learning Event 1

We, as mechanics, must know a great deal about batteries to keep them in good working order. Automotive batteries need daily attention from the operator plus some frequent maintenance performed by the operator and the mechanic, as well as special attention under certain conditions. To do your part, you will need knowledge of batteries and the procedures involved in their maintenance.

A battery is nothing more than two unlike conductors immersed in a special solution called electrolyte.

You can make a battery in a few minutes if you have a lemon, a paper clip, and a piece of uninsulated copper wire. Here is how it is done:

- Straighten out the paper clip and cut the copper wire so it is the same length as the paper clip. Stick both the clip and the wire deep into the lemon so they are close together but not touching. Now, if you touch the free ends of the wire and paper clip to your tongue, you will experience a slight tingle and a metallic taste.
- The tingle and the metallic taste are due to electrons passing through the saliva on your tongue. The lemon juice is the electrolyte solution; the steel paper clip and the copper wire are the two unlike conductors. Action of acid in the juice combining with the conductors causes an excess of electrons to build up on one conductor. When you touched your tongue to the conductors, you closed the circuit and electrons began to flow.

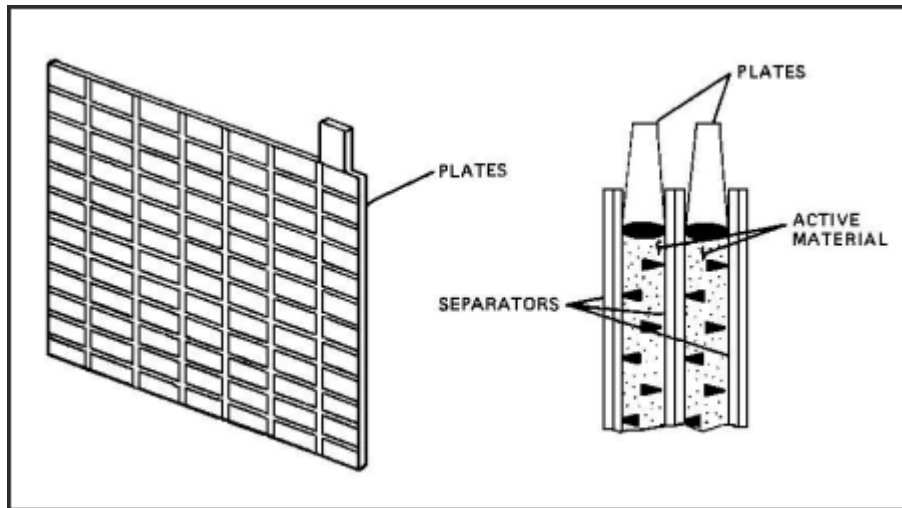
Almost everyone is familiar with the common flashlight battery (dry-cell battery).

The battery consists of a zinc cup-like container that is sealed at the top. A carbon rod is set in the middle of, and insulated from, the container. The rod extends out the top with its exposed tip covered by a metal cap. The cup is filled with a mixture of materials that make up a paste-like electrolyte. The carbon rod and the zinc case are the unlike conductors, with the case containing the negative charge and the rod the positive.

A good flashlight battery has an electrical charge of  $1\frac{1}{2}$  volts. As the battery is used, the voltage gets lower. Finally, it reaches a point where it no longer furnishes enough electrical power to do the job right and must be replaced. The battery is then said to be discharged or run-down.

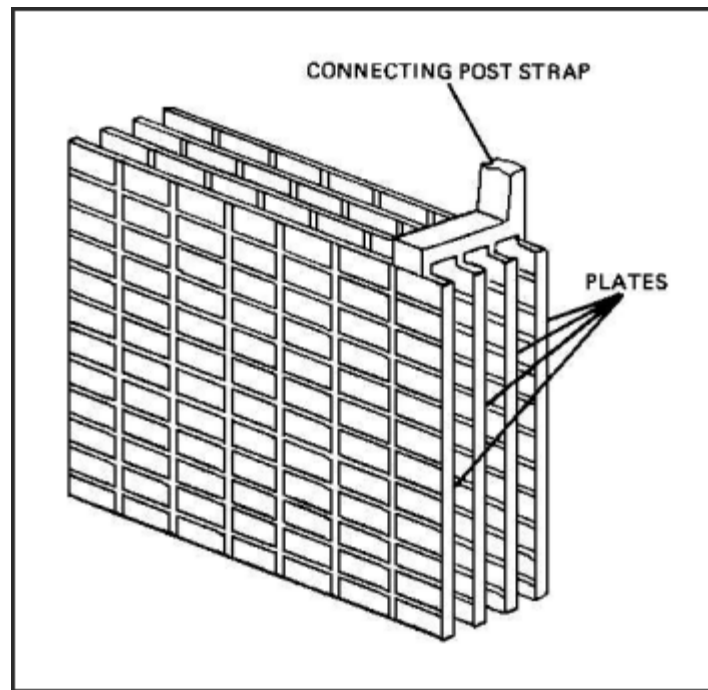
## CONSTRUCTION

Storage batteries used in automotive vehicles are the lead-acid type and are often referred to as wet-cell batteries. They operate on the same principle as our lemon battery and the flashlight battery, using an electrolyte and two unlike conductors to store electrical energy in chemical form. To satisfy the high current and dependability requirements of automotive vehicles, the construction of the lead-acid storage battery is complex. The parts of the battery are described below.



**FIGURE 15. PLATE CONSTRUCTION.**

The conductors that are immersed in electrolyte are two kinds of PLATES known as positive and negative plates. Both the positive and negative plates have a grid framework made of a stiff lead alloy for strength. The active material is applied to the grids in paste form and allowed to dry and harden like cement, then it is put through a special forming process. When finished, the active material of the positive plates is brown lead peroxide, the negative plates, gray spongy lead.



**FIGURE 16. CELL GROUP CONSTRUCTION.**

Each plate has a lug on one top corner. Several plates are combined into positive and negative GROUPS by welding these lugs to a plate strap, which is also made of lead. A negative group of plates has negative plates only and a positive group positive plates only. The plate strap on each group of plates contains a terminal post, which forms an outside electrical connection.

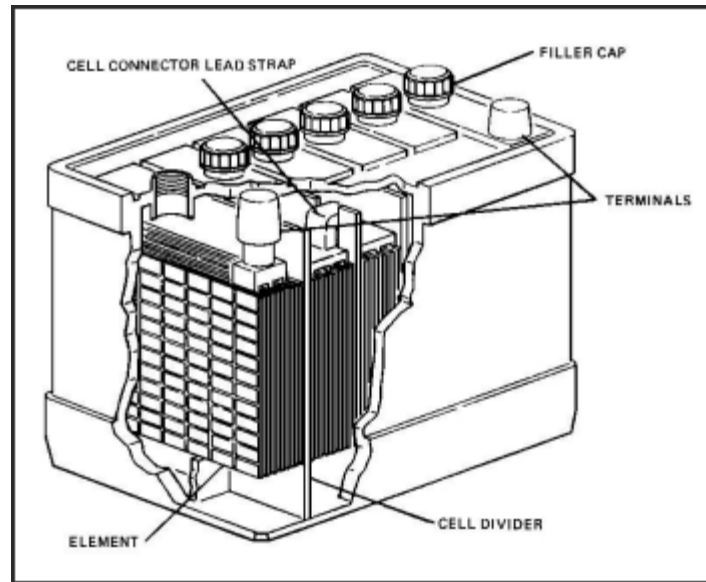
A positive and a negative plate group, along with several insulators called SEPARATORS, are put together to form an ELEMENT. The thin separators are inserted between the positive and negative plates to prevent them from touching and short-circuiting the battery internally. They are generally made of a material, such as wood, rubber, or glass, and contain many small holes so the liquid electrolyte can pass through.



When the assembled element, consisting of the positive and negative plate groups and separators, is immersed in electrolyte, it becomes a CELL. The voltage of a charged cell as measured with an open circuit is about 2.1 volts, regardless of the size of the cell. For practical purposes we generally just say that the voltage of the cell is 2 volts. In order to obtain more than 2 volts from a battery, several cells are used and connected in series (negative to positive). For example, a 6-volt battery will contain three cells and a 12-volt battery six cells. The cell terminals are connected by welding them to connector straps.

All the cells of a battery are placed in a one-piece container or case that is divided into compartments. Each compartment is the container for one cell. The bottom of each cell compartment generally has raised ribs for the element to rest on. The area between the ribs serves as sediment space. During use, the active material on the plates gradually sheds and falls into the sediment space. The entire container is made of hard rubber or some other insulating material that is resistant to acid and to mechanical shock.

## Lesson 2/Learning Event 1



**FIGURE 17. CROSS-SECTION OF A TYPICAL STORAGE BATTERY.**

The top of each cell is fitted with a cell cover made from a material, such as hard rubber like the container. Some cell covers are made so the straps connecting the cell terminals are exposed. On others, the connecting straps are covered and only two terminal posts are exposed. Regardless of the type of cover used, each cell cover is fitted with a vent plug, which may be removed to inspect the cell or to add water.

To seal the battery after the cell cover is installed, the space between the edges of the cell covers and the container is filled with an acid-resistant compound. Some form of seal is also used where the terminal post extends through the cover.

The vent plug (filler cap) contains a small hole to permit the escape of gas formed in the cell. A series of baffles may be built into the plug so the gas must pass around them in leaving the cell. The baffles prevent electrolyte from splashing out through the venthole. Also, any mist from the electrolyte is collected here and returned to the cell.

Batteries designed for use in tactical vehicles are waterproof. The vent plugs will not allow water to enter the cells during fording operations but will still permit gases to escape. This is done by a pressure vent valve in the vent plug. The valve closes to external water pressure and opens to release internal gas pressure.

Electrical power comes from the battery through two TERMINAL POSTS. The posts are tapered, and the positive terminal is slightly larger than the negative terminal. The cable clamps are also made in two sizes, to reduce the chances of connecting a battery in reverse.

The cells of the battery are filled with a mixture of sulfuric acid and distilled water, the electrolyte. Electrical energy is produced by the chemical action of the sulfuric acid on the plates. The electrolyte also serves as a carrier for the electric current inside the battery. The electrolyte of a fully charged battery contains about 38 percent sulfuric acid by weight (about 27 percent by volume).

OPERATION

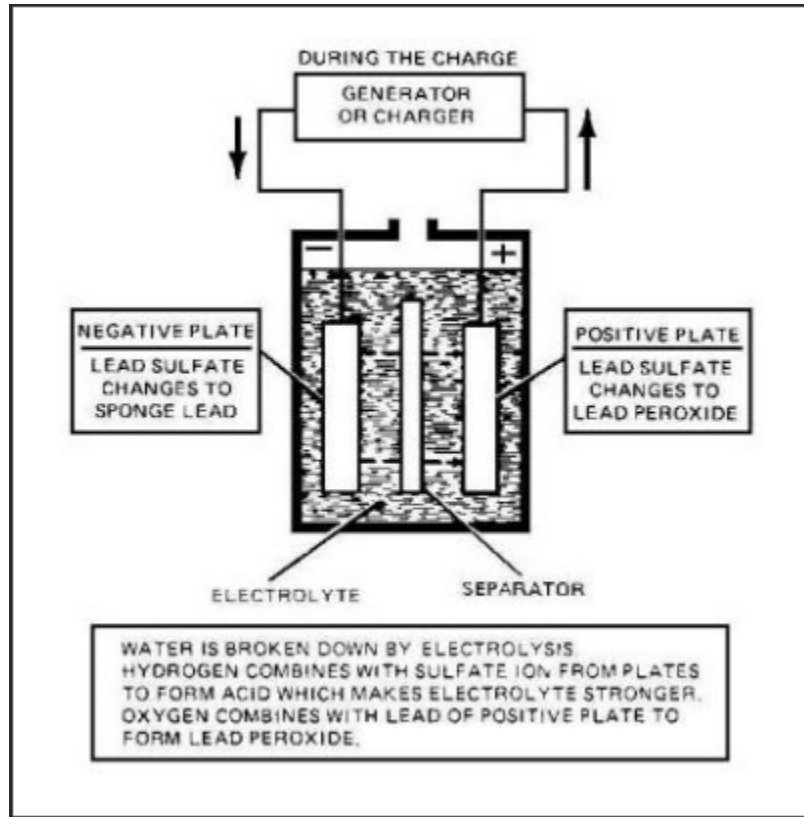


FIGURE 18. BATTERY DISCHARGE/CHARGE CYCLE.

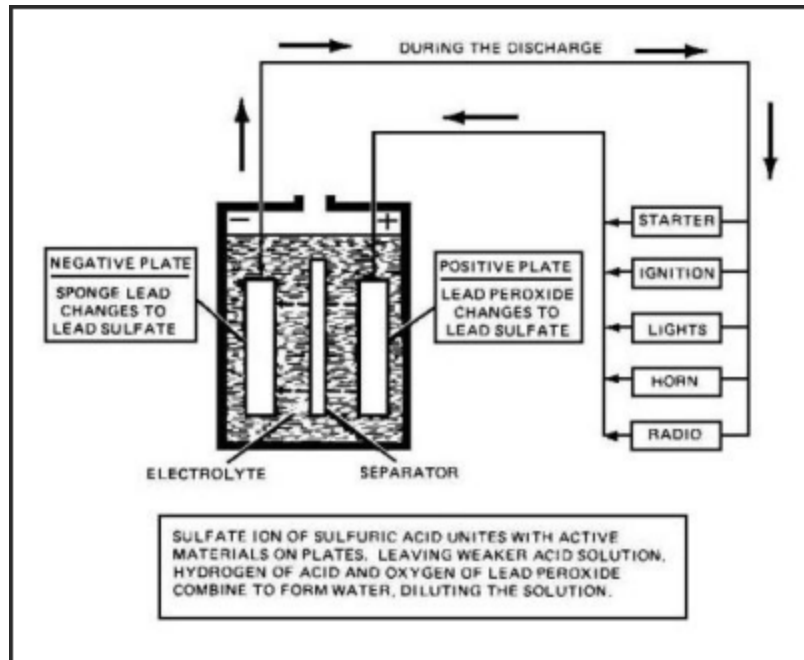


FIGURE 18. BATTERY DISCHARGE/CHARGE CYCLE (CONTINUED).

## Lesson 2/Learning Event 1

Now that you are familiar with the construction of the automotive battery, let's consider the chemical reaction that takes place in the battery.

A battery cell is said to be fully charged when the electrolyte is full strength. The active material of the negative plates consists of spongy lead, and the active material of the positive plates consists of lead peroxide.

When a load is connected to the battery, electrons flow from the negative plates to the positive plates. The battery is said to be "discharging." Chemical changes take place inside the battery during discharging:

- As the current flows, atoms of the sulfuric acid leave the electrolyte and enter the battery plates. This decreases the amount of acid that is in the electrolyte, making the mixture weaker.
- As you recall, atoms from all elements are different, and the nature of all materials is determined by the atoms they contain. Therefore, the atoms of sulfuric acid mixing with the battery plates will change the nature of the plates. The spongy lead of the negative plates turns into lead sulfate; the lead peroxide of the positive plates also turns into lead sulfate.

If current flow continues, the electrolyte will get weaker and weaker until it is almost all water. At the same time, the negative and positive plates will be gradually turning into lead sulfate so that they are becoming alike (both lead sulfate). Finally, the battery reaches a point where it will no longer supply enough voltage to cause the current flow, and the battery is then said to be discharged.

This chemical reaction in the automotive battery can be reversed and the discharged battery returned to a charged state. This is done by supplying DC from an external power source, such as a DC generator, and running it through the battery opposite the direction it travels when the battery is discharging. This causes the atoms from the acid to return to the electrolyte making the electrolyte stronger. As the acid atoms leave the battery plates, the plates change back to their original nature--spongy lead and lead peroxide.

- As a battery is charged, some of the water in the electrolyte is broken down and passes off in the form of gas. If charging is continued after the battery is fully charged, the amount of gas given off increases and the battery overheats. This is called overcharging and can damage the battery. The gas given off by a battery during the charging process is explosive and can be easily ignited by a spark.
- Repeated charging and discharging slowly wears out the battery. It causes the lead peroxide to fall off the positive plates into the sediment space in the bottom of the container. The sediment may build up high enough to cause a short circuit between the negative and positive plates, but normally the cell will be worn out before the sediment reaches the bottom of the plates.

### **SPECIFIC GRAVITY**

The strength of the battery electrolyte is determined by comparing its weight to that of an equal volume of pure water. Pure water has a specific gravity (weight) of 1.000. Let's suppose that we compare 1 gallon of water to 1 gallon of a second substance and find that the second substance weighs  $2\frac{1}{2}$  times more than the water. The second substance is said to have a specific gravity of 2.500 or  $2\frac{1}{2}$  times that of water. Pure sulfuric acid has a specific gravity of 1.835.

Since electrolyte is a mixture of sulfuric acid and water, the specific gravity of electrolyte will be more than the 1.000 of the water but less than the 1.835 of the acid. The mixture that is generally placed in batteries has a specific gravity of 1.280, and by volume it contains 73-percent water and 27-percent sulfuric acid.

Often the specific gravity of the electrolyte is simply referred to as the gravity of the battery. Also, it is customary to omit the decimal point and refer to a specific gravity of 1.280 as "twelve eighty," 1.200 as "twelve hundred," and so forth. Variations of gravity in the third decimal place are referred to as points. For example, 1.284 is four points higher than 1.280.

## Lesson 2/Learning Event 1

### VOLTAGE AND CAPACITY

There is a distinct difference between the voltage and capacity of a battery.

This difference can be easily seen by picturing two cans of water, one small and the other large, placed on top of a building. If the water from both cans is poured over the side of the building, the pressure or force it has when it hits the ground will depend on the distance it falls. The distance is the same regardless of which can the water comes from. This is comparable to battery voltage since voltage is electrical pressure. Each cell of an automotive battery has slightly over 2 volts. This is true regardless of the size of the cell.

Now, let's imagine that one of the cans contains one gallon of water and the other can five gallons. You can see that if the water is poured from both cans at the same rate, water can be poured five times as long from the large can. From another viewpoint, if we empty both cans in the same length of time, the large can pours five times as much water in the same amount of time. This is comparable to battery capacity. More battery capacity is obtained by giving the electrolyte more plate surface to contact. This can be done by making the plates larger or by using a larger number of plates.

Battery voltage and capacity are different, and each one has a definite effect upon the other as well as the circuit.

We know that the battery must supply the correct amount of voltage to push just the right amount of current through the circuits. Too much voltage will cause too much current to flow, which will burn out bulbs, and so forth. If battery voltage is too low, the current flow will not be enough and the circuits will not operate right.

When a load is connected to the battery, the current flow will cause the battery voltage to drop due to internal resistance in the battery cells. The amount of voltage drop under a load is affected by the following:

- The larger the capacity of the battery, the less the voltage drops.
- As the battery's state of charge gets lower, the more the voltage drops.
- The greater the current flow, the greater the voltage drop.



- As the battery wears out, active material drops off the plates, which reduces the battery's capacity and causes a larger voltage drop under the load.
- As outdoor temperature drops, the electrolyte gets thicker, which slows down its action and causes a larger voltage drop during cold weather.

## BATTERY RATINGS

The current required by the electrical systems of two vehicles are often different, even though they require the same voltage. For instance, both the ¼- and 5-ton trucks have 24-volt electrical systems, but the batteries used in the ¼-ton truck will not supply enough current to satisfactorily crank the large engine of the 5-ton truck.

We can tell which battery has a larger capacity or current-producing capability by physical size, just like judging a bigger can will hold more water, but that is not an exact measurement.

The amount of water the cans will hold is measured in pints, quarts, or gallons. Battery capacity is measured in ampere-hours, which is the number of amperes the battery will deliver multiplied by the number of hours the battery will deliver it. For example, suppose a battery will deliver 5 amperes for 20 hours, then 5 amperes multiplied by 20 hours equals 100 ampere-hours.

If the ampere-hour rating is based on nothing more than the method described above, the rating would change if the rate of discharge changed. Suppose that we increase the load on the battery from 5 to 10 amperes. The battery would produce the 10 amperes for a period less than 20 hours, so its rating would be less than 100 ampere-hours. As you can see, some standard procedure must be used to rate the ampere-hours so that the ratings will mean the same in all cases.

The capacity of automotive batteries is rated by a standard procedure known as the 20-hour rating. This rating gives the number of ampere-hours a battery will deliver if it is discharged at a uniform rate for 20 hours, at a temperature of 80°, and with a battery voltage of 1.75 volts per cell at the end of the 20-hour period.

Two sizes of batteries, type 2HN and 6TN, are commonly used in tactical wheeled vehicles. Both types are 12-volt batteries. The smaller 2HN battery is rated 45 ampere-hours; the larger 6TN battery is rated 100 ampere-hours.

## **Lesson 2/Learning Event 1**

### **TESTING AUTOMOTIVE BATTERIES**

Through use and age, the capacity of a battery decreases. This is due to some of the active material dropping off the plates and the build-up of a hard coating of sulfate on the plates. Because of this, testing the gravity of the battery with a hydrometer may not always reveal the true condition of the battery. The electrolyte may be strong enough, but the battery capacity may be reduced to a point where the available current supply is too small. This condition can be detected by making a high-rate discharge test of the battery.

Do not perform a high-rate discharge test when the specific gravity of the electrolyte is 1.225 or less or if the variation of specific gravity between cells is more than 25 points. After charging, the battery should be allowed to sit for several hours before a high-rate discharge test.

High-rate discharge testing instruments vary a great deal. Always perform a high-rate discharge test according to instructions for the test instrument you are using. In use, the test instrument draws a high current from the battery and the battery voltage is read on a voltmeter during the discharge. The correct amount of voltage will vary depending on the test instrument used.

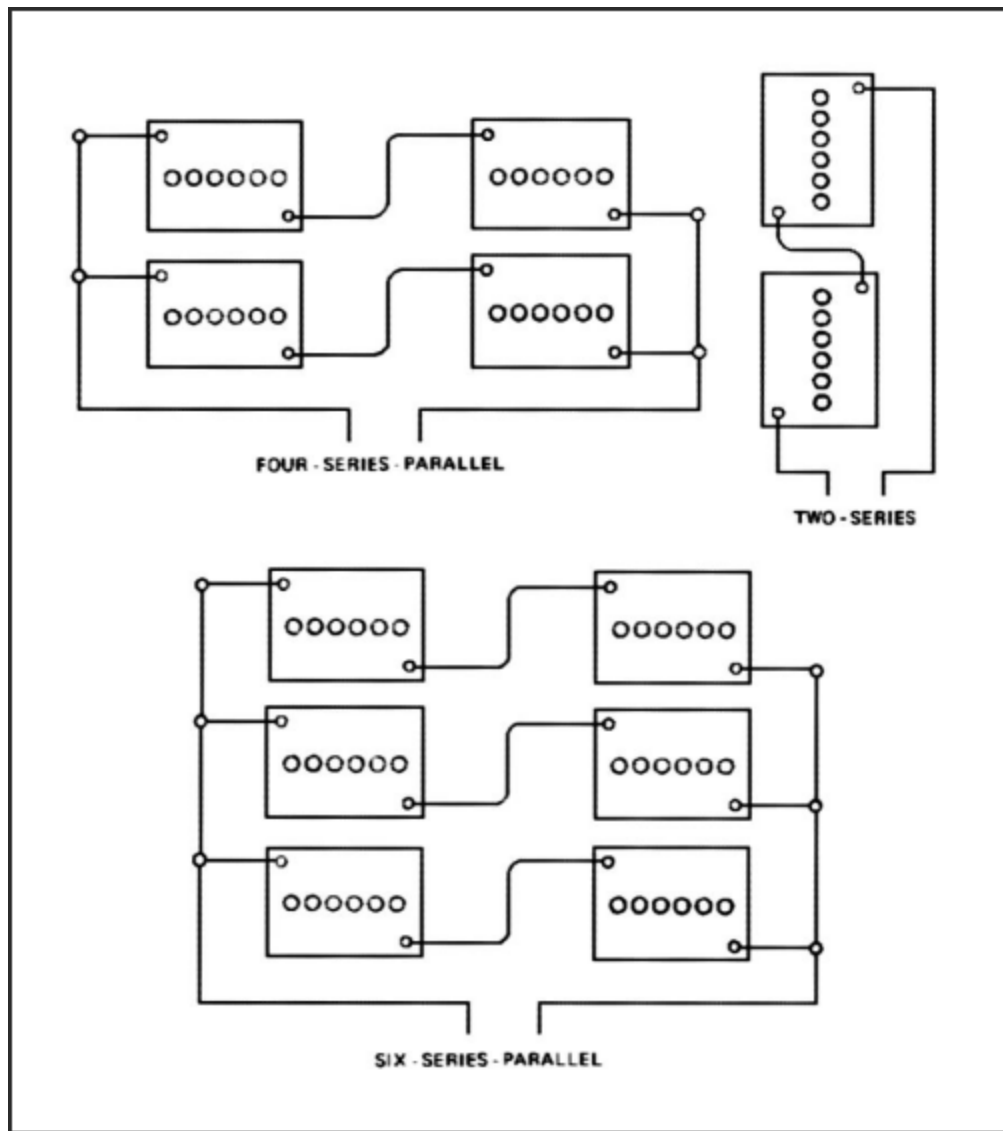
If a high-rate discharge tester is not available, batteries can still be tested if they are installed in the vehicle. This is done by using an ordinary voltmeter to measure the battery voltage while cranking the engine. The starter motor serves as the high-current load. Refer to -20 technical manual for the vehicle for the exact procedures and correct voltage readings.

### **CONNECTING BATTERIES IN SERIES AND SERIES-PARALLEL**

As you know, tactical vehicles have 24-volt electrical systems, twice the voltage supplied by each 12-volt battery used. In addition, some of the vehicles demand more current for cranking than the 100 ampere-hour battery can supply. To satisfy the increased voltage and current requirements, more than one battery is used in each vehicle. To satisfy the specific requirements of different vehicles, the batteries are connected in series or series-parallel.

In order to increase voltage, the batteries are connected in series. Recall that in a series circuit the current has only one path to follow; therefore, the same current will flow through all batteries when they are connected in series. A series connection of two batteries is made by connecting the negative terminal post of one battery to the positive terminal post of another battery. Batteries connected in series should have the same ampere-hour rating. A voltage source equal to the sum of both batteries is then available at the two remaining terminal posts. The ampere-hour rating of batteries connected in series is the same as the smallest battery by itself. For instance, some trucks use two 6TN batteries which are rated at 12 volts and 100 ampere-hours each. The batteries are connected in series to furnish a power source of 24 volts and 100 ampere-hours.

In order to increase the ampere-hour rating, the batteries are connected in parallel. In a parallel circuit the current has more than one path to follow. Batteries connected in parallel must have the same voltage rating. To connect two batteries in this manner, the positive terminal posts of both batteries are connected together and then the negative terminals of the batteries are connected. Each battery will now furnish half the current flowing in the load so their ampere-hour ratings will be added together, but the voltage will be the same as one battery alone. The parallel connection of batteries when used in tactical wheeled vehicles is combined with the series connection and is known as the series-parallel connection.



**FIGURE 19. BATTERY INSTALLATION CONFIGURATIONS.**

Batteries are connected in series-parallel to increase both the voltage and the ampere-hour rating. To demonstrate how we make use of the series-parallel connection, let's say that we have a vehicle that requires a 24-volt, 200-ampere-hour power source.

## Lesson 2/Learning Event 1

We will use four 12-volt, 100-ampere-hour batteries. The batteries are first set apart in pairs. In each pair, the batteries are connected in series so they will provide 24 volts and 100 ampere-hours per pair. Then, the two pairs are connected in parallel to increase the capacity rating to 200 ampere-hours.

## **Lesson 2/Learning Event 2**

### **Learning Event 2:**

### **DESCRIBE MAINTENANCE PROCEDURES FOR AUTOMOTIVE BATTERIES**

#### **PREVENTIVE MAINTENANCE**

In nearly all cases of early failure of automotive batteries, the cause can be traced to a lack of preventive maintenance. When given proper care, batteries generally will give no trouble until they are worn out, unless damaged by accident or enemy action. The vehicle operator and the organizational level mechanic are responsible for performing preventive maintenance on the batteries of vehicles assigned to the unit.

Each time the vehicle is started and often during its operation, the driver should check the battery-generator indicator located on the dash panel. The battery-generator indicator on tactical vehicles is a meter that shows the level of battery voltage. It has a scale marked off in three colors: red, yellow or amber, and green.

When the ignition switch is first turned on, the indicator hand will usually point to the yellow section, which is the center part of the scale. If the hand points to the red at the left side of the scale, the battery is in a low state of charge. (The hand may point to the green scale on the right if the battery was just recently charged at a high rate.)

If the battery charge is low, find out the cause and make necessary corrections. If a battery is allowed to remain in a low state of charge for very long, the sulfate formed in the plates will harden, and it will be impossible or very difficult to return the battery to a fully charged condition.

When the engine is started, the battery-generator indicator hand will move to the right if the charging system is operating properly. The hand will point to the left half of the green part of the scale when the battery is fully charged.

If the hand moves into the right half of the green scale, the battery is being overcharged. (On some indicators this part of the scale is red instead of green.) The operator should have the charging system checked immediately before the battery or charging system is damaged. Overcharging overheats the battery, causing it to lose water at a fast rate, and can warp the plates causing permanent damage.

If the vehicle is equipped with an ammeter instead of a battery-generator indicator, the operator should check the position of the ammeter hand often during operation. For a fully charged battery, the ammeter should show a high rate of charge immediately after the vehicle is started. After about 15 minutes of operation, the charge rate should drop to about 5 amperes. When the battery is partly discharged before starting, the high-charge rate will continue for a longer period. If the ammeter does not register a charge or if the high-charge rate continues, the charging circuit should be checked immediately.

After operation, check the battery to see that it is clean, securely mounted, and not leaking. Cable terminals should be clean and secure on the battery posts. All vent caps should be present and tight.

The batteries should be thoroughly inspected and serviced once a week by doing the procedures explained below. Either the operator or the mechanic may be called upon to perform these procedures.

- Inspect the tops of the batteries very carefully and clean them if needed. They must be kept clean to prevent them from discharging through collected dirt, and so forth. To clean, tighten the vent plugs and wash the batteries with a brush dipped in an alkaline solution, such as a mixture of bicarbonate of soda (baking soda) and water. Foaming will occur due to the reaction between the cleaning solution and battery electrolyte. After the foaming stops, rinse off the batteries with clean water and wipe dry with a clean cloth.
- Inspect the battery terminals to see that they are clean and the cable clamps are tight and free of corrosion. If they are corroded, remove the cable clamps and clean the clamps and the battery posts with a solution as described above. Then, reconnect and tighten the cable clamps. Coat the terminals with a light coat of general-purpose grease to fight off corrosion. Dirt will collect on the grease, but it can be removed each time the batteries are cleaned and the terminals recoated with grease. When disconnecting the battery cables, always disconnect the ground cable first to prevent a short circuit. When connecting the cables, connect the ground cable last.

## Lesson 2/Learning Event 2

- Remove and inspect the vent plugs to see that the ventholes are open. Use a short length of stiff wire to run through the ventholes to make sure they are not plugged, but be careful not to damage the check valves in vent plugs on waterproof batteries.
- Inspect the electrolyte level and add water if it is low. Filling instructions are located on the vent plugs or the cell covers. When correct, the electrolyte level will be at least 3/8 inch above the plates. Distilled water should be used to fill batteries if it is available; if it is not available, the second choice is rainwater.
- Do not store battery water in metal containers. Minerals in water from streams or wells, or from water stored in metal, can damage and shorten the life of a battery. Water that is used for drinking can be used, but only when distilled water or rainwater is not available. A battery will be damaged less by clean water that has some minerals than by letting the electrolyte level drop below the top of the plates.
- Check the specific gravity of each cell with an optical battery/antifreeze tester.
- Inspect the battery hold-downs to make sure that the batteries are held properly in their carriers. If a battery is loose, it may bounce around and damage the container or shake the plates loose inside the cells. On the other hand, if the hold-downs are drawn too tight, the container may crack.

### **OPTICAL BATTERY/ANTIFREEZE TESTER**

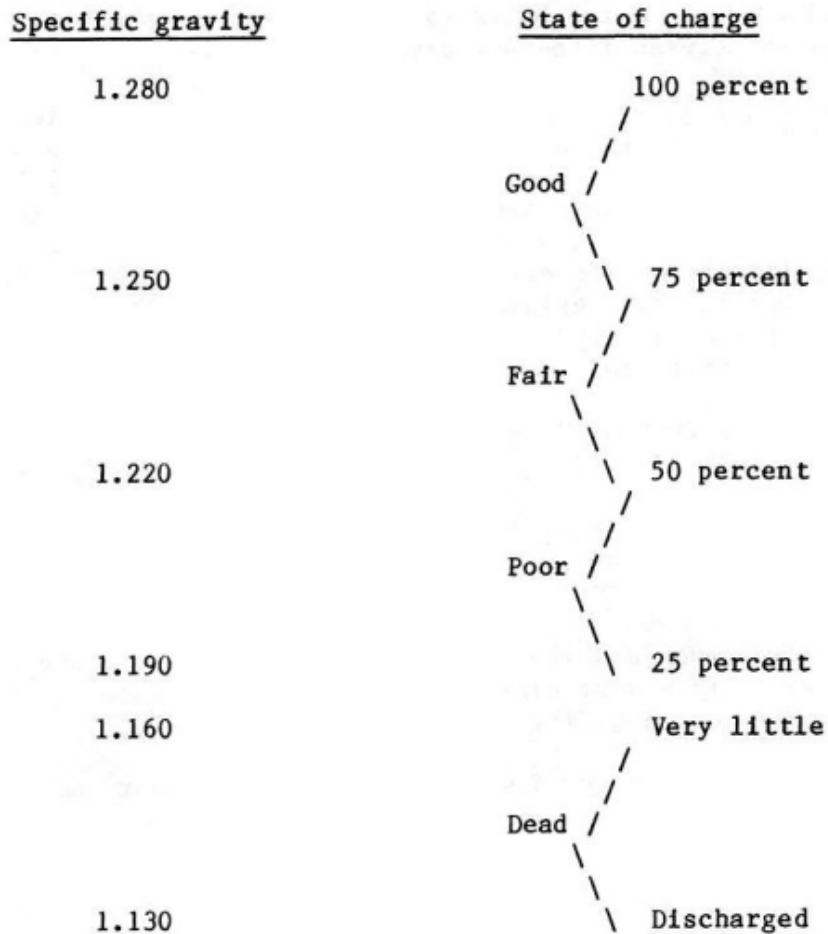
Since the amount of sulfuric acid in the electrolyte decreases as the battery discharges, the gravity of the battery also decreases as the battery's state of charge decreases. By using a tester, known as an optical battery/antifreeze tester, to measure the gravity of the electrolyte, we can tell the battery's state of charge.

The gravity of the battery is affected by temperature. When heated, the electrolyte expands so it occupies more space. When the temperature drops, the electrolyte contracts and takes up less space. Therefore, warm electrolyte weighs less than the same volume of cold electrolyte, so warm electrolyte has a lower specific gravity than cold electrolyte.



Electrolyte mixed for normal use will test 1.280 at 80°F temperature. (This is the temperature of the electrolyte and not the surrounding air.) At ordinary temperatures, it is not necessary to consider any variations when testing the gravity of a battery. However, any large variation above or below 80° is very important when deciding the true state of battery charge.

The state of the battery charge indicated by gravity readings is shown below.



Other factors to consider when you test the gravity of a battery are the level of the electrolyte and how well the electrolyte is mixed.

## Lesson 2/Learning Event 2

The electrolyte should be at the correct level in the cell. Water in the electrolyte evaporates; the acid does not. If the water has evaporated enough so the electrolyte level is low, the mixture will be strong and the gravity reading will be high. On the other hand, if the battery has been overfilled with water, the electrolyte will be weakened and the reading will be low.

When water is added, it will tend to remain at the top of the cell, and you should not test immediately after adding water. If water must be added before a reading, the battery should be charged for one to two hours to mix the electrolyte before the optical battery/antifreeze tester is used.

Gravity readings will not tell the true state of the electrolyte just after a battery has been discharged at a high rate (such as just after the engine has been cranked for a long time). In this case, the acid has been used up next to the plates but the electrolyte near the top of the plates is still strong. The optical battery/antifreeze tester will read a higher state of charge than actually exists. The electrolyte will show a true reading if the battery is allowed to stand unused for several hours or if it is charged for one to two hours.

### **MEASURING SPECIFIC GRAVITY WITH THE OPTICAL BATTERY/ANTIFREEZE TESTER**

This tester is quick, accurate, and reliable. There is no guesswork or arithmetic involved. The tester automatically adjusts for temperature.

The plastic cover and the measuring window must be clean and dry. Wipe clean with a soft cloth. Clean the eyepiece lens. Use clean water to clean dirty areas.

Swing the plastic cover down until it rests against the measuring window.

Make a separate test for each battery cell.

Using the black dipstick, place a few drops of electrolyte onto the exposed portion of the measuring window.

## WARNING

**Be careful not to splash electrolyte onto you or the equipment.**

Point the tester toward a bright light source. When you look through the eyepiece lens, you will see a rectangle with two calibrated scales - battery charge readings on the left scale, antifreeze readings on the right.

The electrolyte sample will divide the rectangle with an area of light and an area of shadow. You read the scale where they meet.

A full charge is 1.225 specific gravity for tropical electrolyte and 1.280 specific gravity for temperate electrolyte.

If below 1.180 specific gravity for tropical electrolyte and 1.225 specific gravity for temperate electrolyte, replace the battery with a fully charged one if you cannot charge it in the field.

## COLD WEATHER

Battery capacity is greatly reduced by low temperatures because the electrolyte thickens and is less active. In addition, the engine is harder to crank so the starter motor requires more current. To perform satisfactorily in cold weather, the battery must be kept in peak condition. So when the temperature drops, you will have to keep a closer watch on the battery.

In cold weather do not let the specific gravity drop below 1.250 if you expect the vehicles to start. When the temperature is colder than  $-20^{\circ}\text{F}$ , the vehicles should be stored inside where it is warm, if possible. If they must be parked outside, the batteries should be heated during long periods of standby; otherwise, they will not take a charge or have enough capacity for normal use.

The electrolyte is also subject to freezing; the exact freezing point depends on the specific gravity. In a fully charged battery, the electrolyte will freeze at  $-90^{\circ}\text{F}$ . As the specific gravity drops, the freezing point rises. The following table shows the freezing point for various specific gravities.

## Lesson 2/Learning Event 2

---

Specific gravity

Freezing point, degrees Fahrenheit

---

1.000	+32
1.100	+19
1.150	+ 5
1.200	-16
1.250	-62
1.280	-90

---

If the battery electrolyte does freeze, the ice forces active material from the plates and can crack plates and containers or buckle plates and break separators. If you try to charge a frozen battery, the grids expand and shed active material. Let a frozen battery thaw out in a room at normal temperature before charging. The battery may be saved if freezing has not already caused too much damage.

If water is added to a battery, it may freeze if it is not immediately mixed with the electrolyte. For this reason, do not add water in freezing temperatures unless the battery is indoors or the vehicle is operated for at least an hour after the water is added.

### **TROPICAL CLIMATES**

The high temperatures found in the tropics create special maintenance problems that you will have to adjust to if you are assigned in one of those areas.

Rapid evaporation of the water will result due to the heat, so keep a close watch on the electrolyte level. Every effort should be made to keep the battery compartment as cool as possible during and after operation. Do not obstruct ventilation holes, or the heat will damage the batteries.

At high temperatures, the acid in the electrolyte is more active, so using a weaker solution will give good results and cause less damage to the plates and separators.

Electrolyte solution used for tropical climates should have a specific gravity of 1.200 to 1.225. You will have to weaken the solution yourself. Do this by drawing electrolyte from a supply that is already mixed to 1.280 specific gravity and add battery water until the mixture has a specific gravity of 1.200 to 1.225. You will need to add about 1 quart of water to 1 gallon of electrolyte.

If the battery was in use before it was sent to the tropics, change the electrolyte in the following manner. Make sure that the battery is fully charged, so there will be no acid left in the plates. Then, remove the vent plugs and tip the battery upside down to drain all the old electrolyte. Refill the battery with electrolyte that has been weakened to 1.200 to 1.225 specific gravity.

**WARNING**

**Be careful to avoid getting any of the electrolyte on yourself or your clothes. The acid can cause painful burns and will eat holes in your clothing.**

The following table shows various specific gravities and the state of charge for batteries with weakened electrolyte for use in the tropics.

---

Specific gravity of electrolyte used in tropical climates	State of battery charge
1.200 - 1.225	Fully charged
1.180	75 percent
1.135	50 percent
1.090	25 percent
1.045	Discharged

---

When the electrolyte in a battery has been weakened, a tag showing the full charge specific gravity should be attached to the battery. These batteries should also be identified by a white dot about 1 inch in diameter painted on the top of the battery where it can be easily seen.

## Lesson 2/Learning Event 2

### SLAVING

Normally, the charging system of a vehicle will keep the vehicle's batteries charged. Occasionally, due to excessive cranking, repeated short drives, or a fault in the electrical system, the batteries will become discharged. If the vehicle is in the field where no external method of charging is available, you will probably have to start it by towing or slaving the electrical system of another vehicle.

To slave a vehicle with discharged batteries, you must use heavy-duty jumper cables and connect its dead batteries to the good batteries of a second vehicle. Stay alert when connecting the jumper cables. The hookup must always be positive to positive and negative to negative. If either of the vehicles has an AC charging system, the rectifier will be burned out if you even momentarily touch the cables to the wrong terminals.

Never try to slave one vehicle from another one that has a power source with a smaller ampere-hour capacity rating. In other words, do not slave a 10-ton tractor with four 6TN 100 ampere-hour batteries from a ¼-ton truck with two 2HN 45 ampere-hour batteries. This will only lead to more trouble.

After connecting the jumper cables, run the live vehicle with good batteries at 1,800 revolutions per minute (RPM) for a short while. This allows its charging system to put a slight charge in the discharged batteries which helps a lot when you attempt to crank the dead vehicle. While cranking the dead vehicle, keep the live one running at 1,800 RPM so you can use the power created by its generator.

Remember that batteries will be damaged if left in a discharged state for long. After you get the slaved vehicle started, make sure the vehicle is kept in operation long enough to fully recharge its batteries. If this is not possible, arrange for the batteries to be charged from an external source. If some defect caused the batteries to discharge, get that defect corrected immediately.

Some vehicles are equipped with slave receptacles so a slave (jumper) cable can be easily plugged in. Both vehicles involved must be equipped with these receptacles. A special two-conductor slave cable that fits the receptacles is provided. The proper positive-to-positive and negative-to-negative connection for slaving is made by merely plugging the one-piece slave cable into the slave receptacles of the two vehicles.

## CHARGING METHODS

Whenever the gravity of a battery drops below 1.225 (1.135 in tropical climates), it is best to recharge it with a battery charger under controlled conditions. The two principal ways of charging are constant current and constant potential (voltage). The method you use will depend on the equipment and facilities available.

Constant-current charging is usually done only at installations where a regular battery shop is set up. Electrical power is furnished by the 110-volt current supplied by the high lines. Since the 110-volt supply is usually AC, which will not charge batteries, it must be changed to DC. This is usually done by rectifiers.

After the incoming 110-volt power has been changed to DC, it must not be connected directly to a single 12-volt battery or the battery will be ruined. A resistance must be placed in the circuit to limit the current. This can be done by connecting a number of lamps in parallel. A 110-volt, 100-watt lamp consumes about 1 ampere of current, so four bulbs will permit 4 amperes to flow. A variable resistor of the proper value can be used instead of lamps and adjusted to give the desired current.

Several batteries are generally connected in series when charging by the constant-current method, so the power that is consumed by the current-limiting resistance is reduced. When the batteries are connected, their combined voltage should never be higher than the charging voltage. Allow 2.5 volts per cell when you add up the battery voltage. All batteries in the same series should be in about the same condition. Batteries being charged by the constant-current method must be checked often, particularly in the final stages, to avoid overcharging.

Battery chargers supplied for use in the field are the constant-potential type. A charger usually consists of a DC generator powered by a gasoline engine. They are made with 7½- and 15-volt outputs or with a 15- and 28-volt output.

When using the battery charger to charge one 12-volt battery, connect its 15-volt output or load terminals to the battery terminals. Connections must be positive-to-positive and negative-to-negative. If more than one battery is to be charged from the 15-volt output, they must be connected in parallel. If you connect the batteries in series, their voltage will be higher than the charging voltage and the charger could not force current through the batteries.

## **Lesson 2/Learning Event 2**

To charge 12-volt batteries from the 28-volt output of a charger, connect two batteries in series, then connect them to the 28-volt load terminals. To charge more than two batteries, you must connect them in series-parallel. The batteries in each series group should be in about the same condition.

When a battery is first placed on a constant-potential charging system, its voltage is much lower than the charging voltage, so a high current will flow. As the battery is charged its voltage increases, but the charging voltage remains constant. This causes the current to decrease as the battery is charged and to taper off to a very slow rate. Less attention is required near the end, but care must be taken to prevent overheating the battery at first. The constant-potential battery charger is generally equipped with a variable resistor so the operator has some control over the charging rate.

### **CHARGING PROCEDURES**

Batteries should be charged only in the open air or a well-ventilated room because of the gases they expel. Before attempting to charge a battery, give it a thorough cleaning and inspection. Do not waste your time on batteries that are cracked or damaged in any way that will make them unserviceable. Place good batteries on a board or wooden rack. Never stack them on top of each other or on the ground or a concrete floor.

Check and record the specific gravity of each cell of all the batteries to be charged. Add water to bring the electrolyte to the proper level. Arrange and connect the batteries for charging. All batteries connected in one series group should have about the same specific gravity readings. Make sure all the vent plugs are secure and the vents are not plugged, then begin the charge.

Watch closely for overheating or excessive gassing for the first few minutes of charge. If either occurs, reduce the charging rate. For best results, the battery electrolyte should not exceed 110°F temperature. The battery should gas very little when it is first placed on charge, but steady gassing later on when the battery nears full charge is normal.



Check the specific gravity of the battery often while it is being charged. Just how often will depend on the rate of charge. If a charge rate of 2½ amperes for 2HN batteries or 5 amperes for 6TN batteries is being used, check the gravity hourly when the batteries near full charge. You may reduce the time between checks if the charge rate is decreased. Add water to replace any lost during the charge. A battery is fully charged when three successive readings show no further rise in specific gravity.

When the battery is charged, remove it from the charger and clean its top to remove any acid. Inspect the battery once again for any cracks that may have opened due to the charging process. Screw the vent plugs tightly in place. If the battery has handles and the paint on them is worn, apply a coat of acid-resistant black paint.

### **PLACING BATTERIES IN SERVICE**

New batteries that you receive will probably be charged and dry. If they are, you will have to fill them with electrolyte in preparing them for service. The instructions received with new batteries on how to prepare them for service should always be followed. In general, the following instructions apply:

Remove and discard the seals from the ventholes of the vent plugs. Remove the vent plugs and fill each cell with electrolyte to the proper level. The temperature of the battery must be at least 60°F. Let the battery stand for 30 minutes after filling to allow the plates and separators to become soaked, then check the specific gravity of each cell. The electrolyte level must be correct.

The battery is now ready for use unless one or more of the following conditions exist:

- The specific gravity of any cell is below 1.250 after the 30-minute stand.
- The battery will not be used for 12 hours after filling.
- The battery is going into service in temperatures below zero.

If any of the above conditions exists, the battery must be charged. If you have the time and equipment, it is always best to charge the battery regardless of the conditions to ensure longer service life. After charging, the specific gravity should be at or very near 1.280.

## **Lesson 2/Learning Event 2**

When batteries are selected for installation in a vehicle, they should be matched. This applies to both new and charged batteries. If two batteries with one weaker than the other are placed in a vehicle, the vehicle's charging system will overcharge the stronger battery in an attempt to charge the weak one. This causes overheating and loss of water in the stronger battery, shortening its life. In matching batteries, you should pair batteries that have about the same specific gravity and voltage.

**PRACTICE EXERCISE**

1. The positive and negative plates in the lead-acid battery are made mechanically strong by the use of a
  - a. separator.
  - b. grid.
  - c. paste.
  
2. What is the state of charge of a battery that reads 1.280 at 100°F?
  - a. Good
  - b. Fair
  - c. Poor
  
3. The level of the electrolyte above the battery plates should be at least
  - a. 1/8 inch.
  - b. 3/8 inch.
  - c. 3/4 inch.
  
4. In the field, you may have to start a vehicle with discharged batteries by
  - a. AC or DC current.
  - b. cleaning the terminals.
  - c. towing the vehicle or slaving the batteries.
  
5. What should be done if the battery electrolyte freezes?
  - a. Thaw at room temperature
  - b. Charge battery at a slow rate
  - c. Add acid to lower freezing point

## Lesson 2

### ANSWERS TO PRACTICE EXERCISE

1. b (page 33)
2. a (page 51)
3. b (page 50)
4. c (page 56)
5. a (page 54)

## LESSON 3

### FUNDAMENTALS OF ELECTRICAL TEST EQUIPMENT

#### TASK

Describe the purpose, construction, and operation of electrical test equipment.

#### CONDITIONS

Given information on voltmeters, ammeters, and ohmmeters; low voltage circuit testers; multimeters; and simplified test equipment for internal combustion engines (STE/ICE).

#### STANDARDS

Answer 70 percent of the multiple-choice items covering electrical test equipment.

#### REFERENCES

TM9-4910-571-12&P

TM9-8000

Applicable LVCT TM

Applicable multimeter TM

#### Learning Event 1:

#### DESCRIBE PRINCIPLES OF METERS

#### INTRODUCTION

If we did not know how to measure, where would we be? Throughout each day, we make various measurements. For example, we squeeze out the right amount of toothpaste onto the toothbrush. When we go grocery shopping, we pay according to weight or size of the products we buy. We measure time with our wristwatches and clocks.

## Lesson 3/Learning Event 1

Another example of daily measurement is the water and electricity supplied to our homes. These measurements are made with meters that measure how much you use (volume or flowmeters). Water and electricity bills are based on these meter readings. You have probably seen at least one of these meters as the electricity meter should be mounted on your house in plain view. These flowmeters, which are read by the "meter man," are only one of the many types of measuring devices needed to show service personnel how a system is operating. Both water and electricity systems work best in a certain pressure range. Both systems, therefore, include pressure-measuring devices at various points along the line.

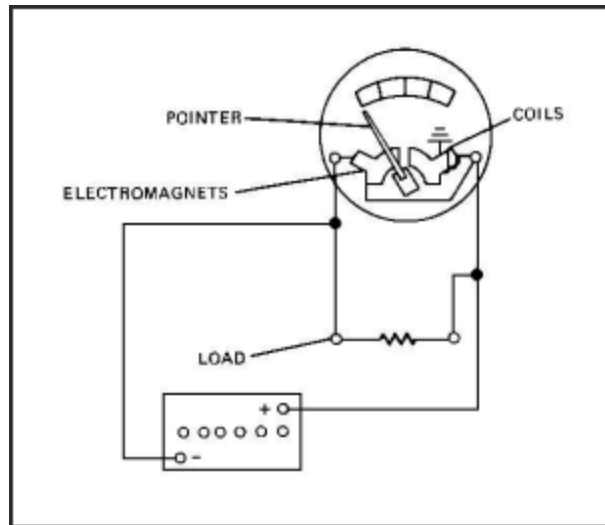
Automotive electrical systems also require various measurements to indicate how they are operating. The automotive electrical system actually resembles the water system in your home in many ways.

### **VOLTMETER**

You know that voltage is measured with a voltmeter. Let's compare the flow of voltage with a water system.

Have you ever opened the valve or spigot at your bathroom sink and the water flowed very slowly? The next time you opened the valve a few hours later the waterflow was back to normal. The problem was probably caused by a pressure loss in the water system. If you could have looked at a pressure gage on the water system, you would have found the pressure was lower than normal when the water flowed too slowly. This tells you that the pressure in a water system affects the flow. The same is true of an automotive electrical system. When the pressure (voltage) drops, it causes the flow (current) to drop also and makes electrical components work improperly. For example, electric motors run too slow, solenoids or electromagnets do not have enough strength to operate, and lights and lamps do not burn brightly.

Let's compare a simple electrical system to a simple water system and see how the voltmeter measures pressure. Notice that the electrical system, shown in Figure 20 contains a battery on the left. The battery is connected to the load on the right. The load could be any electrical component, such as a light bulb, electromagnet, or an electric motor. The current flows from the battery to the load, then through the load and back to the battery. Like the water system, the electrical pressure gage (voltmeter) must sample the pressure or voltage in this circuit.



**FIGURE 20. VOLTMETER OPERATION.**

### CAUTION

**Always remove all jewelry, such as wristwatches and rings, before you make any test on electrical equipment. These metal items could cause you to be shocked or burned.**

The voltmeter, which has two connections, is connected to the electrical circuit in the following manner. One connection is connected to the positive side of the circuit and the other is connected to the negative side of the circuit. These connections then become the positive and negative sides of the voltmeter. By connecting the voltmeter in this manner, equal voltage is applied to both the voltmeter and load. The flow of electricity or current now has two paths to follow. One path is through the load, and the other path is through the meter. The wires in the meter are very long, and small in diameter, making the resistance high. This means very little current will flow through the meter.

## Lesson 3/Learning Event 1

The resistance of the load varies depending on the type of load, such as a small lamp compared to a large motor. However, the resistance of the load is generally less than that of the meter. For this reason, most of the current in the circuit flows through the load. The two paths are side by side or parallel. We say the voltmeter is connected parallel to the circuit.

The voltmeter contains a pointer or hand known as the indicating pointer. This pointer is connected to an electromagnet. The pointer and electromagnet are mounted on a pivot or hinge pin and can be moved or swung around like a door. A very small coil spring, known as a hairspring, holds the pointer on zero when the meter is not in use. It also returns the pointer to zero when the meter is in use if the voltage stops or the meter is disconnected.

When voltage is applied to the voltmeter, it moves the current through the electromagnet. The electromagnet then forces or moves the pointer away from zero. The amount it moves depends on how much voltage is applied, because, as the voltage is increased the current will increase, and as the voltage decreases so does the current. The more pressure or voltage applied to the circuit, the more current that will flow and the voltmeter will, therefore, change as the voltage changes.

The main thing to remember is that the voltmeter is connected parallel to the main circuit. If the voltmeter was connected so that all the current within a circuit passed through the meter, it would be connected in series. If a voltmeter was accidentally connected in this manner, it would in most cases indicate the source voltage. However, the load component(s) would not operate normally due to the high resistance the voltmeter placed in the circuit. When the voltmeter is used to test a battery with no load applied, positive is connected to positive and negative is connected to negative. However, in that case the meter and the battery make up the complete circuit.

Voltmeters do not all look alike. There are many types and sizes of portable voltmeters. Large, complex electrical equipment has built-in voltmeters, because slight variations in voltage greatly affect the operation of this equipment. Operators or service personnel must constantly measure the voltage on such equipment and make quick adjustments whenever needed.



Automotive electrical systems are not as sensitive and are designed for more variation in voltage. Therefore, built-in voltmeters are not needed on vehicles. If the voltage varies more than is allowed or if the voltage is thought to be wrong, portable voltmeters are available to measure the voltage. Some voltmeters are in separate cases while others are part of a combination-type meter. Two good examples of combination meters are the low-voltage circuit tester and multimeter.

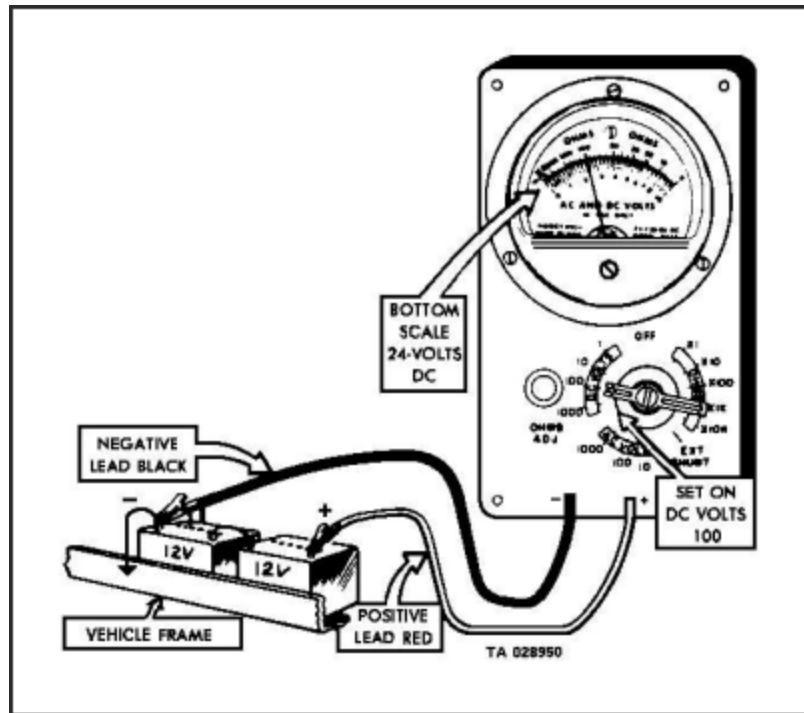
Voltmeters vary depending on their model and use. For example, some voltmeters have only one scale and others have two or more scales. All portable voltmeters include flexible test leads, lengths of wire with a male plug on the meter end and a test probe or an alligator clip on the other end. The test leads are usually color-coded red and black. The red lead is connected to the positive terminal on the meter and the positive side of the circuit to be tested. The black lead is used to connect the negative terminal of the meter to the negative side of the circuit.

There are two ways to connect the two test leads to the meter so that all ranges can be used. In one method, the test leads are always connected to the same two terminal sockets of the meter, and a selector switch is used to select the proper range. The second method uses one common terminal for the negative or positive lead, and the other lead is connected to a different terminal for each range.

Why do we need more than one range on a voltmeter? Why not have one range from 0 to 500 volts? That is not practical. Electrical test meters are most accurate in the center of the scale or range. This means the 0- to 500-volt scale would be most accurate around 250 volts. The battery-generator voltage of most military vehicles is in the 24- to 28-volt range. You will therefore be using the voltmeter to test voltages ranging from 5 volts to a fraction of 1 volt.

Suppose you were issued a voltmeter like the one in Figure 21. Do you think you could use it? Notice that the meter dial contains three ranges or scales, but the selector switch indicates there are actually four ranges. The ranges on this voltmeter are 0 to 1 volt, 0 to 10 volts, 0 to 20 volts, and 0 to 50 volts.

The range or scale for 0 to 10 volts can also be accurately used when the selector switch is in the 0- to 1-volt position. The numbers on the 0- to 10-volt scale then become tenths of a volt. For example, 2 becomes 0.2 (two tenths) of a volt, 3 becomes 0.3 volt and 10 becomes 1.0 volt.



**FIGURE 21. MEASURING DC VOLTAGE.**

Let's assume you want to test the voltage in the circuit in Figure 21, which includes a set of batteries. First, make sure the selector switch is off. Then, connect the test leads to the meter as in the figure. The red lead connects to the positive (+) terminal and the black lead to the negative (-) terminal. Next, connect the leads to the circuit to be tested. Remember, parallel or across the circuit. Connect the red lead to the positive side and the black lead to the negative side. Now you are ready to measure the voltage. Turn the selector switch to 100, and you have connected the meter to the circuit.

If the battery is charged and the load in this circuit is small, such as a small bulb, the meter should indicate close to 24 volts. Notice this is about the center of this scale. Let us say you are checking a defective 24-volt circuit with a heavy load, such as a starter. When you switch the selector to 50, the meter indicates only approximately (about 12 volts). If you want to get a more exact measurement, switch the selector to 20. You are now using the 0 to 20 scale, and it is easier to read for this particular voltage.

### CAUTION

**You must turn the selector switch back to 50 or to OFF before this heavy load is disconnected from the circuit. If you do not, the meter will be damaged if the voltage jumps past 20 volts when the load is disconnected.**

Notice that ranges for the selector switch start with the highest range 0 to 50. As the selector is turned to the right, the ranges become smaller. This prevents burnout of the meter by the operator having to go through the higher ranges first, once the operator leaves the OFF position.

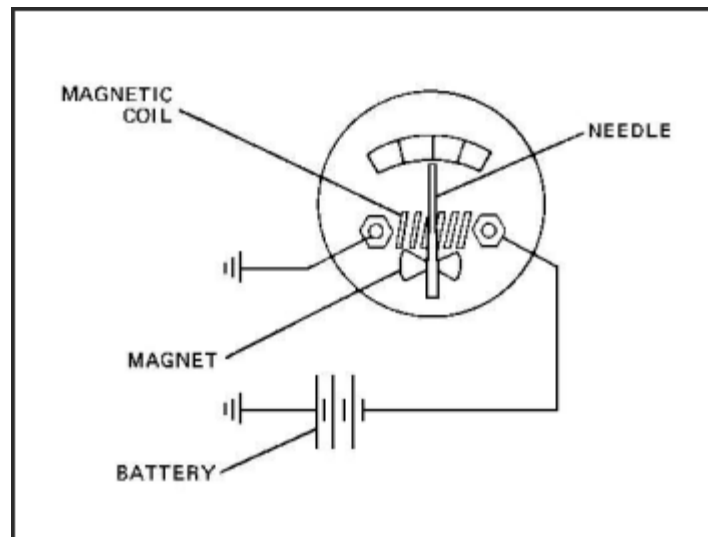
Let us review what you have learned so far. We learned the automotive electrical system is in many ways similar to a water system. We learned electrical pressure is measured with a voltmeter as water pressure is measured with a pressure gage. We have also learned how a voltmeter is connected to an electrical circuit. We know this is only one of many measurements that can be made on the automotive electrical system. Let us next see how current can be measured with an ammeter.

### AMMETERS

If we want to find out how much water is flowing through a pipe in a water system, we install a flowmeter, placed in the pipe in such a way that all of the water moving through the pipe goes through the meter. The meter "counts" (measures) the gallons of water that move through it.

The ammeter does the same thing in an electrical circuit. The ammeter measures the amount of current moving through the wire. While the flowmeter measures the water flow in gallons, the ammeter measures the electrical current in amperes. The gallon is a unit of measure for water and other liquids; the ampere is a unit of measure for electrical current. Amperes are often called "amps" or "amps of current."

## Lesson 3/Learning Event 1



**FIGURE 22. AMMETER OPERATION.**

The ammeter must be placed in the electrical circuit in such a way that all the current flows through it. It is necessary to break the circuit and connect the ammeter into it. The electrical term for this type of connection is series. A series circuit is one that has only one path or wire through which the current can flow.

An ammeter is always connected in series so it can measure the total amount of current (amperage) flowing. Figure 22 shows the right way to install an ammeter.

There are three general types of ammeters.

The first type is used in the instrument panel of some automobiles and trucks. This particular ammeter can be identified by the zero in the center of the scale and equal numbers to each side of the zero. A minus or negative symbol (-) or the word "discharge" is located at the far left of the numbers. A positive symbol (+) or the word "charge" is located to the far right of the numbers. This ammeter shows the operator whether the battery is charging or discharging.

The second type of ammeter has the zero located at the left side of the dial and numbers increasing to the right side of the dial. This ammeter is found on many battery chargers. Its purpose is to show the rate at which the battery is being charged.

The third type of ammeter is found in most automotive testing equipment. It can be identified by the zero located close to the left end of the scale and the numbers increasing on each side of the zero. The right side increases much more than the left. Let's find out how this ammeter is used.

An ammeter resembles a voltmeter in many ways. It may contain one or more scales on its face or dial. Ammeters with only one scale, like voltmeters, are limited in use. Ammeters with two or more scales generally have a terminal connection for each scale instead of a selector switch, especially if the ammeter is made to measure high amperage. Ammeters with terminal connections for each range have one common terminal. One test lead is connected to this terminal; the other is connected to the terminal of the range desired. The ammeter, like the voltmeter, may be a separate meter or a part of a test instrument that contains other test equipment.

The electrical portion of the ammeter must be constructed to handle the amperage it must test. An internal shunt or resistor is built into many ammeters to help carry the current. Some ammeters are used to test very high amperage, and these meters are made to connect an external shunt or resistor to make the tests. This is the purpose of the exterior-shunt terminals on many ammeters. When the electrical leads are connected to these terminals, the external shunt assembly is included in the meter circuit. All ammeter leads must be connected to the meter in the right polarity (red to positive, black to negative). As you now know, the circuit must be broken and the ammeter must be connected in series so that all current will pass through the ammeter or the external shunt.

An ammeter is easy to use, if you follow proper procedures:

- You should never try to connect the ammeter into a circuit under load. This will cause arcing, when the test leads are connected, which could injure you as well as damage the equipment. This is especially true if the circuit carries a heavy amperage load. The load can generally be disconnected by opening a switch.
- The ammeter should never be connected while the vehicle engine is running.

## Lesson 3/Learning Event 1

- Make sure that all switches are turned off including the master (battery) switch.
- You should always try to determine the amount of amperes or current that you are going to measure. This information can be found in the vehicle technical manual. If you are not able to find what amperage the circuit does carry, start with the highest range on the ammeter and work down. Through this method you will not damage the ammeter by using a range too small to handle the amperage. In fact, it is always best to start testing on a scale higher than you think is necessary for a particular circuit.

Let us follow the hookup of an ammeter in a circuit with a fully charged 12-volt battery, a load, and a switch to connect or disconnect the load to or from the battery. The load is a large lamp similar to the headlamps on a vehicle. The information included with this circuit indicates there should be about 10 amperes flowing when the switch is closed. The ammeter has a range from 0 to 10 amperes; however, we will use the 0- to 50-amp range just in case the flow happens to be more than 10 amperes, which could harm the meter in the 10-ampere range. We connect the red (positive) test lead to the common terminal of the meter because it is marked positive (+). The black (negative) lead is then connected to the 50-ampere terminal on the meter. We know the ammeter must be connected in series with the circuit, so we have connected the red lead to the positive side of the circuit and the black lead to the negative side of the circuit.

In a generator output rate test, the current flow will be from the generator back to the battery. To read upscale, the leads must be connected to the circuit in reverse of a load test. That would be red (positive) lead to negative, and black (negative) lead to positive. Any load on the circuit would then be indicated to the left of zero or downscale. The charging rate from the generator would be indicated upscale.

Once you are connected correctly for a load test, complete the circuit by closing the switch. Current will then flow from the battery, through the load, through the ammeter to the switch, and back to the battery. As the current passes through the ammeter, the amount of current flow will be indicated on the upscale side of the ammeter.

The amperage capacity of an ammeter depends on its construction. The ammeter used for the load test above can accept no more than 100 amperes through the meter. With an external shunt, greater amounts of current can be measured. You will learn how a shunt is used later.

From what we have covered so far, you see that the automotive electrical system can be compared with a water system. Both systems work under pressure, and the pressure can be measured. We also learned that pressure causes a flow in the system when the system is in use. This flow can also be measured. The amount of flow in each system depends on the amount of pressure and how much resistance is in the circuit or system. In the water system, the size of pipes and valves can create resistance in the system, and the waterflow changes if the pressure is increased or the resistance is decreased. The flow of electricity in a circuit also depends on several factors. One important factor is resistance.

How can we know if the resistance in a circuit is correct? One way is to measure the voltage and amperage, and if the voltage is correct but the amperage is not, you can safely assume the resistance is wrong. We can measure resistance by itself using an ohmmeter.

### **OHMMETERS**

Anything that moves meets resistance (opposition to movement). Remember what happens to the space capsule when it returns after a trip in space? It gets so hot it has to have a heat shield to keep the astronauts from being burned to death. That heat is caused by the resistance of air as the space capsule moves through it. The faster the capsule moves, the greater the resistance of the air, and resistance to motion always creates heat.

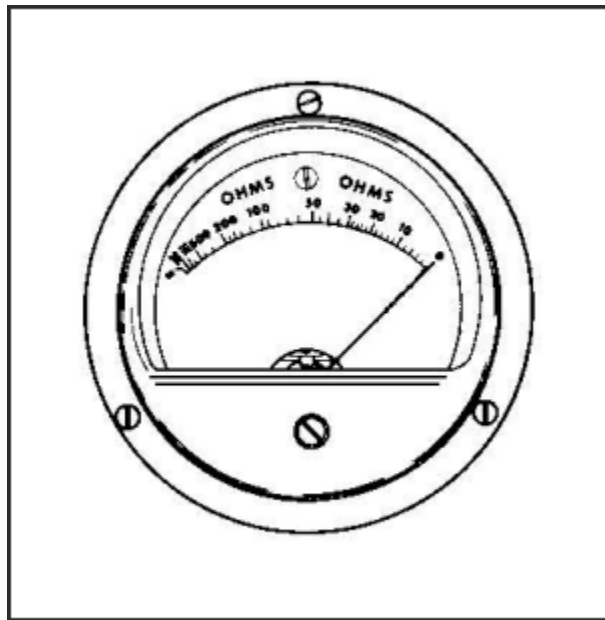
Resistance (opposition) to the movement of electricity in a wire also produces heat. Sometimes we want a lot of resistance in a wire. For example, the wires in the burners on an electric stove get red hot, and the wires in a light bulb get hot enough to shine and produce light. At other times, we want as little resistance as possible in an electrical circuit, because the resistance does cause heat and loss of voltage and reduces the amount of current that can flow.

The unit of measure for electrical resistance is the ohm. The instrument used to measure the resistance in an electrical circuit is an ohmmeter.

## Lesson 3/Learning Event 1

Many things can happen in the electrical circuit that will change the amount of resistance in the circuit. Rust or corrosion where wires are joined together will cause an increase in resistance. If the wires are not tightly joined together, there will be an increase in resistance. Wires that have been partially cut are another cause of high resistance. Whatever the cause, when the resistance in a circuit is too high, the load unit in the circuit (such as a horn, radio, headlight, or starter) will not work right--if it works at all.

The ohmmeter may be a separate meter, but more often, it is a part of a combination-type of meter known as a multimeter. Combination meters are sometimes called volt-ohm-amp meters. These meters vary in construction depending on the manufacturer. Let us find out what a simple ohmmeter looks like and how it is used.



**FIGURE 23. OHMS METER.**

Most simple ohmmeters have one scale. The scale is calibrated or has numbers from zero to infinity. The symbol for infinity looks like a figure 8 lying on its side ( $\infty$ ). Infinity means more than the meter will measure. You should notice in Figure 23 that the dial scale goes from 0 to 500 and then to 1M, 2M, and infinity. 1M means 1,000 ohms, and 2M means 2,000 ohms.



An ohmmeter is actually an ammeter that measures current flow in thousandths of an ampere. This type of ammeter is referred to as a milliammeter. Most ohmmeters consist of the milliammeter, a battery, some form of current-limiting resistance unit, and the case. In most ohmmeters, the resistance unit is actually two resistors. One is a fixed resistor and the other is a variable resistor (rheostat). The simple ohmmeter has two test leads connected to two terminals.

The ohmmeter has many uses. By measuring resistance, it locates shorted or open circuits and checks circuit continuity (zero resistance). For example, consider a wire that is broken somewhere inside a wiring harness. You can see the ends of the wire where they connect in the circuit, but the rest of the wire is hidden inside the harness. The ohmmeter can check the continuity of the wire and prove if it is broken.

Use the following procedures when beginning a test with the ohmmeter:

- Remove the ohmmeter test leads from the case and connect them to the two terminals on the ohmmeter. If the wire to be tested is in a vehicle, turn off all electricity in the vehicle's electrical system. **THIS IS IMPORTANT.** The ohmmeter has its own low-voltage battery, and the meter will be burned out if higher voltage enters it.
- The next step is to zero the ohmmeter. When the meter is not in use, the pointer or hand will be on the infinity mark. To zero the meter, touch the test lead ends together to complete a circuit. If the meter hand does not move to zero, turn the zero-ohm adjustment knob until it does. This changes the resistance of the variable resistor.
- You will find as the meter ages that you have to adjust the zero-ohm adjustment knob more and more to make up for the weaker battery. When the hand will not come back to zero with any adjustments, the battery is too weak and must be replaced.
- When the ohmmeter is zeroed, connect one lead to each end of the wire to be tested. If the wire is not broken, the tested wire will complete the circuit through the ohmmeter. The hand will move to zero. If the wire is broken, the circuit will not be completed. The hand will not move.

## Lesson 3/Learning Event 1

The ohmmeter is also valuable for testing switches. Suppose you have a small on-off switch that you think is not working, even though the lever seems to click normally. The switch has two electrical terminals. To test the switch with an ohmmeter, first zero the ohmmeter as explained above, then connect one test lead to each terminal of the switch. With the switch in the OFF position, the ohmmeter hand should not move. Then move the switch lever to the ON position. The ohmmeter hand should move to zero.

If the ohmmeter hand remained on zero in both positions, ON and OFF, what would this tell you? (Remember what makes the hand move to zero: a complete circuit through the ohmmeter and switch.) This tells you the switch is not working properly; it does not break (open) the circuit. On the other hand, if the ohmmeter indicated infinity in both ON and OFF positions, the circuit is not being closed. This means the switch is not making contact inside.

You now see how the ohmmeter can be used to locate open circuits caused by a defective switch or a broken wire.

You can also use the ohmmeter to check for shorts or an unwanted grounding effect. Let's go back to that simple on-off switch and check it to see if it is grounded. You know that the vehicle chassis acts as one wire or part of the circuit. If the switch is mounted on metal, the circuit through the switch must be insulated from the metal or the circuit will be grounded out. If the insulation fails, due to cracks, breaks, wear, and so forth, the contacts or terminals touch the metal frame and ground out. Test the switch for grounding by connecting one ohmmeter test lead to the metal frame of the switch and the other to one terminal. The ohmmeter hand should not move if the switch is not grounded. Then, change the switch position and look at the meter. Test both terminals in this manner. If the ohmmeter hand moves from infinity, the switch is grounded. You have a complete circuit or continuity from a terminal through the switch metal frame. The switch must be replaced.

So far, we have tested using infinity and zero, but how about the numbers in between these two? The numbers are used when you want to measure resistance.

As a wheeled vehicle repairer, you will not be removing or replacing many resistors; however, you will be working with many electrical components. Many of these components, functioning properly, do place resistance in an electrical circuit. Earlier in this lesson we learned these components are called the load in a circuit. If the resistance of these components is not the specified resistance, the component or the electrical circuit will not function properly. Let's see how the ohmmeter is used to measure the resistance of the load.

Let's assume we have a circuit that is fuse-protected. (Some circuits are circuit-breaker protected.) Our circuit includes a set of batteries, an electromagnet, an on-off switch, and a 3-amp fuse. For the purpose of this test, let's say the circuit blows the fuse each time a replacement fuse is installed and the switch is closed. The circuit has been checked, and the wires are not grounded. The fuse is of the right amperage (3 amperes) for the circuit. The battery voltage is normal (24 volts). The fuse will not last long enough to make an amperage load test on the circuit. The only component in this circuit that creates any measurable resistance is the load—the electromagnet. According to the wiring schematic, the electromagnet should place 12 ohms of resistance on the circuit. We will disconnect the electromagnet from the circuit and measure the electromagnet's resistance.

Do not forget to zero the ohmmeter first. Remember, the circuit to be tested is hooked up in series with the ohmmeter.

For the purpose of this test, let's say the ohmmeter hand indicates 6 ohms of resistance. This is only half of the 12 ohms the electromagnet should have. Could this difference cause the 3-ampere fuse to blow? Remember the laws you learned so far about electricity: one law states if the resistance increases in a circuit and the voltage remains the same, the current or amperage decreases.

In this case, we have the opposite of that law. The resistance decreases, the voltage remains the same, and therefore, the amperage increases. The amperage increases to more than 3 amperes, and the fuse blows, opening the circuit. This protects the circuit from an overload that would otherwise damage the wiring and components.

You now know how the ohmmeter can help you in testing circuits and switches and locating electrical system troubles. The ohmmeter you will probably use will be part of a multimeter, which is covered later in this lesson.

## **Lesson 3/Learning Event 1**

Remember, the ohmmeter is actually an ammeter and is always connected in series with a circuit. ALWAYS disconnect the vehicle battery or batteries from the circuit BEFORE connecting the ohmmeter to the circuit. You will use the ohmmeter to measure resistance, locate open circuits (broken wires), and shorts (touching wires). You can also check the operation of switches and locate grounds in a circuit.

The ohmmeter is a valuable test meter--take care of it!

So far, you have learned about the voltmeter, ammeter, and ohmmeter as separate test meters or instruments. It is more practical to combine these meters into one unit. You will be using two combined instruments: the low-voltage circuit tester and the multimeter.

**Learning Event 2:**

**DESCRIBE CONSTRUCTION AND USE OF LOW-VOLTAGE CIRCUIT TESTERS**

**INTRODUCTION**

The military low-voltage circuit tester (LVCT) is a heavy-duty test instrument. When you open the case, you will see two test meters that you are already familiar with, the ammeter and voltmeter, but there are some connections and controls not found on the separate ammeter and voltmeter. Some repairers shy away from the LVCT, but it is really simple to use. Once you learn what each connection and control is used for, the LVCT will make your troubleshooting problems a lot easier to solve.

**CONSTRUCTION**

When you are assigned to a unit that is authorized an LVCT, learn to use it as soon as possible. If your unit is issued a second LVCT that does not look anything like the first, do not send it back. The Army now uses several different models of LVCTs with only one Federal stock number (FSN). This means your unit may order an LVCT under FSN 4910-092-9136 and receive one of several different testers. All LVCTs include one ammeter and one voltmeter; however, the controls and connections vary.

The LVCT in your unit could be made by any of the following firms: Auto Test, Inc., Model 10308; Atomic Engineering, Model TV100; Austin Continental Industries, Model 1060/A; Electro Mechanisms, Inc., Model 1060; Ram Meter, Inc., Model 62F151; Allen Electric and Equipment Company, Model 30-92; or Futrenics Industries, Inc., Model 225-01. If you tried to learn each of these LVCTs from one lesson, you would be very confused. However, if you know how to use one, you easily learn how to use the others by following the instructions. Let's see what the Allen Model 30-92 LVCT looks like and how to use it.

The Allen Model 30-92 LVCT is a portable (hand carried) test instrument. It is used for testing low voltage, DC, and electrical circuits on automotive vehicles. The unit includes a voltmeter and ammeter, to measure voltage and amperage, and a load bank that is an adjustable resistance unit. The load bank is used for current tests of values up to 100 amperes on a 24-volt circuit.

COMPONENT LOCATION AND PURPOSE

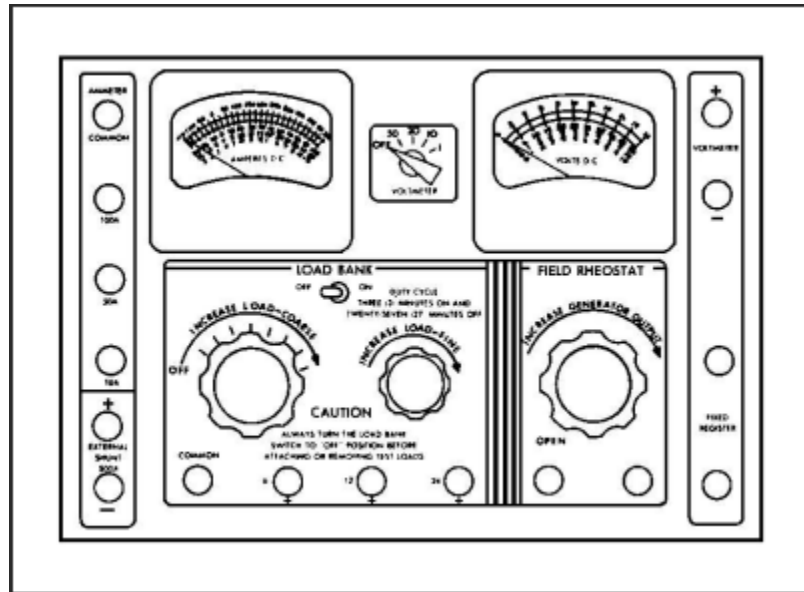


FIGURE 24. LOW VOLTAGE CIRCUIT TESTER.

The illustration shows the LVCT with the cover removed showing the various controls, meters, and connections on the face of the instrument.

Start with the ammeter. It is located on the upper left side of the tester. It has ranges from 0 to 500 amperes to the right of the zero, and from 0 to 150 amperes to the left of the zero. This range or scale is known as a "minus 150-ampere to plus 500-ampere" range. The minus figures are used to measure reverse current without reversing the meter leads.

The coarse load control is located directly below the ammeter. This is part of the load bank controls. The control has eight positions and an OFF position. During a 24-volt load operation, each position adds 12.5 amperes of load when the knob is turned to the right. If the tester is being used for a 12-volt load operation, each position from 2 to 8 adds 6.5 amperes of load. (Position 1 of the coarse load control has no control during the 12-volt load operation.) The load bank also has a fine load control located to the right of the coarse load control. This is used when you want an amperage load between the 12.5-ampere positions for 24 volts. It can also be used for the 12-volt load operation.

The field rheostat control, located in the lower right of the tester, is a variable resistor. It is used to change the generator output. This control should be left in the open position when the field rheostat is not being used.

The voltmeter in the upper right of the tester has two scales, four rows of numbers, and four ranges that can measure from 0 to 50 volts. The 0 to 10 scale is also used as an accurate 0- to 1-volt scale or range. The voltmeter has a range selector switch located to its lower left. The switch to the left of the voltmeter dial is used to turn the load bank on or off and should be left in the OFF position when not in use.

The compartment along the right-hand side of the tester is used to store test leads. There are seven separate leads and an external shunt. The leads consist of four 16-gage (light) leads (three black and one red), two 6-gage heavy leads (one black and one red), and one black jumper lead. The 16-gage leads are used to connect the voltmeter to a circuit and to connect the field rheostat to a generating circuit. The two 6-gage leads are used to connect the adjustable load bank, ammeter, and the fixed resistor to a circuit. The black jumper lead can be used anywhere it is needed in a circuit with low amperage. The external shunt consists of two large and two small leads. It is used when measuring loads from -150 amperes to +500 amperes.

The area above the ammeter and voltmeter has long slots cut in the metal. These slots allow air to circulate through the LVCT for cooling. It is very important, when the meter is in use, that they are not covered in any way.

## Lesson 3/Learning Event 2

Many terminals or connections are located around three front sides of the LVCT. We will start with the terminals to the left of the ammeter. The first two terminals are used to connect the external shunt to the LVCT. The terminals are polarity marked (+) and (-). The small red lead of the shunt is connected to the positive (+) terminal and the black lead to the negative (-) terminal.

The top of the terminal is the head of a screw. It is knurled and rough so it will not slip in your fingers. The screw is threaded into a long, smooth nut. The nut has a hole bored at right angles to the threaded screw hole, and the test lead has a long pin on the meter end, which fits into this hole. To make a connection, loosen the knurled screwhead by hand. Unscrew the knurled screw until the test lead pin will slide through the hole. Then turn the knurled screw in until it is snug on the pin. Always tighten by hand only. All of the test lead connections are connected in this manner.

Just below the external shunt connections you will see two straps. Each strap can be connected to two terminals. These straps are called links because they are a link of a circuit when they are connected. We could say they are actually a switch because they can be used to open or close a circuit. The upper link is used with the external shunt.

The next four terminals are used with the ammeter. The 6-gage test leads are connected to these terminals. Three of the terminals are marked negative (-), and each of the three matches one of the scales or ranges on the ammeter. The fourth terminal is marked COMMON and is therefore the positive (+) connection for the three ranges. For example, if you wish to measure a current flow of 20 to 30 amperes, you would connect the leads to the LVCT as follows: the red lead positive to the common terminal and the black lead to the -50A (ampere) terminal. The other ends of the leads would be connected in series with the circuit to be tested.

The next two terminals, located below the fine load control, are marked 24V and 12V respectively. These terminals are used with the COMMON terminal when placing a load on a circuit with the load bank. The 6-gage test leads are also used with these terminals, because heavy amperage (up to 100 amperes on 24-volt circuits) can be forced to flow through these terminals. The black lead is connected to the common terminal when using the load bank. The red lead is then connected to the 12- or 24-volt terminal, depending on which voltage circuit is being tested.



The next two terminals are used to connect a fixed resistor to a circuit. The resistor is located in the LVCT and is rated at 0.25 ( $\frac{1}{4}$  ohm) of resistance. It is used to test some types of voltage regulators.

The next two terminals are marked FIELD RHEOSTAT. These terminals are used to connect the adjustable resistor to a circuit. The field rheostat is used to change the strength of the electromagnet in generators, thereby changing the generator output. It can also be used to add a varied amount of resistance in other electrical circuits, if desired.

The last two connections or terminals are marked VOLTMETER. One terminal is marked positive, and the other is marked negative. These terminals are the connections for the voltmeter and are located right beside it. The 16-gage color-coded test leads (red/black) are used with these voltmeter terminals. The voltage range selector between the two meters connects the terminals to the proper range on the voltmeter.

The off-on switch between the two meters is used to turn the load bank on and off. It is always left in the OFF position except when the load bank is in use.

As you can see, it is easy to use the LVCT for simple tests. During this lesson, we discussed only one type of LVCT to help you learn what the tester is and what it is used for. Each LVCT has an instruction booklet. If you have any questions on how to use the tester, always refer to the instruction booklet.

## Lesson 3/Learning Event 3

### Learning Event 3:

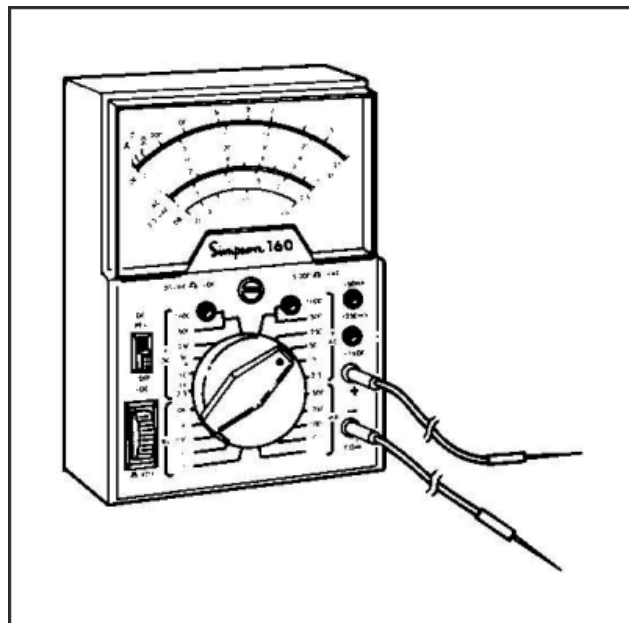
### DESCRIBE CONSTRUCTION AND USE OF MULTIMETERS

#### INTRODUCTION

You know that most ohmmeters that you will use will be part of a multimeter. The LVCT had more than one meter, but it is not a "multimeter." It measures only DC voltage and amperage and is therefore called a low voltage circuit tester. The "multimeter" measures AC and DC voltage, amperage, and resistance.

#### CONSTRUCTION

In Figure 25, the first difference you notice between the multimeter and the LVCT is the multimeter has only one dial. This dial has scales to indicate values for each of the tests the meter can make.



**FIGURE 25. MULTIMETER.**

There are several kinds of multimeters, made by different manufacturers. In general, most will have the same jacks and controls.

The jacks for various tests are usually located around the edges of the meter. There may be a common jack. This is used for the negative lead for all tests. The positive lead is placed in the appropriate jack for the test being made. In some multimeters a range selector switch is used instead of separate jacks for each range, and these meters have common positive and negative jacks.

The rheostat knob is used to zero-adjust the meter for resistance tests.

The switch knob is used to position components of the meter in the proper circuit for the test to be made.

The meter dial usually has three scales:

- One scale is for DC measurements. It can be used for either voltage or current.
- Another scale is the ohms scale. Remember, the scale is read from right to left. In other words, if there is no resistance in a circuit, the pointer will go all the way to the right or to 0 ohms. As resistance increases, the pointer will stay farther to the left.
- Another scale is for AC voltages.

You must remember that all meter scales will not be the same. You must use each meter in accordance with the way it is designed.

As you gain experience in automotive electrical system repair, you will learn the approximate resistance of each component. For example, you will learn that if the circuit is connected with light wires (18 gage or smaller) the current flow is going to be low. By dividing the approximate current flow (amperes) into the voltage, you will get some idea what the resistance should be. Always check the specifications for a system or component to get the exact amount. You should be able to find either the current or resistance for most components in the technical manual.

### Lesson 3/Learning Event 3

You can check continuity with this meter just as you did with the separate ohmmeter. Use the proper position and zero the meter before you connect it to the circuit. Like the ohmmeter, if the hand moves to zero when the leads are connected to a wire or component, there is continuity. If the hand does not move from infinity, there is no continuity—there is an open circuit or excessive resistance. If the hand stops between the infinity mark and zero, there is a readable resistance in the circuit. This resistance might be normal if there is a load-type component in the circuit. If there is no load component in the circuit, there could be a bad connection somewhere.

The continuity test will generally show this type of defect. If the continuity test on a circuit with a switch indicates resistance, the switch contacts could be dirty. This is one example of a malfunction causing resistance in a circuit. As you use the multimeter to check continuity you will learn how it will help you in locating loose connections, broken wires, dirty contacts, and other malfunctions.

When you finish using an ohmmeter, turn the range selector to any position other than a resistance position. This will prevent discharging the meter battery in case the test leads accidentally touch each other.

You can also use the multimeter to measure DC voltage. As you can see, the multimeter can be a valuable test instrument for the wheeled vehicle repairer. You can use it to locate shorts, broken circuits, and measure DC voltage as well as other tests. Remember, when you use the multimeter as an ohmmeter, make sure the circuit to be tested has no voltage in it. Turn the voltage OFF. Otherwise, the meter can be damaged beyond repair.

**Learning Event 4:**

**DESCRIBE CONSTRUCTION AND USE OF SIMPLIFIED TEST EQUIPMENT/  
INTERNAL COMBUSTION ENGINE (STE/ICE)**

**CHARACTERISTICS**

STE/ICE is a versatile tool for testing and taking measurements of vehicle engines as well as many other types of electrical and mechanical equipment. In a protective transit case, complete with all accessories, it is easily transported to a field site for general measurements and diagnostic connector assembly (DCA) tests.

**CAPABILITIES**

STE/ICE has three major measurement capabilities:

**General measurements**

STE/ICE can be used to make standard voltage, current, resistance, pressure, and speed measurements without specific vehicle or equipment information. In making general measurements, the vehicle test meter (VTM) receives power through power cable W5 or DCA cable W1. Test data may be received through various test probe cables and transducers.

**Special tests**

STE/ICE can be used to test specific vehicles in the Army inventory. When a recognized vehicle identification (VID) number is entered in the VTM, STE/ICE will automatically use vehicle information stored in its memory together with test data to give a result. In performing special tests, the VTM receives power from a battery through power cable W5 or DCA cable W1. Test data may be received through various test probe cables and transducers.

**Diagnostic connector assembly tests**

If the vehicle or equipment to be tested has a permanently mounted DCA, the VTM can receive both power and test data through DCA cable W1. Wires from the DCA connect to test points and to the vehicle/equipment or power source. Additional transducers can be used at the same time for test points not connected to the DCA.

## **Lesson 3/Learning Event 4**

### **FEATURES**

Provides summary measurements of equipment condition.

Performs a broad range of tests, quickly and accurately.

Simple to set up, operate, and interpret.

Portable.

Built-in protection against common operator errors.

Operates on 12- or 24-volt power supply.

### **VEHICLE TEST METER**

The VTM tests electrical and mechanical components. Readings are either pass/fail or digital displays (PSI, RPM, volts, and so forth).

The VTM interfaces with the vehicle or equipment being tested by either a transducer from the TK or by a DCA.

Power for the VTM is drawn from the vehicle/equipment batteries or from an alternate power source.

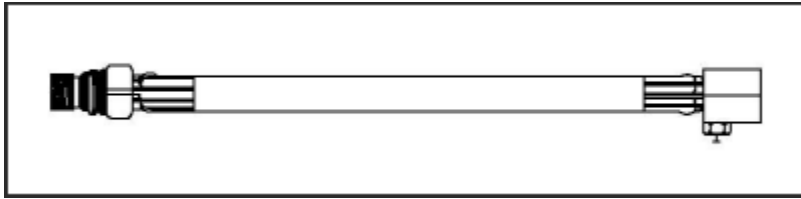
The flip cards attached to the front of the VTM provide a quick (but limited) reference for the operator. These flip cards list test numbers, messages, and some procedures. Test limits are provided for some vehicles.

### **TRANSDUCER KIT**

The transducer kit (TK) is a tray inside the transit case that contains transducers, fittings, and connectors.

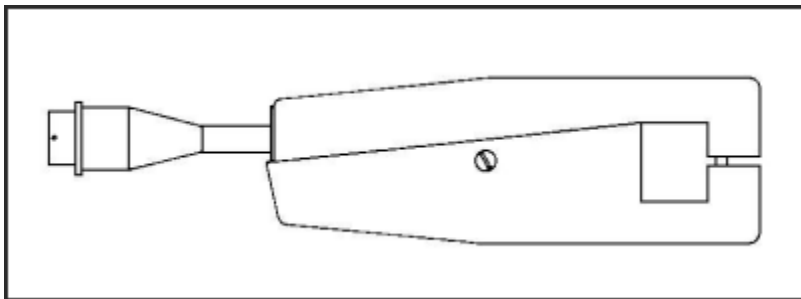
The TK is stored in a molded tray in the top of the transit case. TK item numbers shown in the illustration are for reference only and do not appear on the tray. Many of the fittings do not have part number markings on them and are referred to by TK item number and name.

**TRANSDUCERS AND FITTINGS**



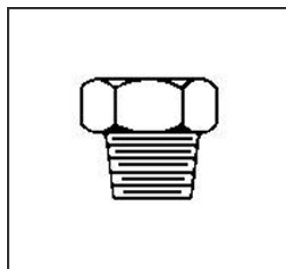
**FIGURE 26. TK ITEM 10 - HOSE AND FITTING ASSEMBLY.**

Used to measure cylinder compression pressure.



**FIGURE 27. TK ITEM 11 - CURRENT PROBE.**

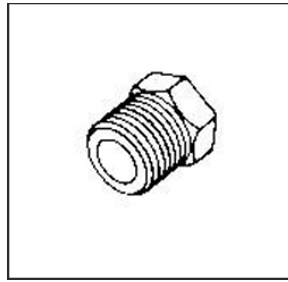
Used to measure current and frequency.



**FIGURE 28. TK ITEM 12 - 3/4- INCH REDUCER.**

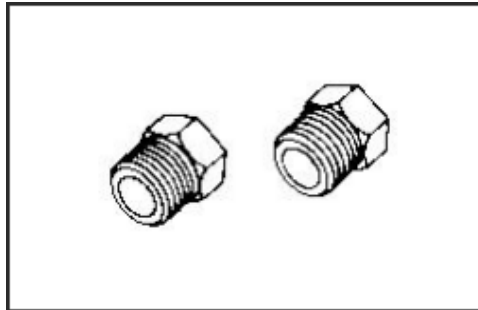
Used to reduce 3/4-inch threaded holes down to the 1/4-inch female pipe thread required for pressure transducers.

## Lesson 3/Learning Event 4



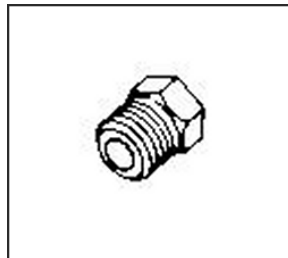
**FIGURE 29. TK ITEM 13 - 1/2- INCH REDUCER.**

Used to reduce 1/2-inch threaded holes down to the 1/4-inch female pipe thread required for pressure transducers.



**FIGURE 30. TK ITEM 14 - 3/8-INCH REDUCER (TWO).**

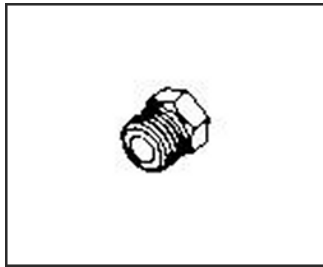
Used to reduce 3/8-inch threaded holes down to the 1/4-inch female pipe thread required for pressure transducers.



**FIGURE 31. TK ITEM 15 - 1/4- INCH PIPE PLUG.**

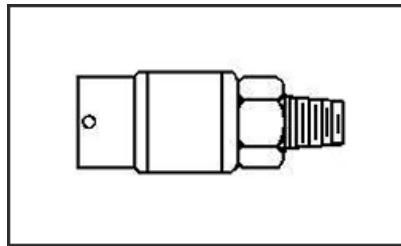
Used to plug female pipe threads of 1/4-inch pipe street tee to allow its use as an elbow or straight fitting.





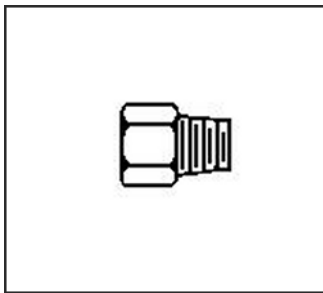
**FIGURE 32. TK ITEM 16 - 1/8-INCH PIPE PLUG.**

Used to plug female pipe threads of 1/8-inch pipe street tee to allow its use as an elbow or a straight fitting.



**FIGURE 33. TK ITEM 17 - PRESSURE TRANSDUCER.**

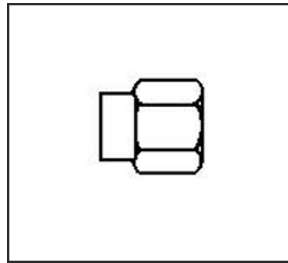
Used to measure cylinder compression, oil, fuel, and other pressures in excess of 25 PSI.



**FIGURE 34. TK ITEM 18 - 1/4- INCH MALE CONNECTOR.**

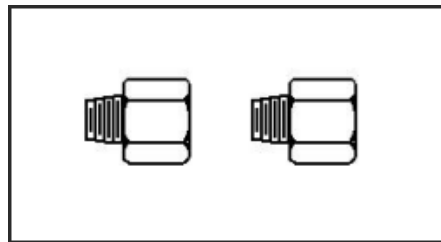
Used to connect to 5/16-inch inverted flare fitting as found on gas lines.

## Lesson 3/Learning Event 4



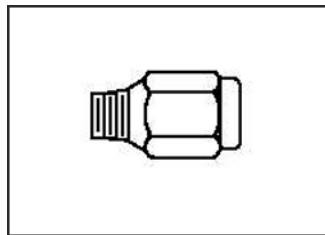
**FIGURE 35. TK ITEM 19 - PIPE REDUCER COUPLING.**

Adapts 1/8-inch male pipe thread to pressure transducer. Use with hose assembly, TK item 35, or with long hex pipe nipple, TK item 36.



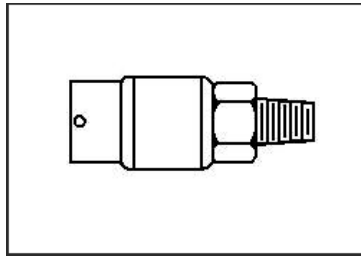
**FIGURE 36. TK ITEM 20 - ADAPTER (TWO).**

Used to adapt 1/8-inch female threaded hole to pressure transducer.



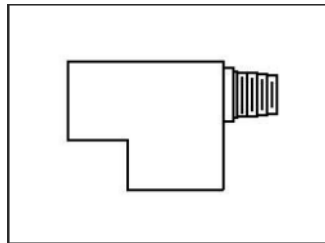
**FIGURE 37. TK ITEM 21 - SNUBBER.**

A 1/4-inch male pipe thread fitting with porous metal insert. Used with 25-PSI transducer on intake manifold of spark ignition (SI) engines. Can be used on other measurements to reduce pulsations.



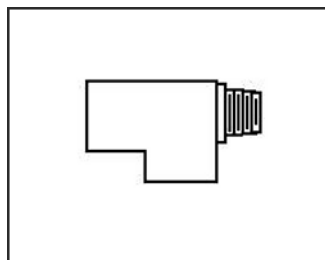
**FIGURE 38. TK ITEM 22 - PRESSURE TRANSDUCER.**

Used to measure manifold vacuum, air cleaner pressure drops, manifold pressure after turbochargers, airbox pressures, fuel pressures on SI engines, and other pressures. When measuring manifold vacuum on SI engines, use snubber, TK item 21, to protect transducer from backfiring pressures.



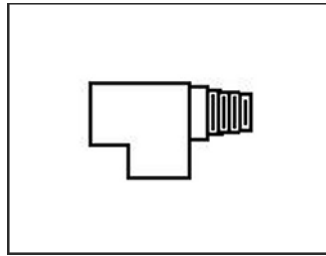
**FIGURE 39. TK ITEM 23 - 1/2- INCH STREET TEE.**

Used to tee a pressure transducer into a line where measurements are to be made under flow conditions. Use with adapters to provide thread compatibility with existing fittings.



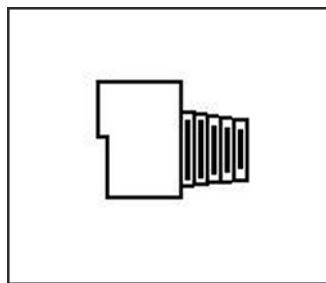
**FIGURE 40. TK ITEM 24 - 1/4- INCH STREET TEE.**

Used to tee a pressure transducer into a line where measurements are to be made under flow conditions. Use with adapters to provide thread compatibility with existing fittings.



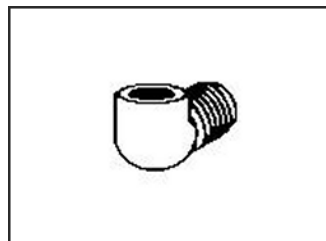
**FIGURE 41. TK ITEM 25 - 1/8-INCH STREET TEE.**

Used to tee a pressure transducer into a line where measurements are to be made under flow conditions. Use with adapters to provide thread compatibility with existing fittings.



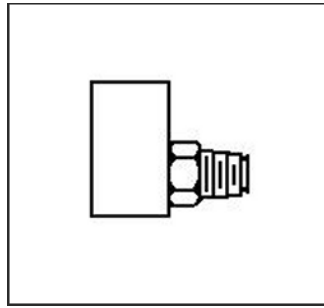
**FIGURE 42. TK ITEM 26 - 1/4- INCH STREET ELBOW.**

Used to adapt to pressure transducer in tight spaces or with other fittings.



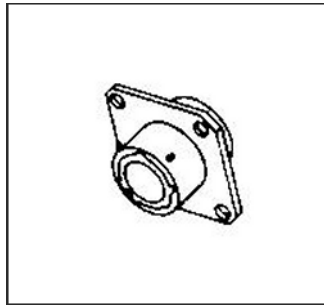
**FIGURE 43. TK ITEM 27 - 1/8-INCH STREET ELBOW.**

Used to adapt to pressure transducer in tight spaces or with other fittings.



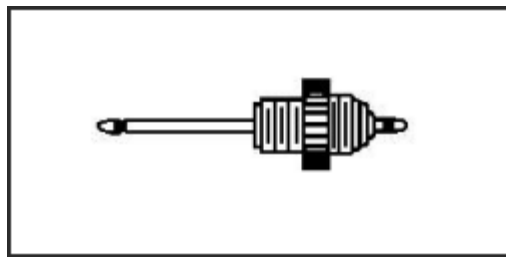
**FIGURE 44. TK ITEM 28 - INVERTED FLARE TEE.**

Used with 25 PSI pressure transducer for M880 fuel pressure measurement.



**FIGURE 45. TK ITEM 29 - ADAPTER CONNECTOR.**

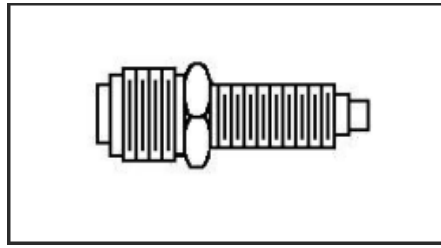
Used to connect two transducer cables together to extend reach of transducer.



**FIGURE 46. TK ITEM 30 - IGNITION ADAPTER.**

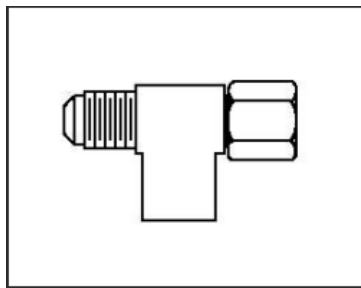
Used with ignition adapter cable for M151A2 ignition system measurements.

## Lesson 3/Learning Event 4



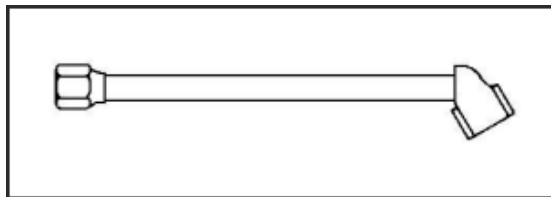
**FIGURE 47. TK ITEM 31 - TACHOMETER DRIVE ADAPTER.**

Used to adapt flexible drive shaft to pulse tachometer, TK item 34, for engine speed measurements. Attaches to instrument panel end of shaft.



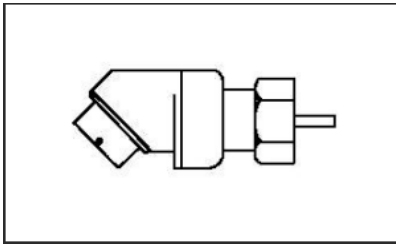
**FIGURE 48. TK ITEM 32 - FUEL LINE ADAPTER.**

Used with 1,000-PSI pressure transducer, TK item 17, to measure fuel pressure on M48A3/M60A1. Inserts in output side of fuel pump.



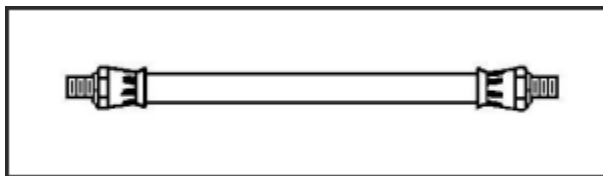
**FIGURE 49. TK ITEM 33 - AIR CHUCK.**

Used with 1,000-PSI pressure transducer, TK item 17, to measure tire pressure.



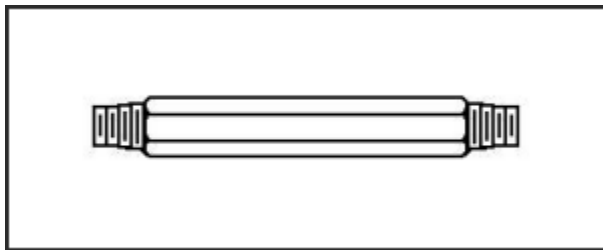
**FIGURE 50. TK ITEM 34 - PULSE TACHOMETER.**

Used to sense speed on compression ignition (CI) engines. When end of shaft is not accessible, use with tachometer drive adapter, TK item 31.



**FIGURE 51. TK ITEM 35 - FLEXIBLE HOSE ASSEMBLY.**

Used for pressure measurements on M48A3/M60 transmission and airbox measurements on Detroit diesels. Use with pipe reducer, TK item 19.



**FIGURE 52. TK ITEM 36 - LONG HEX PIPE NIPPLE.**

Used to adapt 1/8-inch pipe thread holes to pressure transducer.

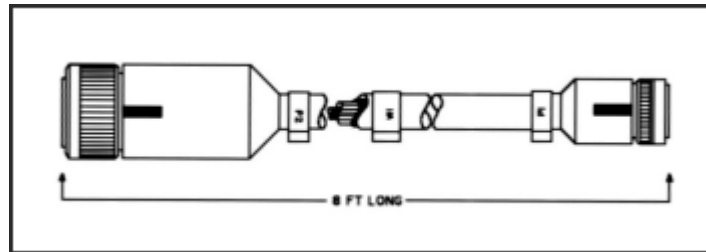
## Lesson 3/Learning Event 4

### CABLE ASSEMBLIES

Cable assemblies are included for power supply and testing and are referred to by a number for quick identification. Each cable also has a name which describes its use. W1, for example, is the DCA cable. Connectors on the cable are identified by a number preceded by either a P or an E (P1, E2, and so forth).

The cable assemblies included in the STE/ICE are:

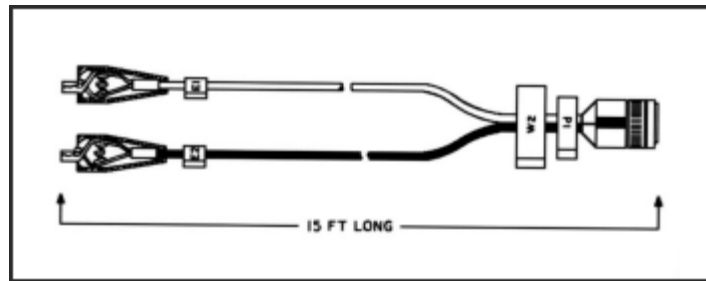
- W1 - DCA cable
- W2 - Test probe cable
- W3 - Ignition adapter cable
- W4 - Transducer cable (two)
- W5 - Power cable



**FIGURE 53. DIAGNOSTIC CONNECTOR ASSEMBLY CABLE W1.**

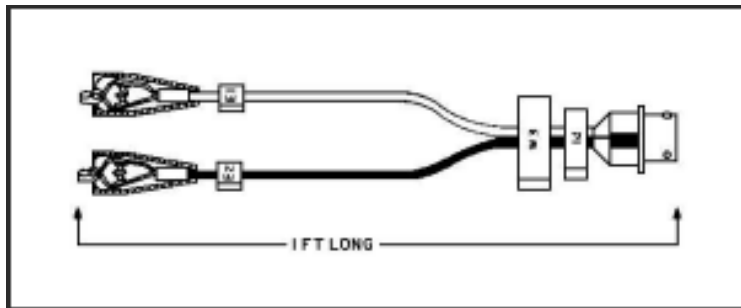
Used to power the VTM and provide access to test points and sensors connected to the vehicle/equipment mounted DCA. When a DCA measurement is being performed, both the power and the measurement information are received through W1.





**FIGURE 54. TEST PROBE CABLE W2.**

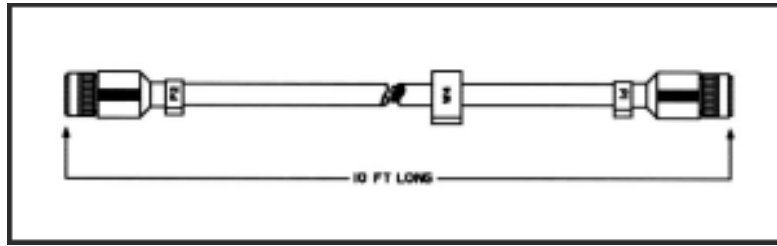
Used for general and special measurements. It is used for measuring voltages, frequency, resistance, and continuity; and also for the first-peak series and compression unbalance tests. W2 is divided into two color coded leads, red for E1 and black for E2. Test clips E1 and E2 of W2 attach to points on the equipment being tested.



**FIGURE 55. IGNITION ADAPTER CABLE W3.**

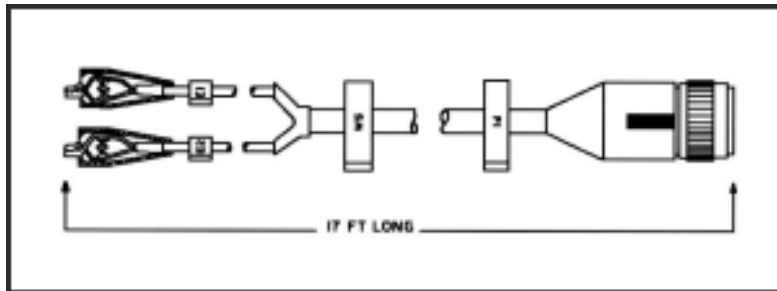
Used in measuring dwell angle, points voltage, engine RPM, and power tests. W3 is divided into two color-coded leads; red for E1 and black for E2.

### Lesson 3/Learning Event 4



**FIGURE 56. TRANSDUCER CABLES W4.**

Used as extensions to connect the VTM to a pressure transducer, pulse tachometer, current probe, or ignition adapter cable. Two transducer cables can be joined using connector adapter, TK item 29.



**FIGURE 57. POWER CABLE W5.**

Used to power the VTM when cable W1 is not being used. Cable W5 is divided into two leads with color-coded clips, red for E1 and black for E2. Battery clips E1 and E2 are attached to a vehicle/equipment battery or a 9- to 32-volt 4A regulated power supply. Never connect the VTM to a battery charger unless it is also connected to a battery, or damage to the VTM may result.

**Transit Case**

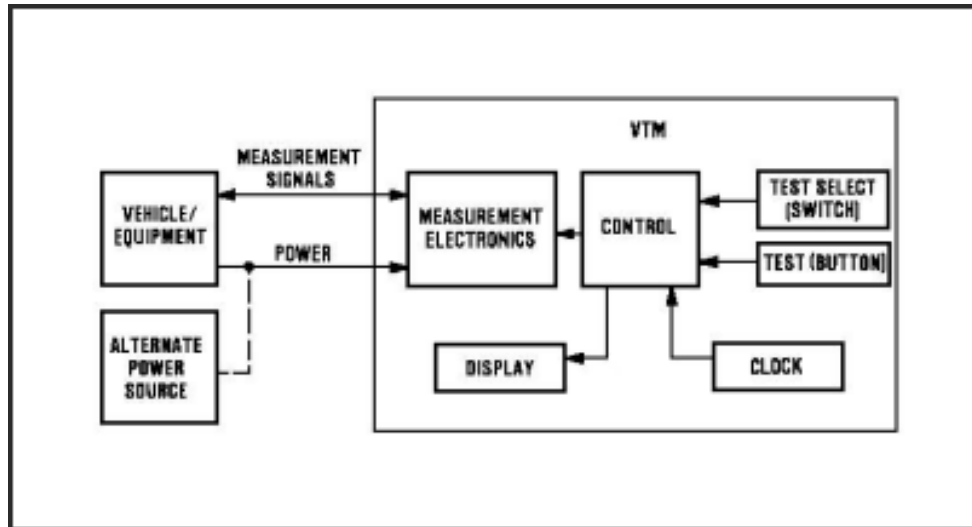
The STE/ICE is housed in a portable, protective transit case which contains all necessary accessories.

A relief valve on the front of the case allows the operator to release pressure or vacuum caused by changes in climate during transit.

## Lesson 3/Learning Event 4

### PRINCIPLES OF OPERATION

This section describes the principles of operation for the STE/ICE VTM, cables, and accessories. Block diagrams show power, control, and display functions.



**FIGURE 58. OPERATIONAL DIAGRAM.**

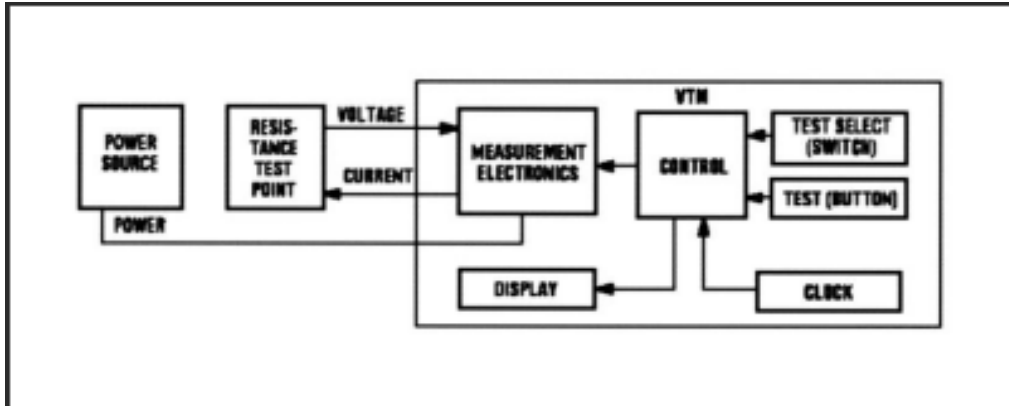
Power is supplied to the VTM from the vehicle/equipment battery or an alternate power source.

Measurement information is sent to the VTM and is compared to values stored in its memory.

Setting the TEST SELECT switches tells the VTM which measurement procedure to do.

Pressing and releasing the TEST button tells the VTM to perform the measurement procedure.

The VTM display shows the results in the unit being measured (volts, RPM, PSI, and so forth) or as a PASS/FAIL message.

Resistance Measurement**FIGURE 59. RESISTANCE.**

Setting the TEST SELECT switches to the required test number tells the VTM to make a resistance measurement when the TEST button is pressed and released.

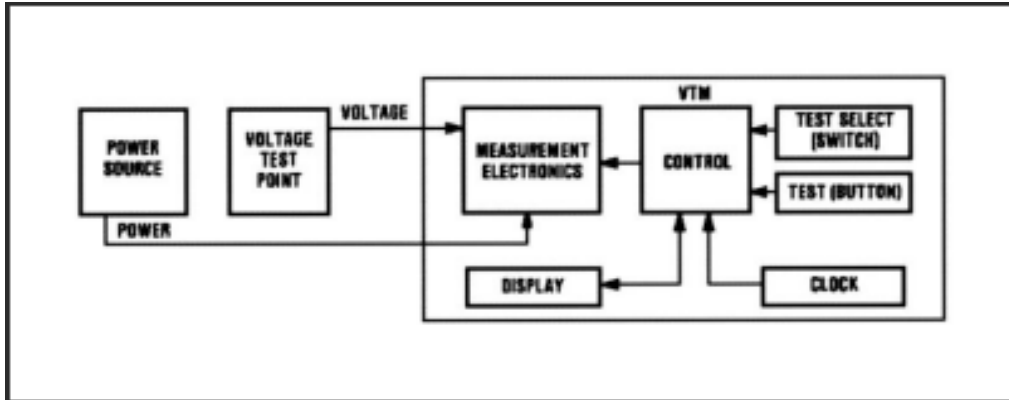
The VTM supplies constant electrical current to the vehicle/equipment under test.

Voltage across equipment under test is measured, and resistance is calculated by the VTM.

The VTM displays the resistance in ohms or kilohms.

## Lesson 3/Learning Event 4

### AC Voltage Measurement

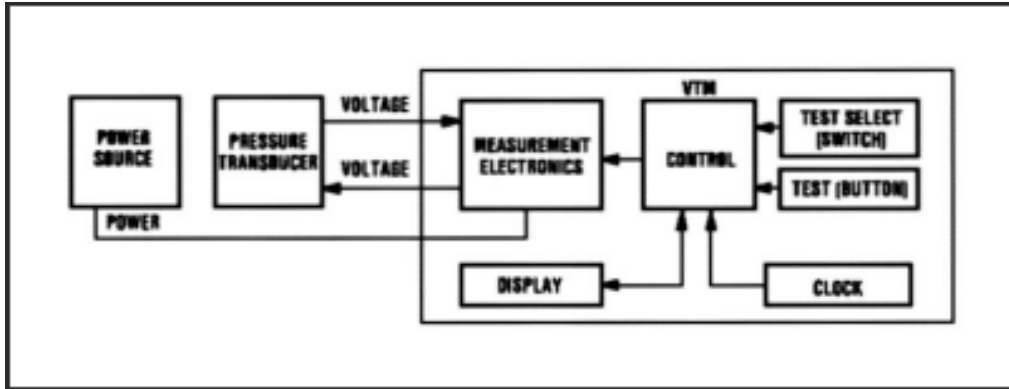


**FIGURE 60. AC VOLTAGE.**

Setting the TEST SELECT switches to the required test number tells the VTM to make the AC voltage measurement when the TEST button is pressed and released.

The AC voltage value across vehicle/equipment under test is sent to the VTM.

The VTM displays the average value of the signal in volts.

Pressure Measurement**FIGURE 61. PRESSURE.**

Setting the TEST SELECT switches to the required test number tells the VTM to make a pressure measurement when the TEST button is pressed and released.

VTM supplies constant voltage to the pressure transducer.

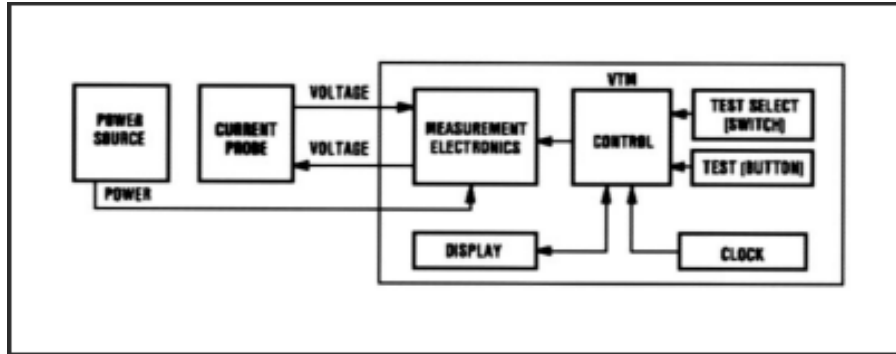
The pressure transducer returns a voltage in proportion to the pressure being measured.

Voltage developed by the transducer is measured and converted to pressure by the VTM.

The VTM displays the pressure in PSIG, inches of mercury, or inches of water.

## Lesson 3/Learning Event 4

### Current Measurement



**FIGURE 62. CURRENT.**

Setting the TEST SELECT switches to the required test number tells the VTM to make a current measurement when the TEST button is pressed and released.

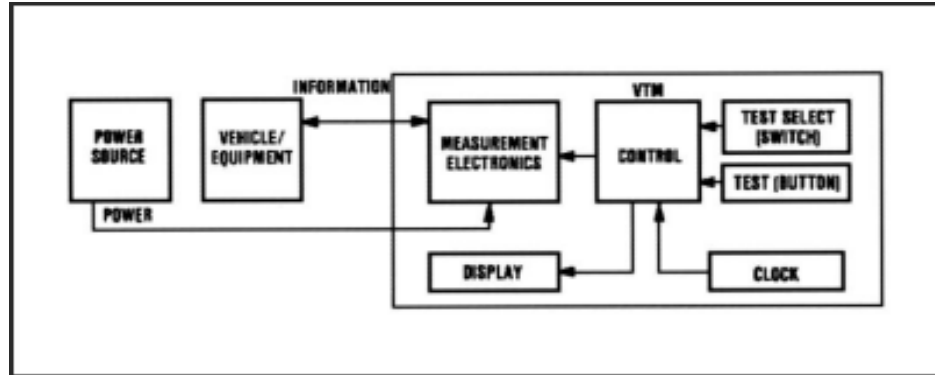
VTM supplies constant voltage to the current probe.

The current probe returns a voltage in proportion to the current being measured.

Voltage developed by the current probe is measured and converted to current by the VTM.

The VTM displays the current in amps.



**RPM Measurement****FIGURE 63. RPM.**

Setting the TEST SELECT switches to the required test number tells the VTM to make an RPM measurement when the TEST button is pressed and released.

On CI engines, the VTM measures the time needed for an engine revolution.

On SI engines, the VTM measures the time between cylinder firings.

The VTM uses an internal clock as a time reference to convert these measurements to RPM.

The VTM displays the engine speed in RPM.

OPERATOR'S CONTROLS AND INDICATORS

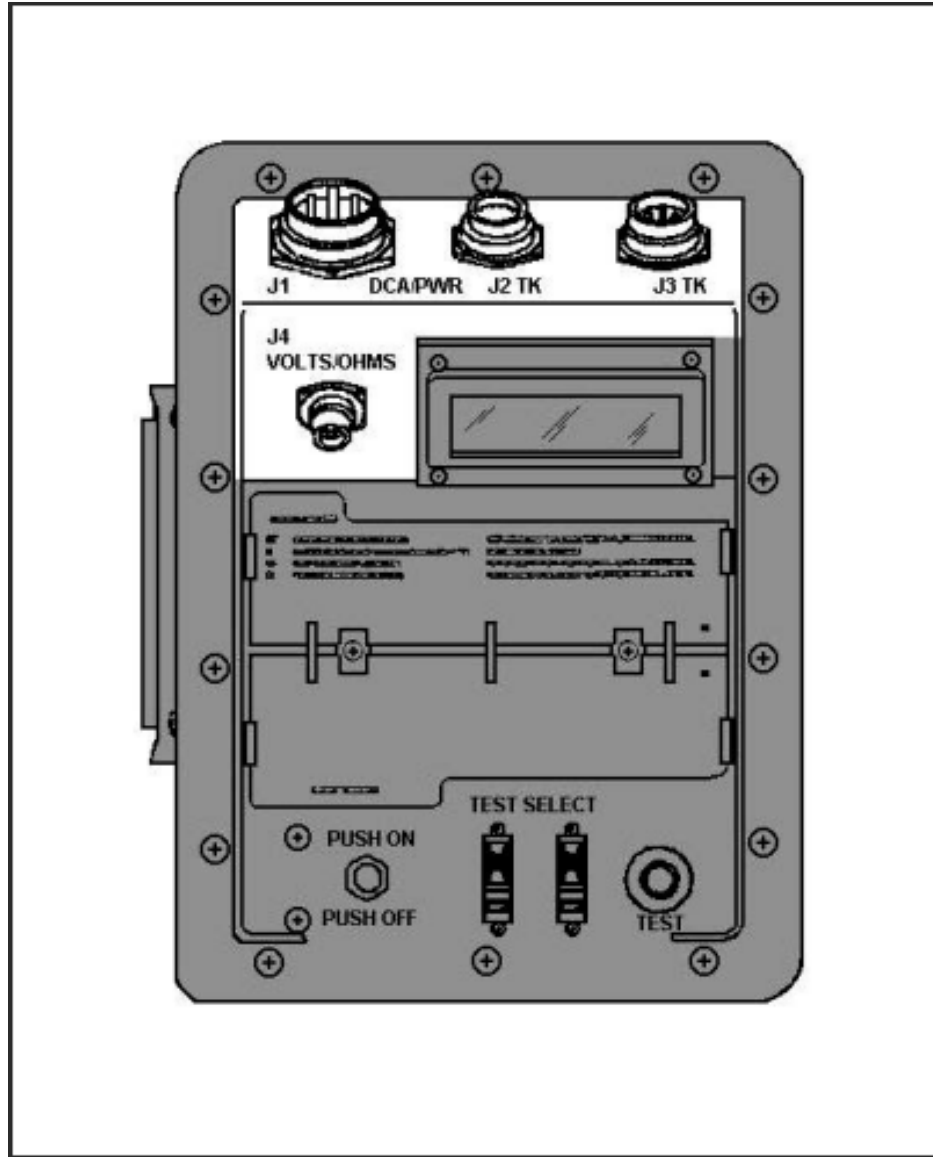


FIGURE 64. CONNECTORS.

**DCA/Power Connector J1**

Used to connect VTM to either a vehicle diagnostic connector with the DCA cable W1 or to a DC power source with the power cable W5. The DC power source is usually the vehicle batteries.

**Transducer Cable Connectors J2 TK and J3 TK**

Used to connect transducer cables W4 to VTM when doing TK measurements. Power and signals are routed through these connectors. Both connectors may be used if a test requires two measurements to be made at the same time.

**Volts/Ohms Connector J4**

Used to connect test probe cable W2 to VTM for voltage and resistance tests.

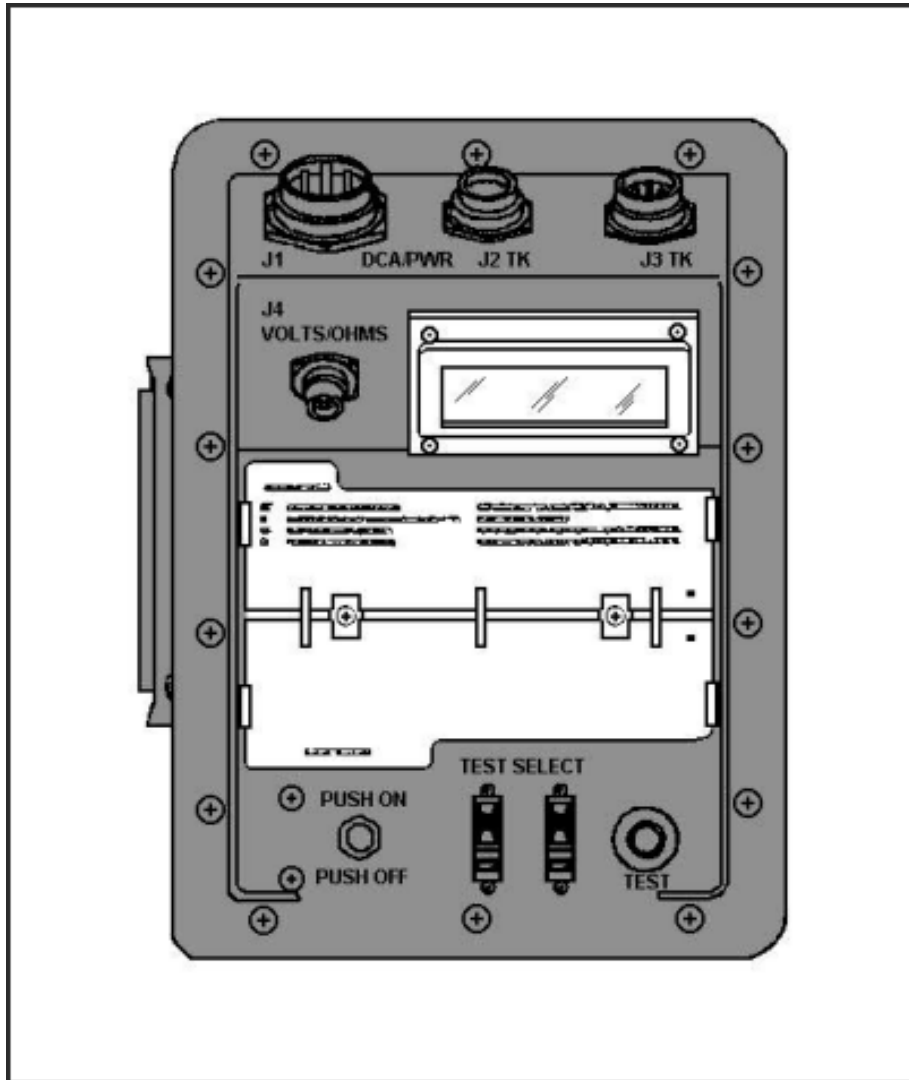


FIGURE 65. READOUT AND FLIP CARDS.

**Readout Display**

Displays different types of readouts during testing up to a maximum of four characters. Types of readouts are:

Status - keeps operator informed of what is happening, such as power applied, failed test, and so forth.

Numerical - measurement results. Units of measurement (PSI, RPM, volts, and so forth) are not displayed.

Error - informs operator of an error (wrong test number entered, transducer not connected, VTM faulty, and so forth).

**Flip Cards**

General information to aid in testing.

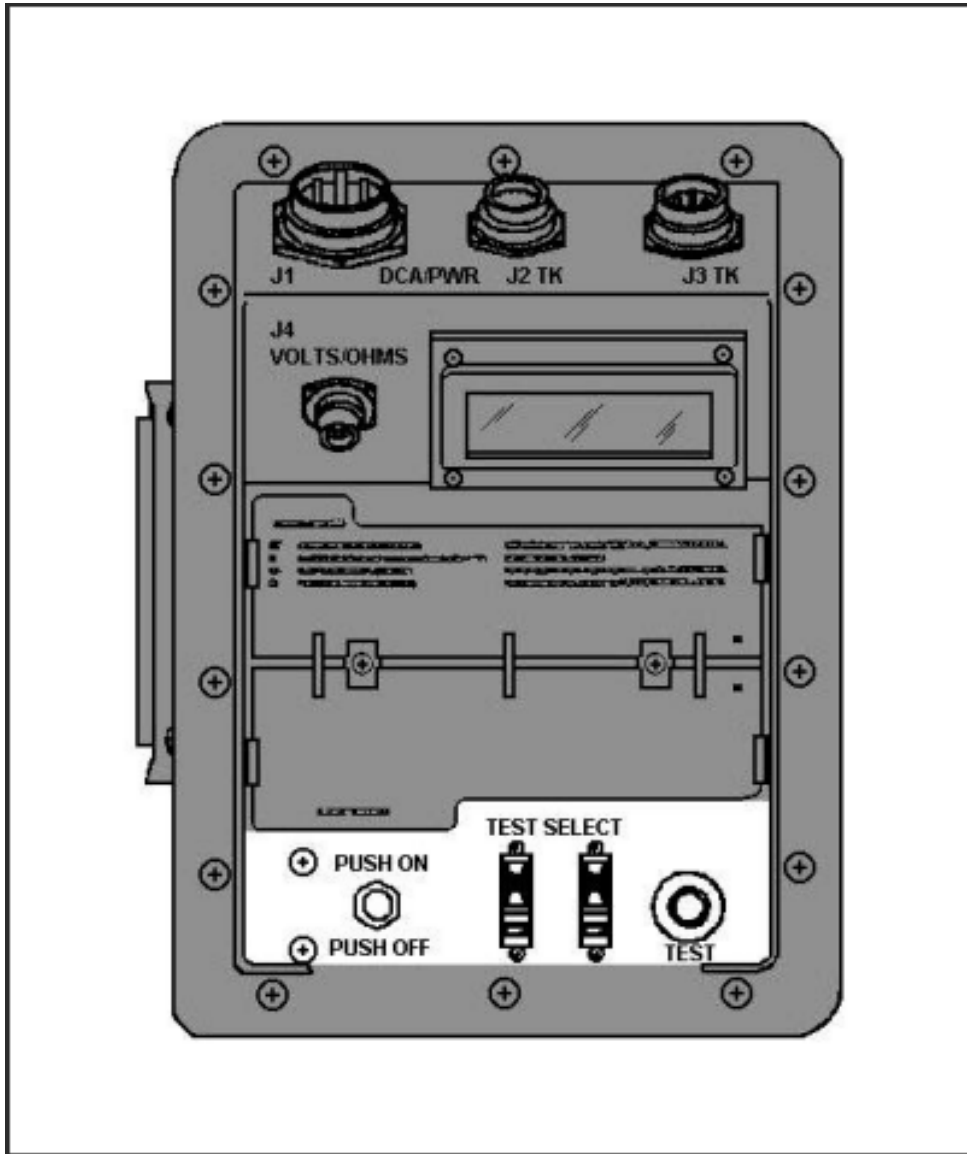


FIGURE 66. SWITCHES.

**Test Button**

This push-button switch has two functions:

Press and Release - causes selected test measurement to begin.

Press and Hold - initiates an offset test.

**Test Select Switches**

Two 10-position switches. Used to select the test to be performed by the VTM when the TEST button is pressed and released.

**Push On/Pull Off Switch**

Used to control power to the VTM from the power source. Switch contains a 4-ampere circuit breaker to protect VTM internal circuitry.

## Lesson 3/Learning Event 4

### ERROR MESSAGES

An error message indicates that the VTM needs additional or corrected information before testing can continue, or that additional procedures are required.

Error messages are displayed as an E followed by three numbers (for example, E003).

#### Error Message Displays

DISPLAY	MEANING
E000	VTM has been asked for information that it does not have. (For example, you have requested the vehicle/equipment ID and it has not been entered.)
E001	A test number which does not exist has been entered on the TEST SELECT switches.
E002	The required transducer is not connected.
E003	Test number wrong for DCA connected. This happens if the test selected does not apply to the class of vehicle/equipment under test, or if the DCA harness does not have the required transducers.
E004	A vehicle identification (VID) number or number-of-cylinders information has not been entered. It can also occur if a VID has been entered that the VTM has not been programmed to recognize.
E005	Required offset test was not performed.
E007	The VID number and number-of-cylinders information do not agree.
E008	VTM is not receiving required voltage signal for selected test. This message can occur on tests 14, 15, 19, 20, and 72 through 79.
E009	VTM is not receiving engine speed signal. This applies only to engine power test and SI full power simulation.



DISPLAY	MEANING
E010	A wrong VID number was entered. The VTM will only accept numbers between 01 and 28. If E010 is displayed when the VID entered was between 01 and 28, it means that the VID does not agree with the identity of DCA harness powering the VTM. Testing may continue.
E011	Throttle control was operated incorrectly. It took too long to accelerate or decelerate during power test.
E012	The SI ignition adapter, TK item 30, or CI pulse tachometer, TK item 34, is missing or not connected to the VTM.
E013	VTM unable to use data received.
E014	The wrong number of cylinders was entered.
E015	The number-of-cylinders information entered does not agree with the number of cylinders in the vehicle powering VTM (DCA harness).
E017	VTM not receiving ignition information.
E018	Test discontinued due to no information being detected by VTM. This will occur after several minutes of no-signal operation.

## Lesson 3/Learning Event 4

### STATUS MESSAGES

A status message keeps the operator informed of what is happening. The status messages and their meanings are as follows:

#### Status Message Displays

DISPLAY	MEANING
.8.8.8.8	There is power to the VTM, and the display is working properly. This appears only for a short period after power is turned on.
----	After power turn-on, VTM is ready for testing. During compression unbalance test, testing is in progress.
.9.9.9.9	VTM is reading a test value beyond its range.
PASS	Unit under test has passed test, or VTM has accepted a control function entry.
FAIL	Unit under test has failed test.
AUE	Numerical display is an average value.
LO	Engine speed below 1,600 RPM during SI power test. Indicates the engine failed the power test.
-1-1-1-1	VTM is busy.

**PROMPTING MESSAGES**

A prompting message means that the operator must do something. After the operator action, testing will continue. The prompting messages and their meanings are as follows:

**Prompting Message Displays**

<b>DISPLAY</b>	<b>MEANING</b>
UEH	Tells the operator to enter VID on the TEST SELECT switches.
CYL	Tells the operator to enter the number of cylinders into the VTM.
GO	Tells the operator to crank the engine.
SIP	Tells the operator to apply full throttle in an SI power test.
CIP	Tells the operator to apply full throttle in a CI power test.
OFF	Tells the operator to stop the operation being performed. In a compression unbalance test, this means stop cranking the engine. In a CI power test, it means to release the accelerator.
CAL	Tells the operator to release the TEST button during an offset test.
0066	Tells the operator to set TEST SELECT switch to 99 during confidence test.

**Confidence Test Error Messages**

Confidence test messages are displayed either as PASS or by a C followed by three numbers (#). A C### is an error message used by VTM repair personnel.

## Lesson 3

### PRACTICE EXERCISE

1. How is a voltmeter connected into a circuit?
  - a. Series
  - b. Parallel
  - c. Series-parallel
  
2. Which meter is equipped with its own battery?
  - a. Voltmeter
  - b. Ammeter
  - c. Ohmmeter
  
3. Which test can be made with the multimeter that can also be made with the LVCT?
  - a. AC voltage
  - b. DC voltage
  - c. Resistance
  
4. The STE/ICE VTM can receive its power from
  - a. any 12- or 24-volt power supply.
  - b. its own internal batteries.
  - c. any power generator.
  
5. STE/ICE can be used to test
  - a. electrical components only.
  - b. vehicle engines only.
  - c. electrical and mechanical components.

## Lesson 3

**This page intentionally left blank.**

### **Lesson 3**

#### **ANSWERS TO PRACTICE EXERCISE**

1. b (page 66)
2. c (page 75)
3. b (page 84)
4. a (page 88)
5. c (page 88)